

P	LTR	DESCRIPTION	DATE	DWN	APVD
	A2	REVISED PER ECR-17-000724	18JAN2017	HG	TD

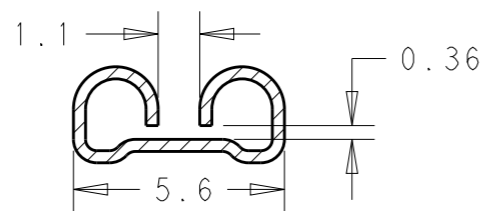

SECTION Q-Q

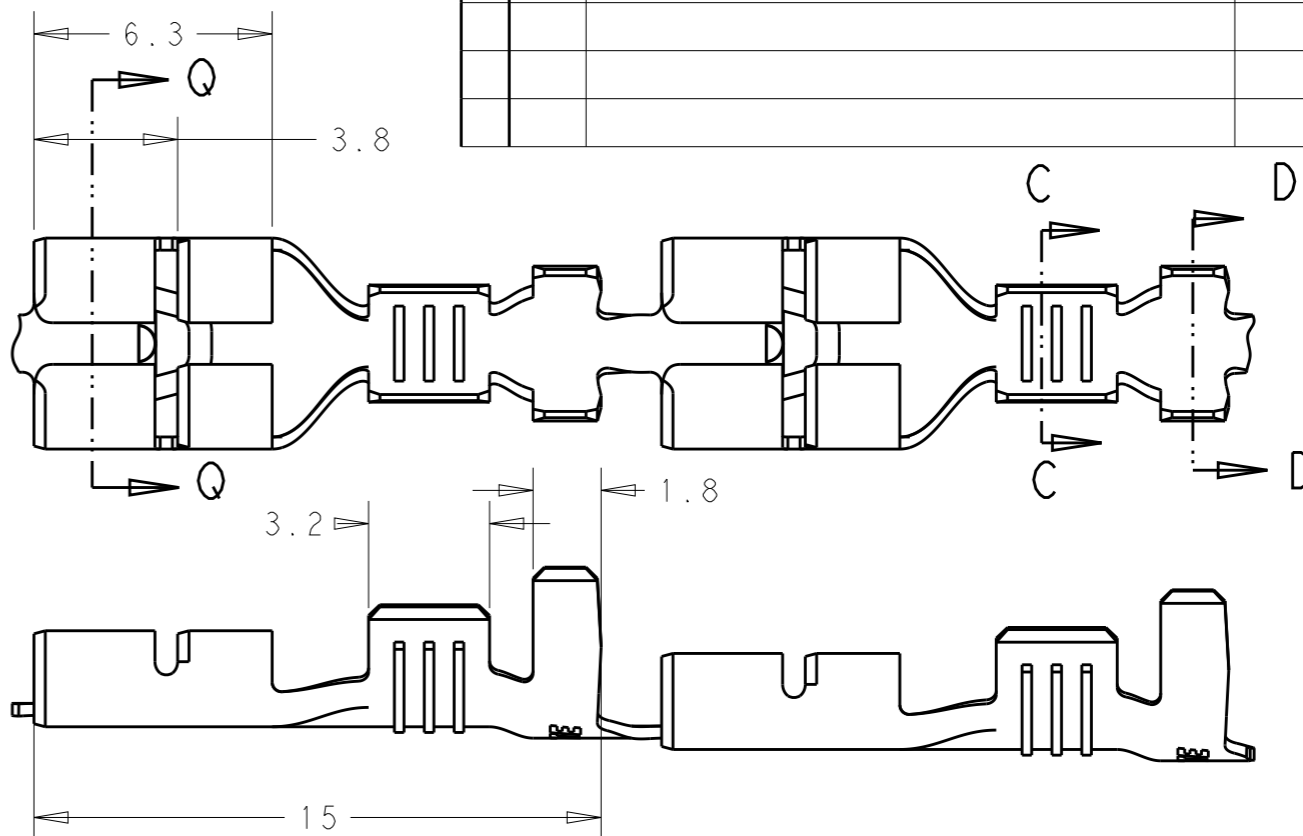
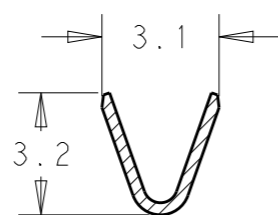

SECTION C-C

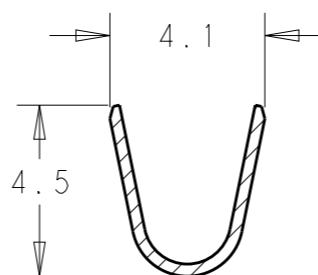

SECTION D-D

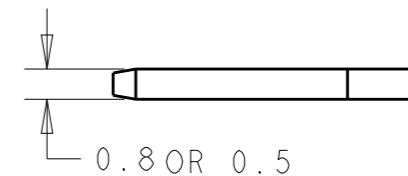
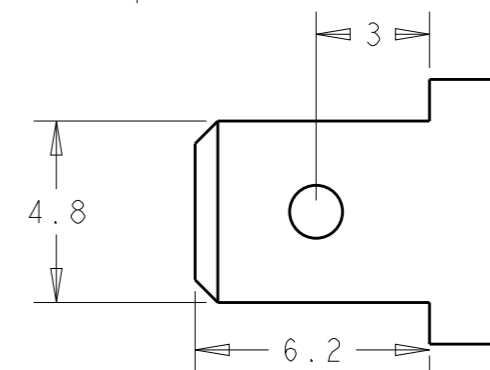

RECOMMENDED MATING TAB DIMENSION

- 1) CONTINUOUS STRIP ON REELS .
- 2) WIRE SIZE: 0.5mm²-1.5mm²; INSULATION RANGE 2.3-3.3MM.
- 3) MATING TAB THK .0.50+0.04/-0.03 or 0.80+0.04/-0.03.
- 4) APPLICATION REMARK: THIS TERMINAL CAN BE USED ON COUNTERPART TABS HAVING THICKNESS 0.5MM AND 0.8MM. IT IS NOT ALLOWED TO MATE WITH THE 0.5MM TAB AFTER MATE WITH THE 0.8MM TAB.

TIN PLATE	BRASS	2293255-1
FINISH	MATERIAL	PART NO

THIS DRAWING IS A CONTROLLED DOCUMENT.		DWN 10SEP2015 JASON JIANG	STE TE Connectivity	
DIMENSIONS: mm		CHK TIM DING		
TOLERANCES UNLESS OTHERWISE SPECIFIED:		APVD TIM DING	NAME 4.8mm FASTON REC. CTC FOR THK TABS 0.5mm AND 0.8mm	
0 PLC ±0.5		PRODUCT SPEC 108-106242	SIZE A3	
1 PLC ±0.2		APPLICATION SPEC 114-106242	CAGE CODE -	DRAWING NO C-2293255
2 PLC ±0.10		WEIGHT -	RESTRICTED TO -	
3 PLC ±		CUSTOMER DRAWING	SCALE N/A	SHEET 1 OF 1
4 PLC ±			REV A2	
ANGLES ±				
FINISH				
MATERIAL SEE TABLE				