

Apr.1.2017 Copyright 2017 HIROSE ELECTRIC CO., LTD. All Rights Reserved.

COUNT	DESCRIPTION OF REVISIONS	BY	CHKD	DATE	COUNT	DESCRIPTION OF REVISIONS	BY	CHKD	DATE

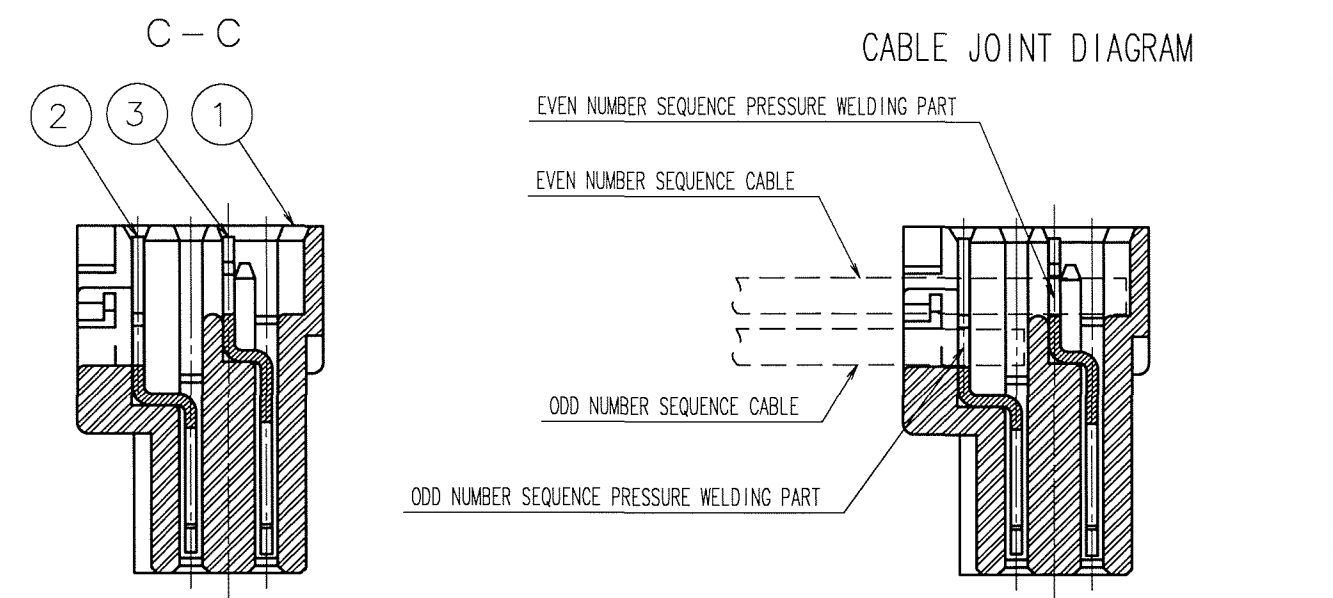
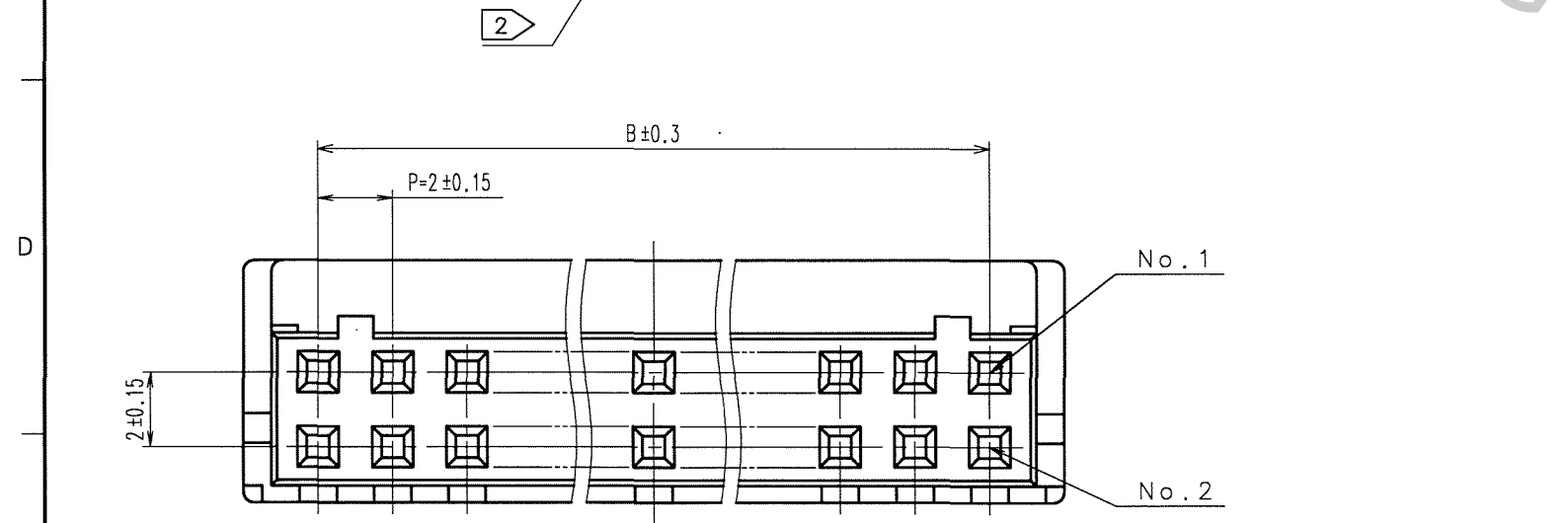
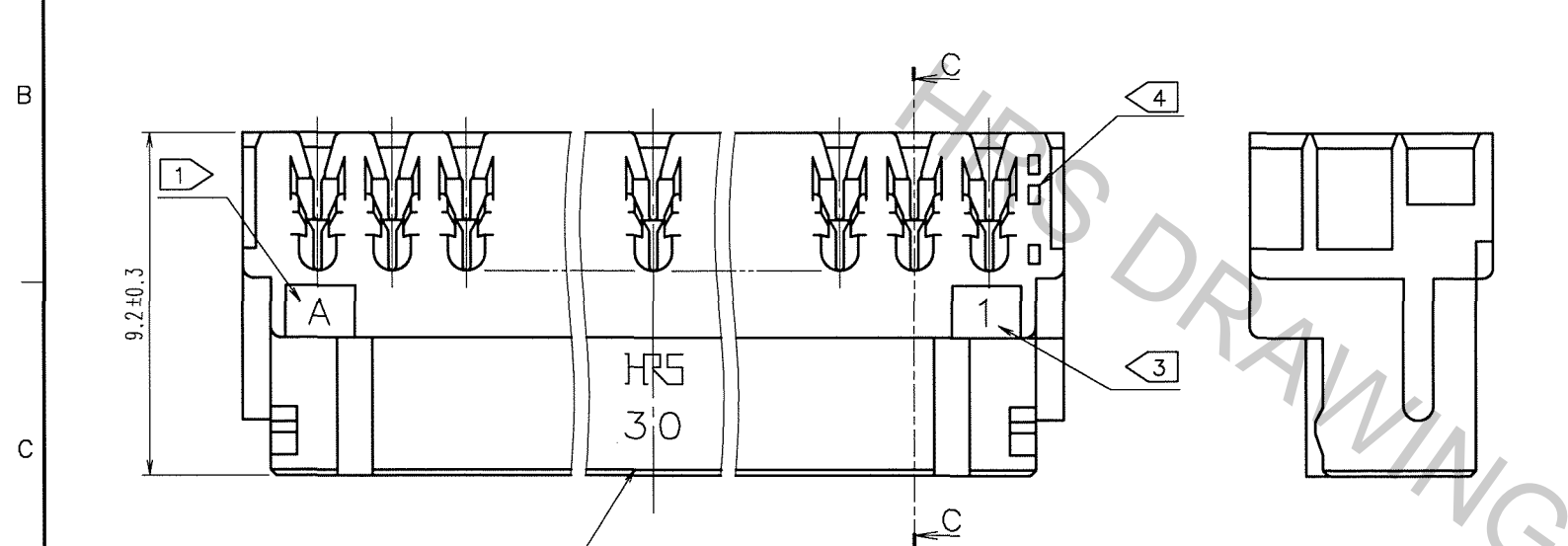
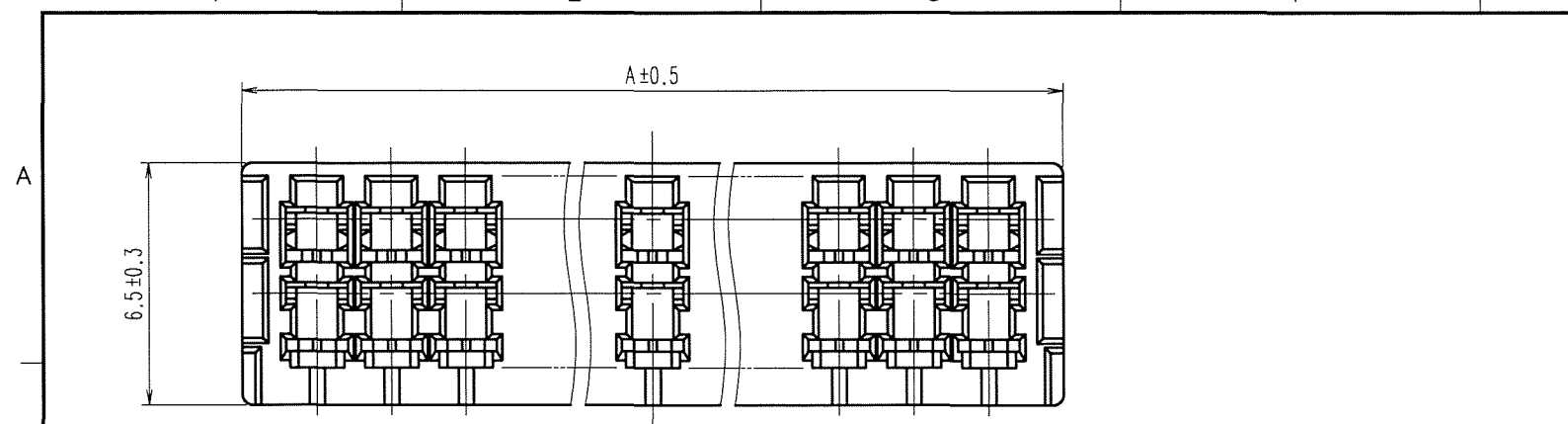

HRS NO.	PART NO.	A	B
CL543-0652-0-05	DF11- 4DS-2R26(05)	6	2
CL543-0653-3-05	DF11- 6DS-2R26(05)	8	4
CL543-0654-6-05	DF11- 8DS-2R26(05)	10	6
CL543-0655-9-05	DF11-10DS-2R26(05)	12	8
CL543-0656-1-05	DF11-12DS-2R26(05)	14	10
CL543-0657-4-05	DF11-14DS-2R26(05)	16	12
CL543-0658-7-05	DF11-16DS-2R26(05)	18	14
CL543-0659-0-05	DF11-18DS-2R26(05)	20	16
CL543-0660-9-05	DF11-20DS-2R26(05)	22	18
CL543-0661-1-05	DF11-22DS-2R26(05)	24	20
CL543-0662-4-05	DF11-24DS-2R26(05)	26	22
CL543-0663-7-05	DF11-26DS-2R26(05)	28	24
CL543-0664-0-05	DF11-28DS-2R26(05)	30	26
CL543-0665-2-05	DF11-30DS-2R26(05)	32	28
CL543-0666-5-05	DF11-32DS-2R26(05)	34	30

- NOTES
- 1 DIE CAVITY No.
 - 2 NUMBER OF CONTACT.
 - 3 AT CONTACT No.1 SIDE.
 - 4 ONE SQUARE HOLE IN LOW ROW MEANS ODD NUMBER SIDE AND TWO SQUARER HOLES IN UPPER LOW EVEN NUMBER OF CONTACT No. RESPECTIVELY.

SUFFIX	WIRE	WIRE CONSTRUCTION	OUTER DIAMETER OF INSULATION
R26	UL1061 AWG26	7/0.16	0.95 TO 1.05

2	PHOSPHOR BRONZE	SURFACE:TIN PLATED 1μm min UNDER PLATING:NICKEL PLATED 0.5μm min	3	PHOSPHOR BRONZE	SURFACE:TIN PLATED 1μm min UNDER PLATING:NICKEL PLATED 0.5μm min
1	POLYAMIDE	UL94V-0, BLACK			
NO.	MATERIAL	FINISH, REMARKS	NO.	MATERIAL	FINISH, REMARKS

CODE NO. (OLD)	DRAWN	DESIGNED	CHECKED	APPROVED	RELEASED
	A.Miura	N. Hirose	H. Umehara	J. Omi	
	'06.02.22	'06.03.08	'06.03.10	'06.03.14	

SCALE	DRAWING NO.	PART NO.
5 : 1	EDC3-071615-01	DF11-*DS-2R26(05)
UNITS	HRS HIROSE ELECTRIC CO., LTD	CODE NO.
mm		CL543

TO