

DRAWING MADE IN THIRD ANGLE PROJECTION
 THIS DRAWING IS UNPUBLISHED. RELEASED FOR PUBLICATION
 © COPYRIGHT 19 BY AMP INCORPORATED, HARRISBURG, PA. ALL INTERNATIONAL RIGHTS RESERVED. AMP PRODUCTS MAY BE COVERED BY U.S. AND FOREIGN PATENTS AND/OR PATENTS PENDING.

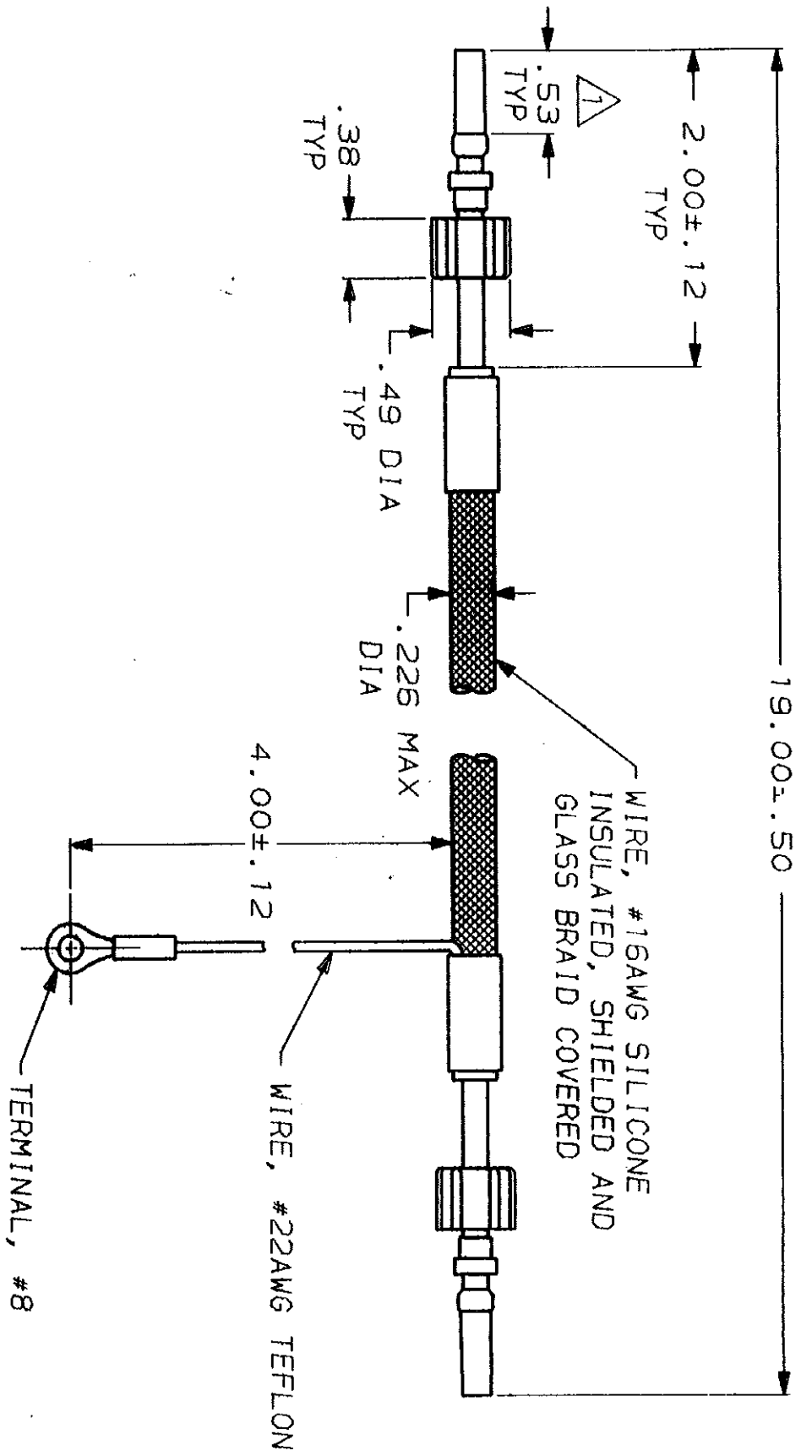

1 TO MATE WITH AMP LGH-1/2 RECEPTACLE WITH .53 BARREL DEPTH.
 2. MARKED PER MIL-STD-130.

LOC	DIST	P	F	ZONE	LTR	DESCRIPTION	DATE	APPROVED
L	37		✓		A	REV & REDRAWN ECN 53475	8-27-85	M.J.

UNLESS OTHERWISE SPECIFIED DIMENSIONS ARE IN INCHES TOLERANCES ON:		DR	R. HEPPNER	8-15-85	AMP INCORPORATED Harrisburg, Pa. 17105			
2 PL DEC ± .02	3 PL DEC ± .02	CHK	-		LEAD ASSY, LGH-1/2			
ANGLES ±		APPD	M. GARDNER	8-19-85	NAME			
		APPD	-		SIZE	FSCM NO	DRAWING NO	PART NO
		PRODUCT SPEC	-		C	00779	868582	868582-1
		APPLICATION SPEC	-		SCALE	1:1	SHEET	1 OF 1
		WEIGHT	-		CUSTOMER DRAWING			

AMP 1471-7 REV 10-84