

| ATLANTIC VERSION TERMINATOR INTERFACE ADAPTER | PART NUMBER | REVISION | DESCRIPTION | FEED TYPE | APPLICATOR STYLE CONVERSION CHART | | | | | | |
|---|-------------|--------------------------|--------------------------|-------------------|-----------------------------------|-----------------------|-----------|-------------|-----------|-----------|------------------------|
| | | | | | CONVERT TO | PART NUMBERS REQUIRED | | | | | |
| | 2266814-1 | A | FINE CRIMP HEIGHT ADJUST | MECHANICAL | PNEUMATIC FEED | 2119950-1 | 1338685-1 | 5-18022-5 | 2119641-1 | 2119799-1 | 2063440-1 |
| | 2266814-2 | A | FINE CRIMP HEIGHT ADJUST | PNEUMATIC | SERVO LATCH PLATE | 2119951-1 | - | 8-2266814-5 | 1901094-3 | - | 2168400-6 (QUANTITY 2) |
| | | | | | SMART APPLICATOR | 2161326-1 | - | 8-2266814-4 | - | - | |
| | | | | | MECHANICAL FEED | 2119949-1 | 1338685-1 | 5-18022-5 | 2119653-1 | - | - |
| | 2266814-5 | A | FINE CRIMP HEIGHT ADJUST | SERVO LATCH PLATE | SERVO LATCH PLATE | 2119951-1 | - | 8-2266814-5 | 1901094-3 | - | 2168400-6 (QUANTITY 2) |
| | | | | | SMART APPLICATOR | 2161326-1 | - | 8-2266814-4 | - | - | |
| | 2266814-6 | A | NON-CRIMP HEIGHT ADJUST | SERVO LATCH PLATE | MECHANICAL FEED | 2119949-1 | 1338685-1 | 5-18022-5 | 2119653-1 | - | - |
| PNEUMATIC FEED | | | | | 2119950-1 | 1338685-1 | 5-18022-5 | 2119641-1 | 2119799-1 | 2063440-1 | |
| 2266814-7 | A | FINE CRIMP HEIGHT ADJUST | NONE | - | - | - | - | - | - | - | |
| 7-2266814-7 | A | CRIMP TOOLING KIT | - | - | - | - | - | - | - | - | |

| APPLICATOR DATA | | |
|-----------------|----------------|------|
| CRIMP | SIZE | TYPE |
| WIRE | 1.47 mm [.058] | F |
| INSUL | 1.65 mm [.065] | F |

APPLICATOR INSTRUCTIONS
408-10389

| TERMINAL DATA: JST TERMINAL | | JST CRIMP SPECIFICATION | |
|---|----------------|---|-----------------|
| TERMINAL NAME: TERMINAL | | | |
| WIRE STRIP LENGTH 2.30-3.10 mm [.091-.122 IN] | | INSULATION DIAMETER RANGE Ø1.20-1.80 mm [.047-.071 IN] | |
| TERMINAL APPLICATION SPECIFICATION H4009/017-00 Rev 01-29-01 | | | |
| TERMINALS APPLIED | | | |
| TE TERMINAL | JST TERMINAL | TE TERMINAL | JST TERMINAL |
| 286860-1 | SHF-001T-0.8BS | 286860-4 | SHF-001-0.8BS |
| 286860-2 | SHF-001T-0.8SS | 286860-5 | SHF-001G1-0.8BS |
| 286860-3 | SHF-001-0.8SS | | |

| WIRE SIZE | CRIMP HEIGHT mm [INCH] | CRIMP HEIGHT REFERENCE SETTING |
|-----------|--------------------------------|--------------------------------|
| 22 AWG | 0.80 +/- 0.05 [.031 +/- .002] | 5.1 |
| 24 AWG | 0.75 +/- 0.05 [.030 +/- .002] | 5.6 |
| 26 AWG | 0.70 +/- 0.05 [.028 +/- .002] | 6.2 |
| 28 AWG | 0.68 +/- 0.025 [.027 +/- .001] | 6.4 |

- 1. RECOMMENDED SPARE PARTS
- 2. GREASE BEARING SURFACES LIGHTLY
- 3. LUBRICATE DAILY PER THE APPLICATOR INSTRUCTION SHEET SUPPLIED WITH THE APPLICATOR.
- 4. APPLICATOR SPECIFIC DATA TO BE ENTERED INTO BLANK MEMORY CHIP AT ASSEMBLY. SEE BELOW FOR PART NUMBER:
 MECHANICAL FEED WITH "SMART APPLICATOR" CONVERSION: 8-2266814-4
 PNEUMATIC FEED WITH "SMART APPLICATOR" CONVERSION: 8-2266814-4
 SERVO FEED WITH "FINE CRIMP HEIGHT ADJUST": 8-2266814-5
 SERVO FEED WITH "NON-CRIMP HEIGHT ADJUST": 8-2266814-6
- 5. ADJUSTMENT OF THE STRIPPER MAY BE REQUIRED WHEN MOVING THE APPLICATOR BETWEEN BENCH AND LEADMAKER APPLICATIONS.
- 6. APPLY PART NUMBER 1-23419-5 LOCTITE TO THREADS OF ITEM 62. APPLY PART NUMBER 2-23419-6 LOCTITE TO THREADS OF ITEM 242. FOR -6 ONLY APPLY PART NUMBER 1-23419-5 LOCTITE TO THREADS OF ITEM 37.
- 7. GREASE THREADS, GROOVE AND O-RING ON ITEMS 35 & 252.
- 8. MAGNET, ITEM 166 MUST BE ORIENTED CORRECTLY IN ORDER TO PROPERLY ACTUATE THE COUNTER.
- 9. CRIMP HEIGHT REFERENCE SETTING WAS THE SETTING USED WHEN THE APPLICATOR WAS QUALIFIED AT THE FACTORY. ADJUSTMENT MAY BE NECESSARY WHEN RUNNING APPLICATOR IN THE FIELD.
- 10. SPARE FEED CAM STORAGE LOCATION REFER TO INSTRUCTION SHEET FOR ADDITIONAL INFORMATION.
- 11. TO CONVERT THE APPLICATOR TO A NON-CARRIER CUTTING STYLE, REMOVE ITEM 13 AND ATTACH TO THE LOCATION ON THE BACK SIDE OF THE HOUSING. REFER TO INSTRUCTION SHEET FOR ADDITIONAL INFORMATION.
- 12. WHEN ASSEMBLING A NON CRIMP HEIGHT ADJUST APPLICATOR (-6) USE SHIMS FROM ITEM 260 TO ACHIEVE A NOMINAL SHIM HEIGHT OF 5.00.

***WARNING**
 ON INSTALLATION, SET WIRE DISC, ITEM 40 TO LARGEST WIRE SIZE SETTING. USE OF SETTINGS BELOW MINIMUM REQUIRED CRIMP HEIGHT SETTING WILL CAUSE DAMAGE TO CRIMP TOOLING.

ATLANTIC VERSION
 Shown on sheets 1 of 4 & 2 of 4
 (Pacific version shown on sheets 3 of 4 & 4 of 4)

| SET UP GAUGE | LOC | DIST | REVISIONS | | | |
|--------------|-----|------|-----------|----------|-----------|-------|
| 2119599-1 | A | 66 | # | DATE | OWN | APVD |
| | | | A | RELEASED | 11AUG2015 | GH GB |

| | | | | | | | | |
|---|-----|-----|-----|-----|-----|-------------|-------------------------------------|-----|
| - | - | 1 | - | - | - | 2119957-2 | APPLICATOR SHIM PACK | 260 |
| - | 1 | - | 1 | 1 | 1 | 8-21084-0 | O-RING, .676 ID, .070 DIA. MAT. | 252 |
| - | - | - | - | 1 | - | 2119640-1 | PUSH ROD, AIR FEED | 250 |
| - | - | - | - | 1 | - | 2079988-1 | BUSHING, LCH5-12, MISUMI | 249 |
| - | - | - | - | 1 | - | 2119641-1 | FEED CAM, AIR FEED | 248 |
| - | 1 | - | 1 | 1 | 1 | 2119798-1 | DETENT PIN | 247 |
| - | 1 | - | 1 | 1 | 1 | 1-22279-3 | SPRING, COMPRESSION | 246 |
| - | - | 1 | - | - | - | 2119758-1 | RAM, AMP STYLE, SIDE FEED, NON-ADJ. | 245 |
| - | 1 | 1 | 1 | 1 | 1 | 2119082-4 | CAM, SNAIL, INSULATION ADJUSTMENT | 244 |
| - | 1 | 1 | 1 | 1 | 1 | 2079764-1 | WASHER, WAVE SPRING, CREST-TO-CREST | 243 |
| - | 1 | 1 | 1 | 1 | 1 | 2119083-1 | RETAINER, INSULATION DIAL | 242 |
| - | 1 | 1 | 1 | 1 | 1 | 7-18023-7 | SCR, SKT HD CAP M3 X 4.0 | 241 |
| - | - | 2 | 2 | - | - | 2168400-6 | SHCS, LOW HEAD, RoHS, M5 X 16 | 240 |
| - | - | - | - | - | 1 | 2119580-1 | MECHANICAL FEED ASSEMBLY | 239 |
| - | - | - | - | 1 | - | 2063440-1 | AIR FEED MODULE | 238 |
| - | - | 1 | 1 | - | - | 2119740-2 | TAG, IDENTIFICATION | 213 |
| - | - | 1 | 1 | - | - | 1901094-3 | SPACER, FEEDER | 198 |
| - | - | - | - | 2 | - | 21045-3 | RING, RETAIN, EXTERN, 3/16 CRESCENT | 172 |
| - | 1 | 1 | 1 | 1 | 1 | 994969-1 | MAGNET, RARE EARTH HIGH ENERGY | 166 |
| - | REF | REF | REF | REF | REF | 994970-2 | COUNTER, MAGNETIC | 164 |
| - | - | - | - | 1 | - | 240638-1 | SPRING, FEED FINGER | 163 |
| - | - | - | - | 1 | - | 3-23627-7 | PIN, RETAIN, GRVD, 3/16 X .854 | 137 |
| - | - | - | - | 1 | - | 2119799-1 | HOLDER, FEED FINGER, AF | 136 |
| - | - | REF | REF | - | - | SEE NOTE 4 | MEMORY CHIP, PROGRAMMED | 135 |
| - | - | 1 | 1 | - | - | 1633743-1 | SERVO FEED LATCH ASM | 133 |
| - | - | REF | REF | - | - | 2119944-1 | FEED FINGER ASSEMBLY, SF | 117 |
| - | 1 | 1 | 1 | 1 | 1 | 455888-5 | SPACER, CRIMPER | 82 |
| - | 1 | 1 | 1 | 1 | 1 | 2119956-1 | DOCUMENTATION PACKAGE | 71 |
| - | 1 | 1 | 1 | 1 | 1 | 2119791-5 | DEPRESSOR, WIRE | 70 |
| - | 1 | - | - | 1 | 1 | 2119740-1 | TAG, IDENTIFICATION | 67 |
| - | 2 | 2 | 2 | 2 | 2 | 2168078-1 | SCREW, DRIVE, RH, RoHS, 2 x .188 | 66 |
| - | 1 | - | 1 | 1 | 1 | 2119793-1 | LIMITER, ADJUSTMENT BOLT | 63 |
| - | 3 | - | 3 | 3 | 3 | 992763-5 | SCR, SET, SOC, CONE POINT, M3 x 4.0 | 62 |
| - | 1 | 1 | 1 | 1 | 1 | 2079383-4 | SCR, BHSC, RoHS (M4 X 8) | 60 |
| - | - | - | - | 1 | 1 | 5-18022-5 | SCR, HEX HD CAP, M4 X 6.0 | 59 |
| - | - | - | - | 1 | 1 | 1338685-1 | PAWL, FEED | 56 |
| - | 4 | 4 | 4 | 4 | 4 | 2168400-1 | SHCS, LOW HEAD, RoHS, M4 X 12 | 54 |
| - | - | - | - | 1 | 2 | 18023-9 | SCR, SKT HD CAP M4 X 6.0 | 49 |
| - | - | - | - | - | 1 | 2119652-1 | FEED CAM, PRE FEED | 48 |
| - | - | - | - | - | 1 | 2119653-1 | FEED CAM, POST FEED | 47 |
| - | 1 | 1 | 1 | 1 | 1 | 2119656-9 | APPLICATOR BASIC ASSEMBLY, SF | 46 |
| - | 1 | - | 1 | 1 | 1 | 2119370-1 | RAM, AMP STYLE, SIDE FEED | 44 |
| - | 1 | 1 | 1 | 1 | 1 | 2079383-7 | SCR, BHSC, RoHS (M8 X 25) | 41 |
| - | 1 | - | 1 | 1 | 1 | 2119645-1 | DISC, NUMBERED FA WIRE ADJUSTMENT | 40 |
| - | 1 | - | 1 | 1 | 1 | 2119957-1 | APPLICATOR SHIM PACK | 39 |
| - | 1 | 1 | 1 | 1 | 1 | 1-2119644-4 | RAM WASHER, PRECISION | 38 |
| - | 1 | 1 | 1 | 1 | 1 | 2119085-1 | FA HEAD, ATLANTIC STYLE | 37 |
| - | 1 | - | 1 | 1 | 1 | 2119092-1 | BOLT, ADJUSTMENT | 35 |
| - | 1 | 1 | 1 | 1 | 1 | 2-1752356-5 | SUPPORT, TERMINAL | 34 |
| - | 2 | 2 | 2 | 2 | 2 | 2079383-5 | SCR, BHSC, RoHS (M4 X 20) | 33 |
| - | 1 | 1 | 1 | 1 | 1 | 2161328-1 | HEX HEAD, FLANGED, M5 x 8mm LONG | 32 |
| - | 1 | 1 | 1 | 1 | 1 | 1320908-3 | SPACER, STRIP GUIDE | 30 |
| - | 1 | 1 | 1 | 1 | 1 | 2119959-1 | ASSEMBLY, STRIP GUIDE | 29 |
| - | 1 | 1 | 1 | 1 | 1 | 1320928-2 | STRIP GUIDE | 24 |
| - | 1 | 1 | 1 | 1 | 1 | 2168083-2 | SCR, SKT HD CAP, RoHS, M4 X 8.0 | 21 |
| - | 2 | 2 | 2 | 2 | 2 | 1-18028-2 | WASHER, FLAT, REG M4 | 20 |
| - | 1 | 1 | 1 | 1 | 1 | 2119533-1 | STRIPPER, SIDE FEED | 19 |
| - | 1 | 1 | 1 | 1 | 1 | 2119806-1 | INSERT, SHEAR | 13 |
| - | 1 | 1 | 1 | 1 | 1 | 3-22280-3 | SPRING, COMPRESSION | 12 |
| - | 1 | 1 | 1 | 1 | 1 | 1-356885-4 | STOP, SHEAR | 11 |
| - | 1 | 1 | 1 | 1 | 1 | 2119805-1 | SHEAR HOLDER, FRONT | 10 |
| - | 1 | 1 | 1 | 1 | 1 | 1803095-3 | FLOATING SHEAR, FRONT | 9 |
| - | 1 | 1 | 1 | 1 | 1 | 5-1803171-0 | ANVIL, COMBINATION | 8 |
| - | - | - | - | - | - | - | - | 7 |
| - | - | - | - | - | - | - | - | 6 |
| - | 1 | 1 | 1 | 1 | 1 | 2119757-5 | DEPRESSOR, SHEAR | 5 |
| - | 1 | 1 | 1 | 1 | 1 | 238011-8 | BLOCK, CRIMPER SPACER | 4 |
| - | 1 | 1 | 1 | 1 | 1 | 9-1633962-5 | CRIMPER, INSULATION F PREMIUM | 3 |
| - | 1 | 1 | 1 | 1 | 1 | 455888-1 | SPACER, CRIMPER | 2 |
| - | 1 | 1 | 1 | 1 | 1 | 8-1633730-3 | CRIMPER, WIRE | 1 |

| DIMENSIONS: | TOLERANCES UNLESS OTHERWISE SPECIFIED: | OWN | CHK | DATE | NAME | SIZE | CAGE CODE | DRAWING NO | RESTRICTED TO |
|-------------|--|--------|-----------|------------|--|-------|-----------|--------------|---------------|
| mm | 0 PLC ±.5 1 PLC ±0.5 2 PLC ±0.13 3 PLC ±0.013 4 PLC ±0.001 ANGLES ±.1 | STAKEM | G. BAILEY | 12JUNE2015 | Ocean Side Feed Applicator | A1 | 00779 | 2266814 | - |
| MATERIAL: | FINISH: | APVD | T. ELBIN | 12JUNE2015 | Customer Accessible Production Drawing | SCALE | 1:2 | SHEET 1 of 4 | REV A |

| LOC | | DIST | | REVISIONS | | | |
|-----|----|------|-----|-------------|------|-----|------|
| A | 66 | P | LYR | DESCRIPTION | DATE | OWN | APVD |
| | | - | | SEE SHEET 1 | | | |

FEED TYPE MECHANICAL

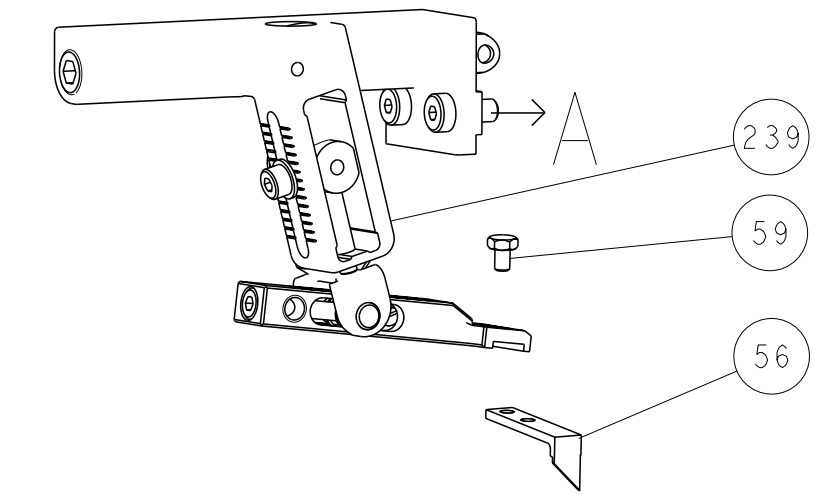

PNEUMATIC

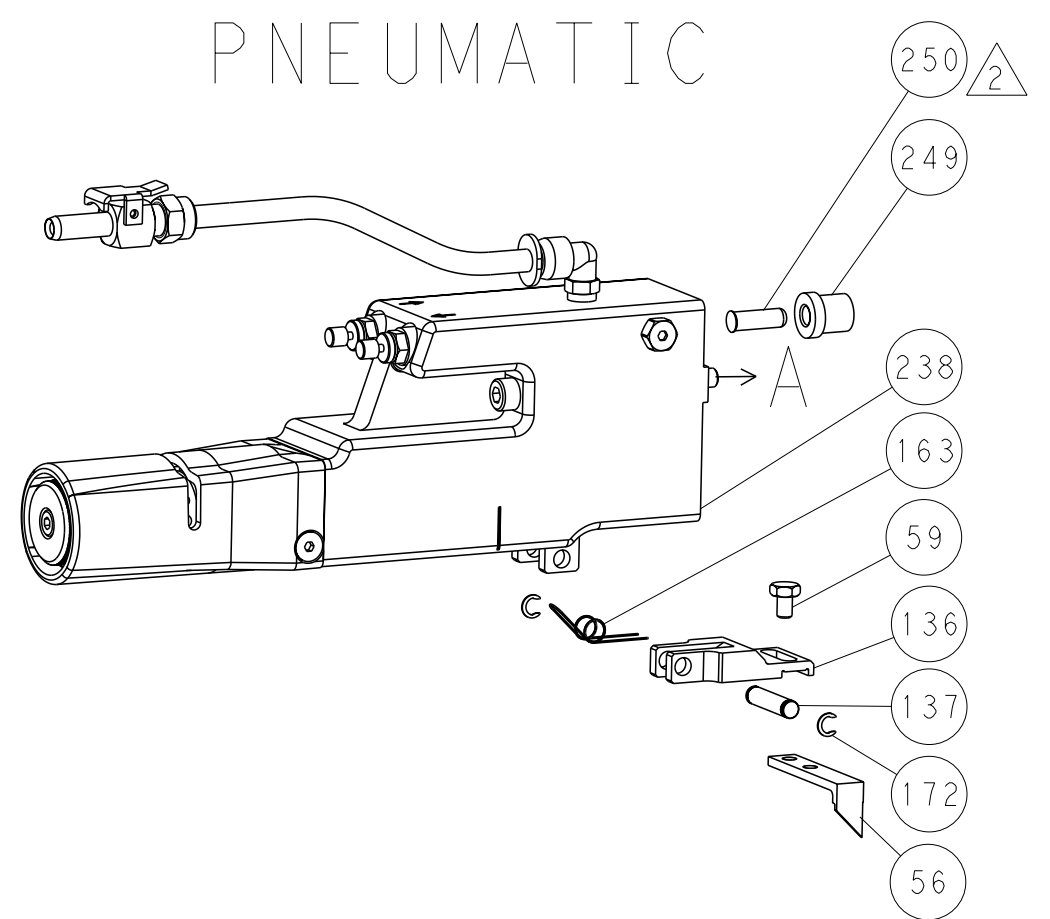

SERVO LATCH PLATE

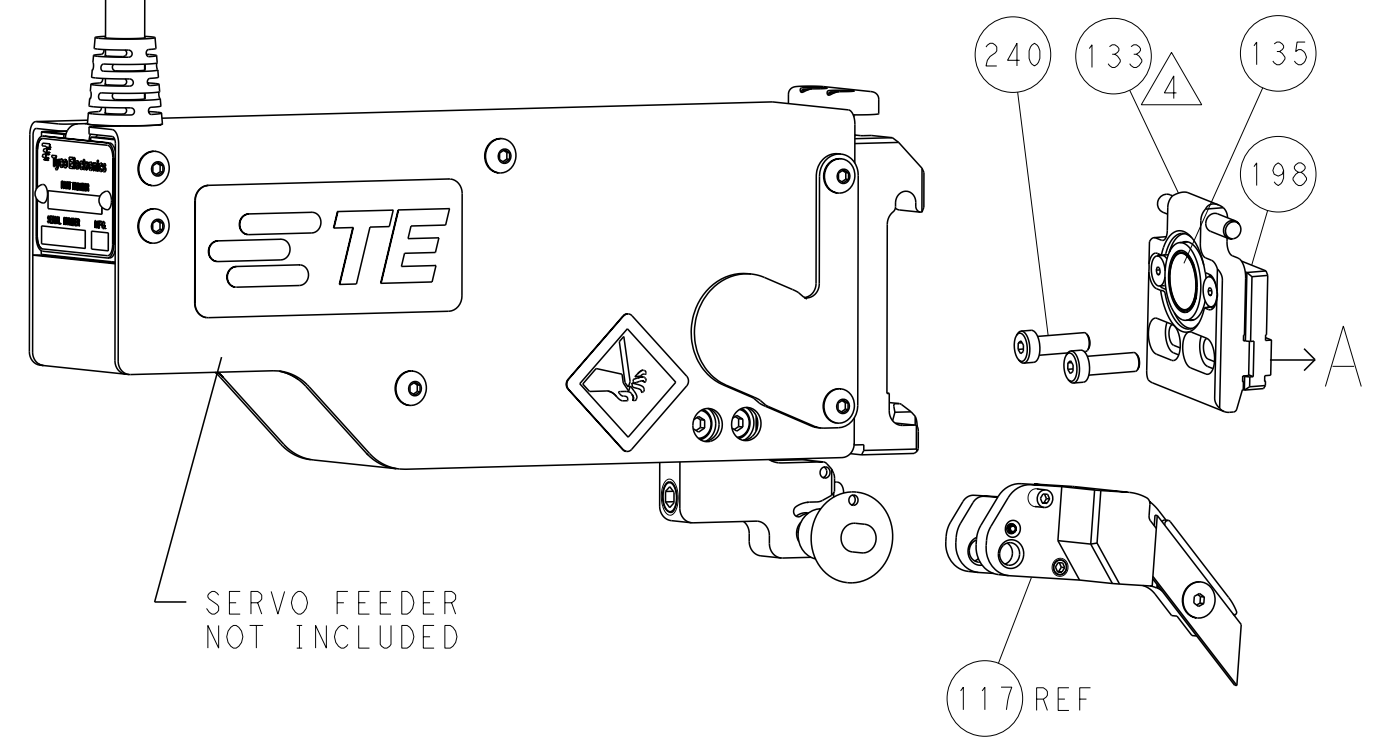

CAM POSITIONS

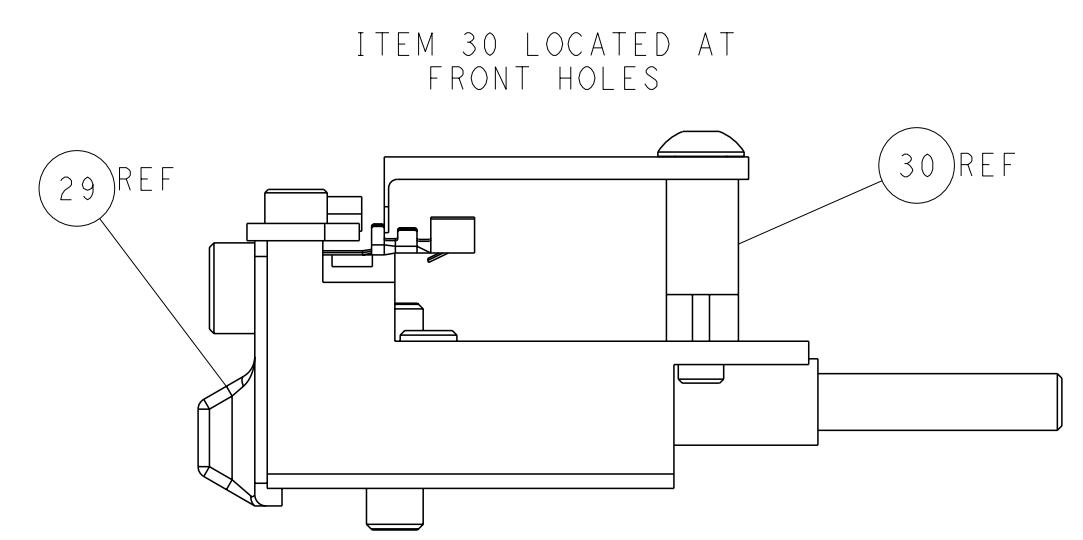
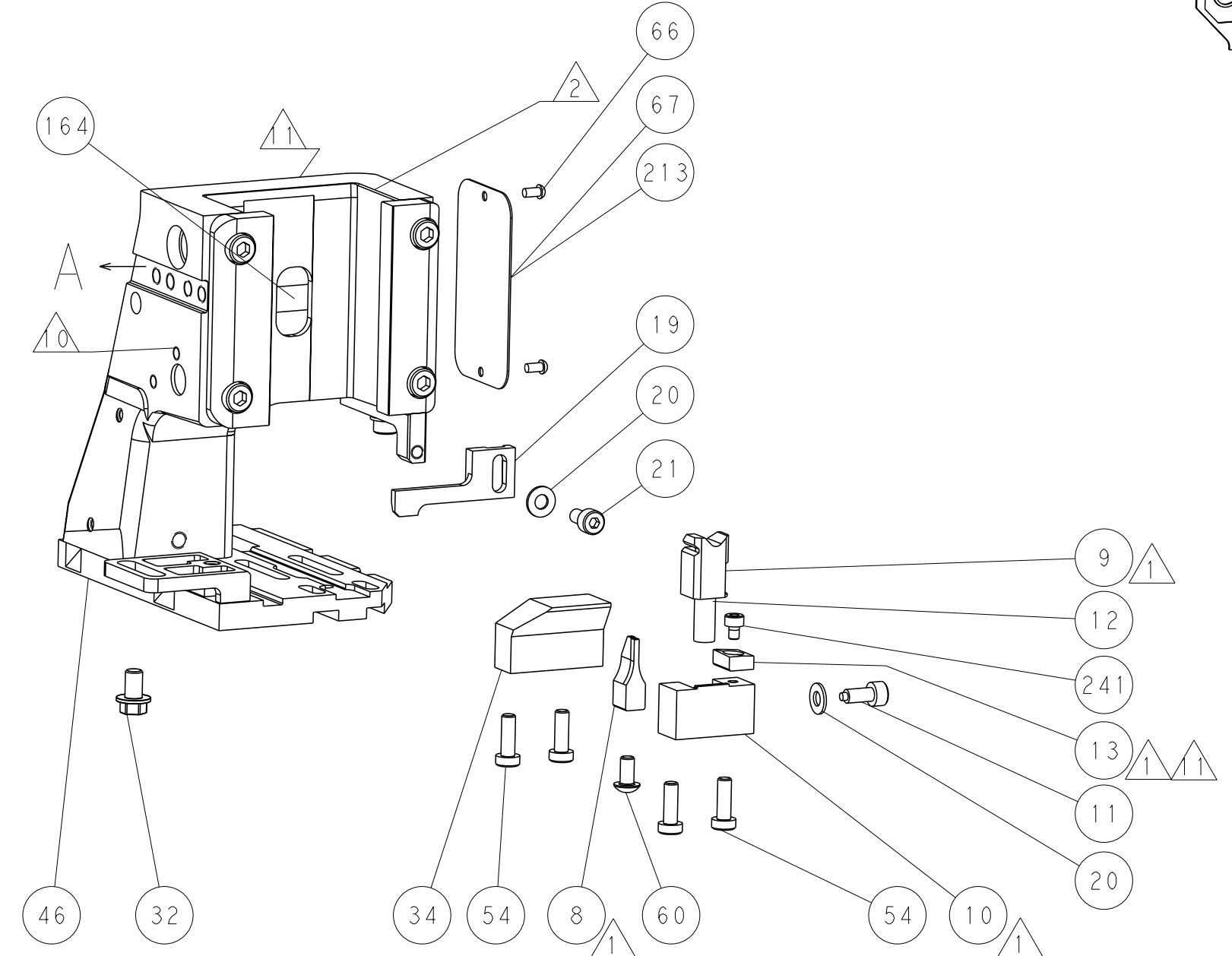
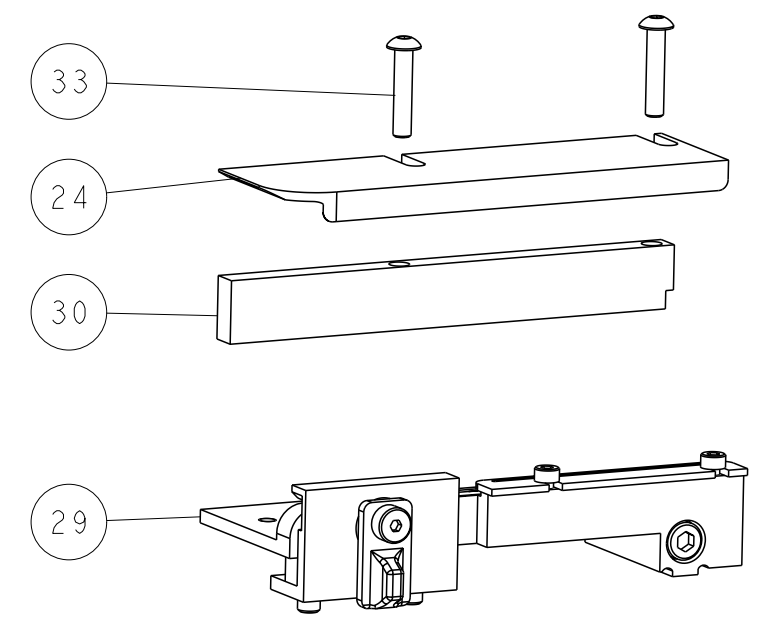
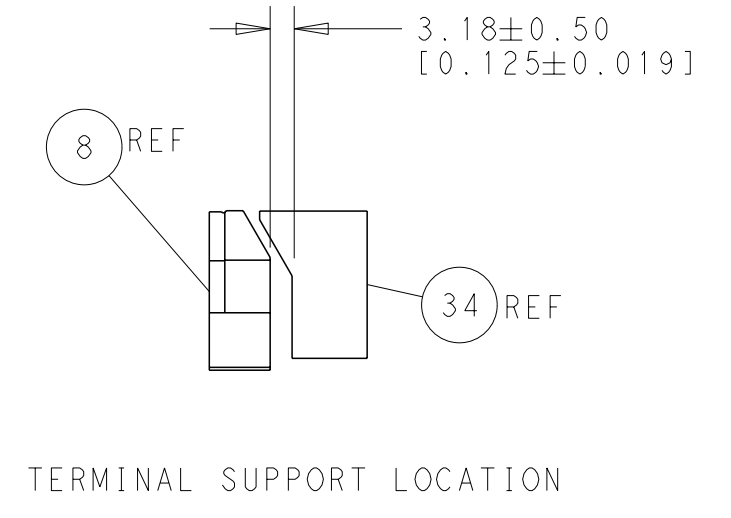
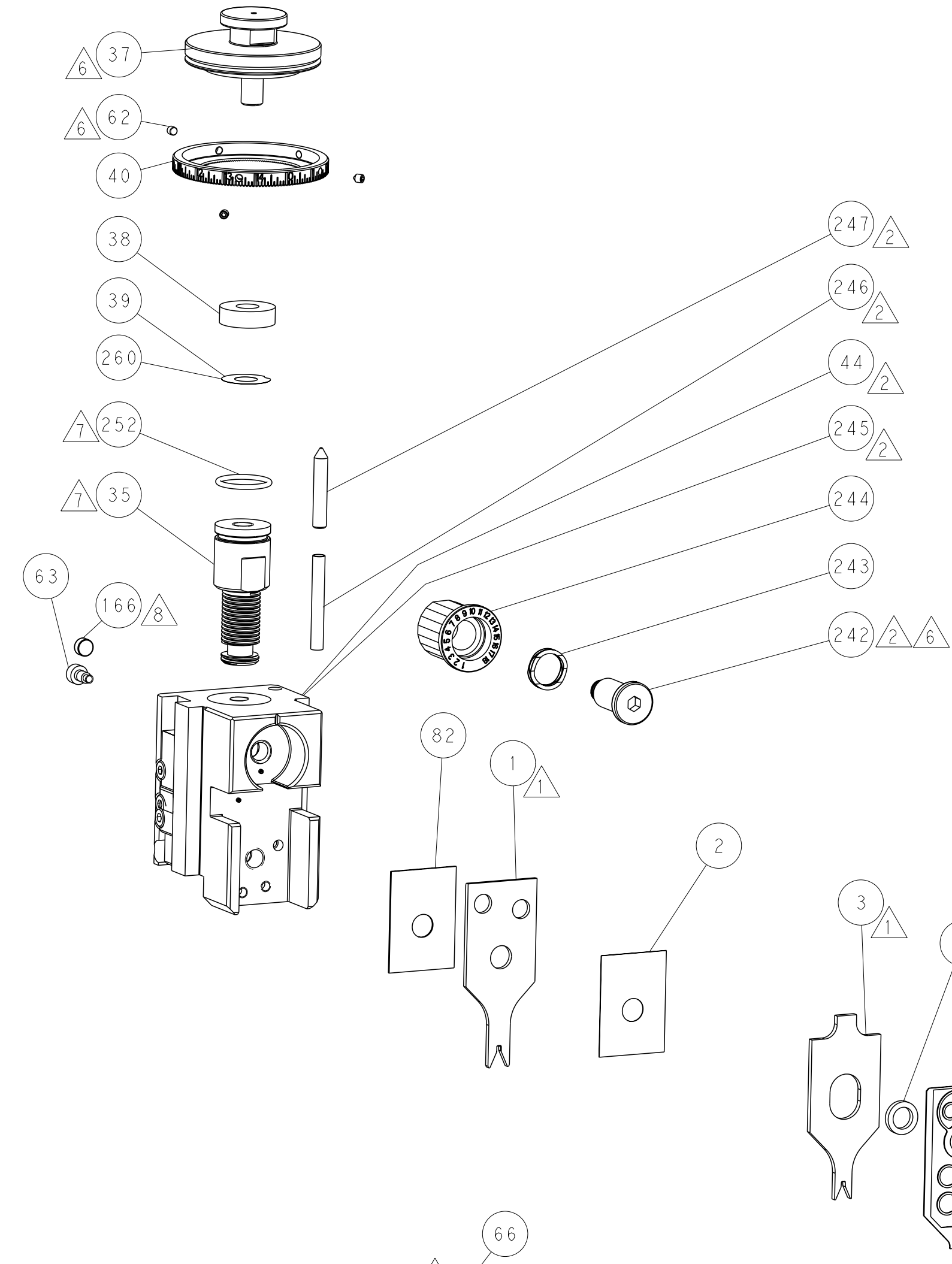
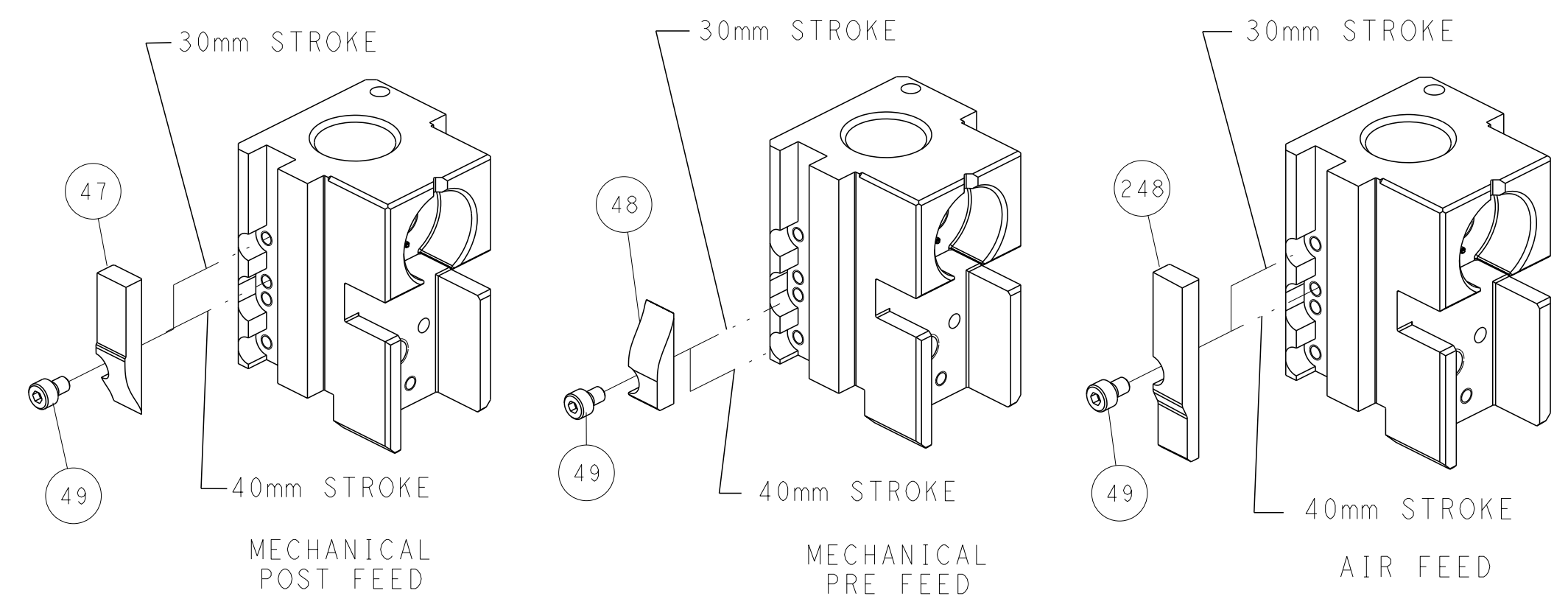

ATLANTIC VERSION
 Shown on sheets 1 of 4 & 2 of 4
 (Pacific version shown on sheets 3 of 4 & 4 of 4)

| | | | |
|--|--|---|---|
| <small>THIS DRAWING IS UNPUBLISHED. RELEASED FOR PUBLICATION 20 BY TYCO ELECTRONICS CORPORATION. ALL RIGHTS RESERVED.</small> | | DWN: R. STAKEM 12JUNE2015 CHK: G. BAILEY 12JUNE2015 APVD: T. ELBIN 12JUNE2015 | TE Connectivity Harrisburg, PA 17105-3608 |
| DIMENSIONS: mm TOLERANCES UNLESS OTHERWISE SPECIFIED: 0 PLC ±0.5 2 PLC ±0.13 3 PLC ±0.013 4 PLC ±0.0001 ANGLES FINISH: - | | NAME: Ocean Side Feed Applicator SIZE: A1 CAGE CODE: 00779 DRAWING NO: C=2266814 | RESTRICTED TO: - SCALE: 1:2 SHEET: 2 of 4 REV: A |
| MATERIAL: - FINISH: - | | WEIGHT: - Customer Accessible Production Drawing | SHEETS 3 & 4 ARE NOT REQUIRED FOR ATLANTIC VERSION |

THIS DRAWING IS UNPUBLISHED. RELEASED FOR PUBLICATION. BY TYCO ELECTRONICS CORPORATION. ALL RIGHTS RESERVED.

| PACIFIC VERSION TERMINATOR INTERFACE ADAPTER | PART NUMBER | REVISION | DESCRIPTION | FEED TYPE | APPLICATOR STYLE CONVERSION CHART | | | | | | |
|--|-------------|----------|--------------------------|--------------------------------|-----------------------------------|-----------------------|-----------|-------------|-----------|-----------|------------------------|
| | | | | | CONVERT TO | PART NUMBERS REQUIRED | | | | | |
| | 2-2266814-1 | A | FINE CRIMP HEIGHT ADJUST | MECHANICAL | PNEUMATIC FEED | 2119950-1 | 1338685-1 | 5-18022-5 | 2119641-2 | 2119799-1 | 2063440-1 |
| | | | | | SERVO LATCH PLATE | 2119951-1 | - | 8-2266814-5 | 1901094-3 | - | 2168400-6 (QUANTITY 2) |
| | | | | | SMART APPLICATOR | 2161326-1 | - | 8-2266814-4 | - | - | - |
| | 2-2266814-2 | A | FINE CRIMP HEIGHT ADJUST | PNEUMATIC | MECHANICAL FEED | 2119949-1 | 1338685-1 | 5-18022-5 | 2119653-2 | - | - |
| | | | | | SERVO LATCH PLATE | 2119951-1 | - | 8-2266814-5 | 1901094-3 | - | 2168400-6 (QUANTITY 2) |
| | | | | | SMART APPLICATOR | 2161326-1 | - | 8-2266814-4 | - | - | - |
| | 2-2266814-5 | A | FINE CRIMP HEIGHT ADJUST | SERVO LATCH PLATE ⁴ | MECHANICAL FEED | 2119949-1 | 1338685-1 | 5-18022-5 | 2119653-2 | - | - |
| | | | | | PNEUMATIC FEED | 2119950-1 | 1338685-1 | 5-18022-5 | 2119641-2 | 2119799-1 | 2063440-1 |
| | 2-2266814-7 | A | FINE CRIMP HEIGHT ADJUST | NONE | - | - | - | - | - | - | - |
| | 7-2266814-7 | A | CRIMP TOOLING KIT | - | - | - | - | - | - | - | - |

| APPLICATOR DATA | | |
|-----------------------------------|----------------|------|
| CRIMP | SIZE | TYPE |
| WIRE | 1.47 mm (.058) | F |
| INSUL | 1.65 mm (.065) | F |
| APPLICATOR INSTRUCTIONS 408-10389 | | |

| TERMINAL DATA: JST TERMINAL | | JST CRIMP SPECIFICATION | |
|------------------------------------|---------------------------|------------------------------|-----------------|
| TERMINAL NAME: TERMINAL | | | |
| WIRE STRIP LENGTH | | INSULATION DIAMETER RANGE | |
| 2.30-3.10 mm (.091-.122 IN) | | Ø1.20-1.80 mm (.047-.071 IN) | |
| TERMINAL APPLICATION SPECIFICATION | H4009/017-00 Rev 01-29-01 | | |
| TERMINALS APPLIED | | | |
| TE TERMINAL | JST TERMINAL | TE TERMINAL | JST TERMINAL |
| 286860-1 | SHF-001T-0.8BS | 286860-4 | SHF-001-0.8BS |
| 286860-2 | SHF-001T-0.8SS | 286860-5 | SHF-001G1-0.8BS |
| 286860-3 | SHF-001-0.8SS | | |

| WIRE SIZE | CRIMP HEIGHT mm [INCH] | CRIMP HEIGHT REFERENCE SETTING ⁹ |
|-----------|---------------------------------|---|
| 22 AWG | 0.80 +/- 0.05 [0.031 +/- .002] | 5.1 |
| 24 AWG | 0.75 +/- 0.05 [0.030 +/- .002] | 5.6 |
| 26 AWG | 0.70 +/- 0.05 [0.028 +/- .002] | 6.2 |
| 28 AWG | 0.68 +/- 0.025 [0.027 +/- .001] | 6.4 |

- RECOMMENDED SPARE PARTS
- GREASE BEARING SURFACES LIGHTLY
- 3. LUBRICATE DAILY PER THE APPLICATOR INSTRUCTION SHEET SUPPLIED WITH THE APPLICATOR.
- APPLICATOR SPECIFIC DATA TO BE ENTERED INTO BLANK MEMORY CHIP AT ASSEMBLY. SEE BELOW FOR PART NUMBER:
 MECHANICAL FEED WITH "SMART APPLICATOR" CONVERSION: 8-2266814-4
 PNEUMATIC FEED WITH "SMART APPLICATOR" CONVERSION: 8-2266814-4
 SERVO FEED WITH "FINE CRIMP HEIGHT ADJUST": 8-2266814-5
- 5. ADJUSTMENT OF THE STRIPPER MAY BE REQUIRED WHEN MOVING THE APPLICATOR BETWEEN BENCH AND LEADMAKER APPLICATIONS.
- APPLY PART NUMBER 1-23419-5 LOCTITE TO THREADS OF ITEM 62. APPLY PART NUMBER 2-23419-6 LOCTITE TO THREADS OF ITEM 242.
- GREASE THREADS, GROOVE AND O-RING ON ITEMS 139 & 152.
- MAGNET MUST BE ORIENTED CORRECTLY IN ORDER TO PROPERLY ACTUATE THE COUNTER.
- CRIMP HEIGHT REFERENCE SETTING WAS THE SETTING USED WHEN THE APPLICATOR WAS QUALIFIED AT THE FACTORY. ADJUSTMENT MAY BE NECESSARY WHEN RUNNING APPLICATOR IN THE FIELD.
- SPARE FEED CAM STORAGE LOCATION REFER TO INSTRUCTION SHEET FOR ADDITIONAL INFORMATION.
- TO CONVERT THE APPLICATOR TO A NON-CARRIER CUTTING STYLE, REMOVE ITEM 13 AND ATTACH TO THE LOCATION ON BACK SIDE OF THE HOUSING. REFER TO INSTRUCTION SHEET FOR ADDITIONAL INFORMATION.

***WARNING**
 ON INSTALLATION, SET WIRE DISC, ITEM 40 TO LARGEST WIRE SIZE SETTING. USE OF SETTINGS BELOW MINIMUM REQUIRED CRIMP HEIGHT SETTING WILL CAUSE DAMAGE TO CRIMP TOOLING.

PACIFIC VERSION
 Shown on sheets 3 of 4 & 4 of 4
 (Atlantic version shown on sheets 1 of 4 & 2 of 4)

| SET UP GAUGE | LOC | DIST | REVISIONS | | | |
|--------------|-----|------|-----------|-------------|----|------|
| 2119599-1 | A | 66 | # | DATE | BY | APPV |
| | | | - | SEE SHEET 1 | - | - |

| | | | | | | | |
|---|-----|-----|-----|-----|-------------|-------------------------------------|-----|
| - | 1 | 1 | 1 | 1 | 2119782-1 | FINE ADJUST HEAD ASM, PACIFIC STYLE | 251 |
| - | - | - | 1 | - | 2119640-1 | PUSH ROD, AIR FEED | 250 |
| - | - | - | 1 | - | 2079988-1 | BUSHING, LCH5-12, MISUMI | 249 |
| - | 1 | 1 | 1 | 1 | 1-22279-3 | SPRING, COMPRESSION | 246 |
| - | 1 | 1 | 1 | 1 | 2119082-4 | CAM, SNAIL, INSULATION ADJUSTMENT | 244 |
| - | 1 | 1 | 1 | 1 | 2079764-1 | WASHER, WAVE SPRING, CREST-TO-CREST | 243 |
| - | 1 | 1 | 1 | 1 | 2119083-1 | RETAINER, INSULATION DIAL | 242 |
| - | 1 | 1 | 1 | 1 | 7-18023-7 | SCR, SKT HD CAP M3 X 4.0 | 241 |
| - | - | 2 | - | - | 2168400-6 | SHCS, LOW HEAD, RoHS, M5 X 16 | 240 |
| - | - | - | - | 1 | 2119580-1 | MECHANICAL FEED ASSEMBLY | 239 |
| - | - | - | 1 | - | 2063440-1 | AIR FEED MODULE | 238 |
| - | - | 1 | - | - | 2119740-2 | TAG, IDENTIFICATION | 213 |
| - | - | 1 | - | - | 1901094-3 | SPACER, FEEDER | 198 |
| - | - | - | 2 | - | 21045-3 | RING, RETAIN, EXTERN, 3/16 CRESCENT | 172 |
| - | 1 | 1 | 1 | 1 | 994969-1 | MAGNET, RARE EARTH HIGH ENERGY | 166 |
| - | REF | REF | REF | REF | 994970-2 | COUNTER, MAGNETIC | 164 |
| - | - | - | 1 | - | 240638-1 | SPRING, FEED FINGER | 163 |
| - | 1 | 1 | 1 | 1 | 8-21084-1 | O-RING, .801 ID, .070 DIA, MAT. | 152 |
| - | - | - | 1 | - | 2119641-2 | FEED CAM, AIR FEED | 151 |
| - | 1 | 1 | 1 | 1 | 2119798-2 | DETENT PIN | 145 |
| - | 1 | 1 | 1 | 1 | 2079383-8 | SCR, BHSC, RoHS (M4 X 16) | 144 |
| - | 4 | 4 | 4 | 4 | 2168400-5 | SHCS, LOW HEAD, RoHS, M4 X 20 | 143 |
| - | - | - | - | 1 | 2119653-2 | FEED CAM, POST FEED | 142 |
| - | 1 | 1 | 1 | 1 | 1-2119656-0 | APPLICATOR BASIC ASSEMBLY, SF | 141 |
| - | 1 | 1 | 1 | 1 | 2119650-1 | RAM, ASIAN STYLE, SIDE FEED | 140 |
| - | 1 | 1 | 1 | 1 | 2119092-2 | BOLT, ADJUSTMENT | 139 |
| - | - | - | 1 | - | 3-23627-7 | PIN, RETAIN, GRVD, 3/16 X .854 | 137 |
| - | - | - | 1 | - | 2119799-1 | HOLDER, FEED FINGER, AF | 136 |
| - | - | REF | - | - | SEE NOTE 4 | MEMORY CHIP, PROGRAMMED | 135 |
| - | - | 1 | - | - | 1633743-1 | SERVO FEED LATCH ASM | 133 |
| - | - | REF | - | - | 2119944-1 | FEED FINGER ASSEMBLY, SF | 117 |
| - | 1 | 1 | 1 | 1 | 455888-5 | SPACER, CRIMPER | 82 |
| - | 1 | 1 | 1 | 1 | 2119956-1 | DOCUMENTATION PACKAGE | 71 |
| - | 1 | 1 | 1 | 1 | 2119791-5 | DEPRESSOR, WIRE | 70 |
| - | 1 | - | 1 | 1 | 2119740-1 | TAG, IDENTIFICATION | 67 |
| - | 2 | 2 | 2 | 2 | 2168078-1 | SCREW, DRIVE, RH, RoHS, 2 x .188 | 66 |
| - | 1 | 1 | 1 | 1 | 2119793-1 | LIMITER, ADJUSTMENT BOLT | 63 |
| - | 3 | 3 | 3 | 3 | 992763-5 | SCR, SET, SOC, CONE POINT, M3 x 4.0 | 62 |
| - | - | - | 1 | 1 | 5-18022-5 | SCR, HEX HD CAP, M4 X 6.0 | 59 |
| - | - | - | 1 | 1 | 1338685-1 | PAWL, FEED | 56 |
| - | - | - | 1 | 2 | 18023-9 | SCR, SKT HD CAP M4 X 6.0 | 49 |
| - | - | - | - | 1 | 2119652-1 | FEED CAM, PRE FEED | 48 |
| - | 1 | 1 | 1 | 1 | 2079383-7 | SCR, BHSC, RoHS (M8 X 25) | 41 |
| - | 1 | 1 | 1 | 1 | 2119645-1 | DISC, NUMBERED FA WIRE ADJUSTMENT | 40 |
| - | 1 | 1 | 1 | 1 | 2119957-1 | APPLICATOR SHIM PACK | 39 |
| - | 1 | 1 | 1 | 1 | 1-2119644-4 | RAM WASHER, PRECISION | 38 |
| - | 1 | 1 | 1 | 1 | 2-1752356-5 | SUPPORT, TERMINAL | 34 |
| - | 2 | 2 | 2 | 2 | 2079383-5 | SCR, BHSC, RoHS (M4 X 20) | 33 |
| - | 1 | 1 | 1 | 1 | 2161328-1 | HEX HEAD, FLANGED, M5 x 8mm LONG | 32 |
| - | 1 | 1 | 1 | 1 | 1320908-3 | SPACER, STRIP GUIDE | 30 |
| - | 1 | 1 | 1 | 1 | 2119959-1 | ASSEMBLY, STRIP GUIDE | 29 |
| - | 1 | 1 | 1 | 1 | 1320928-2 | STRIP GUIDE | 24 |
| - | 1 | 1 | 1 | 1 | 2168083-2 | SCR, SKT HD CAP, RoHS, M4 X 8.0 | 21 |
| - | 2 | 2 | 2 | 2 | 1-18028-2 | WASHER, FLAT, REG M4 | 20 |
| - | 1 | 1 | 1 | 1 | 2119533-1 | STRIPPER, SIDE FEED | 19 |
| - | 1 | 1 | 1 | 1 | 2119806-1 | INSERT, SHEAR | 13 |
| - | 1 | 1 | 1 | 1 | 3-22280-3 | SPRING, COMPRESSION | 12 |
| - | 1 | 1 | 1 | 1 | 1-356885-4 | STOP, SHEAR | 11 |
| - | 1 | 1 | 1 | 1 | 2119805-1 | SHEAR HOLDER, FRONT | 10 |
| - | 1 | 1 | 1 | 1 | 1803095-3 | FLOATING SHEAR, FRONT | 9 |
| - | 1 | 1 | 1 | 1 | 5-1803171-0 | ANVIL, COMBINATION | 8 |
| - | - | - | - | - | - | - | 7 |
| - | - | - | - | - | - | - | 6 |
| - | 1 | 1 | 1 | 1 | 2119757-5 | DEPRESSOR, SHEAR | 5 |
| - | 1 | 1 | 1 | 1 | 238011-8 | BLOCK, CRIMPER SPACER | 4 |
| - | 1 | 1 | 1 | 1 | 9-1633962-5 | CRIMPER, INSULATION F PREMIUM | 3 |
| - | 1 | 1 | 1 | 1 | 455888-1 | SPACER, CRIMPER | 2 |
| - | 1 | 1 | 1 | 1 | 8-1633730-3 | CRIMPER, WIRE | 1 |

| DIMENSIONS: | TOLERANCES UNLESS OTHERWISE SPECIFIED: | OWN | CHK | DATE | NAME | SIZE | CAGE CODE | DRAWING NO | RESTRICTED TO |
|-------------|---|--------|-----------|------------|--|-------|-----------|--------------|---------------|
| mm | 0 PLC ±.5 1 PLC ±0.5 2 PLC ±0.13 3 PLC ±0.013 4 PLC ±0.0001 ANGLES ±.5 | STAKEM | G. BAILEY | 12JUNE2015 | Ocean Side Feed Applicator | A1 | 00779 | 2266814 | - |
| MATERIAL: | FINISH: | APV | ELBIN | 12JUNE2015 | Customer Accessible Production Drawing | SCALE | 1:2 | SHEET 3 of 4 | REV A |

| REVISONS | | DATE | OWN | APVD |
|----------|------|-------------|-----|------|
| LOC | DIST | | | |
| A | 66 | | | |
| P | LYR | DESCRIPTION | | |
| - | - | SEE SHEET 1 | - | - |

FEED TYPE MECHANICAL

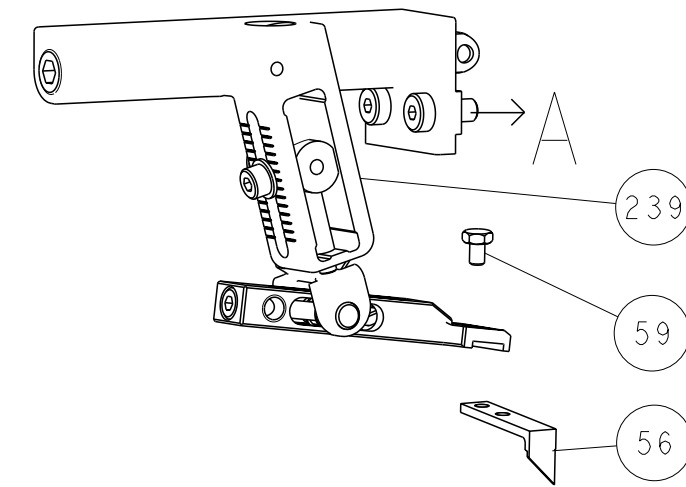

PNEUMATIC

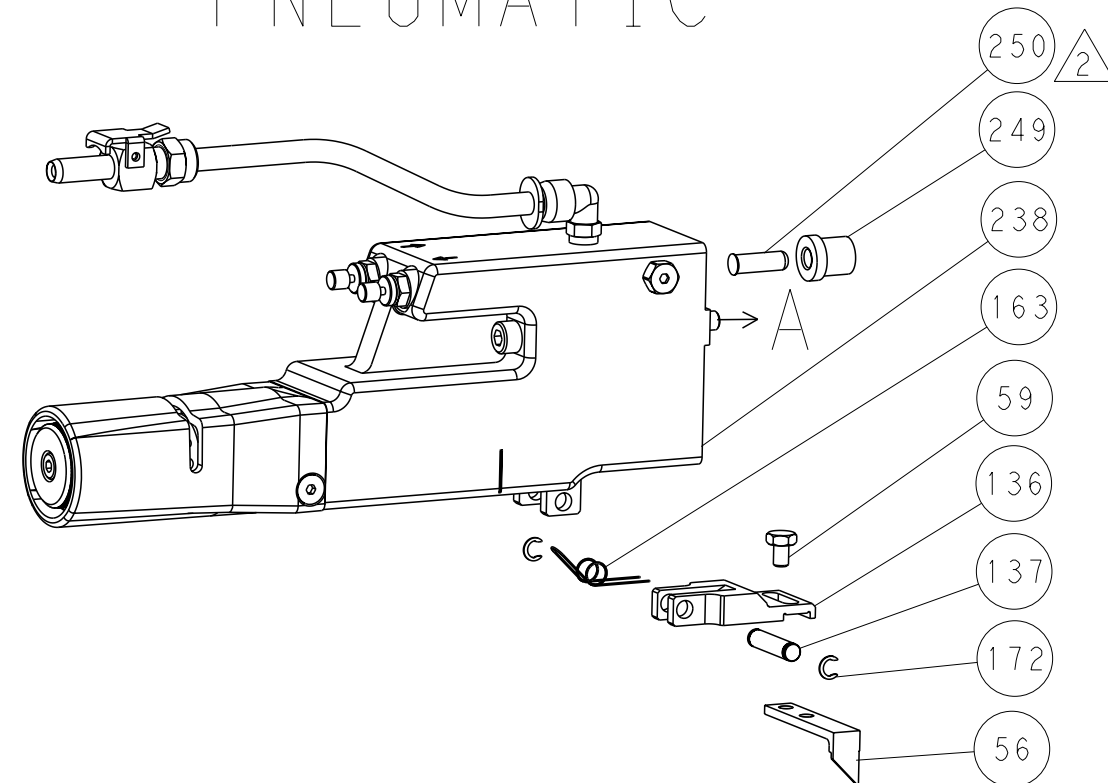

SERVO LATCH PLATE

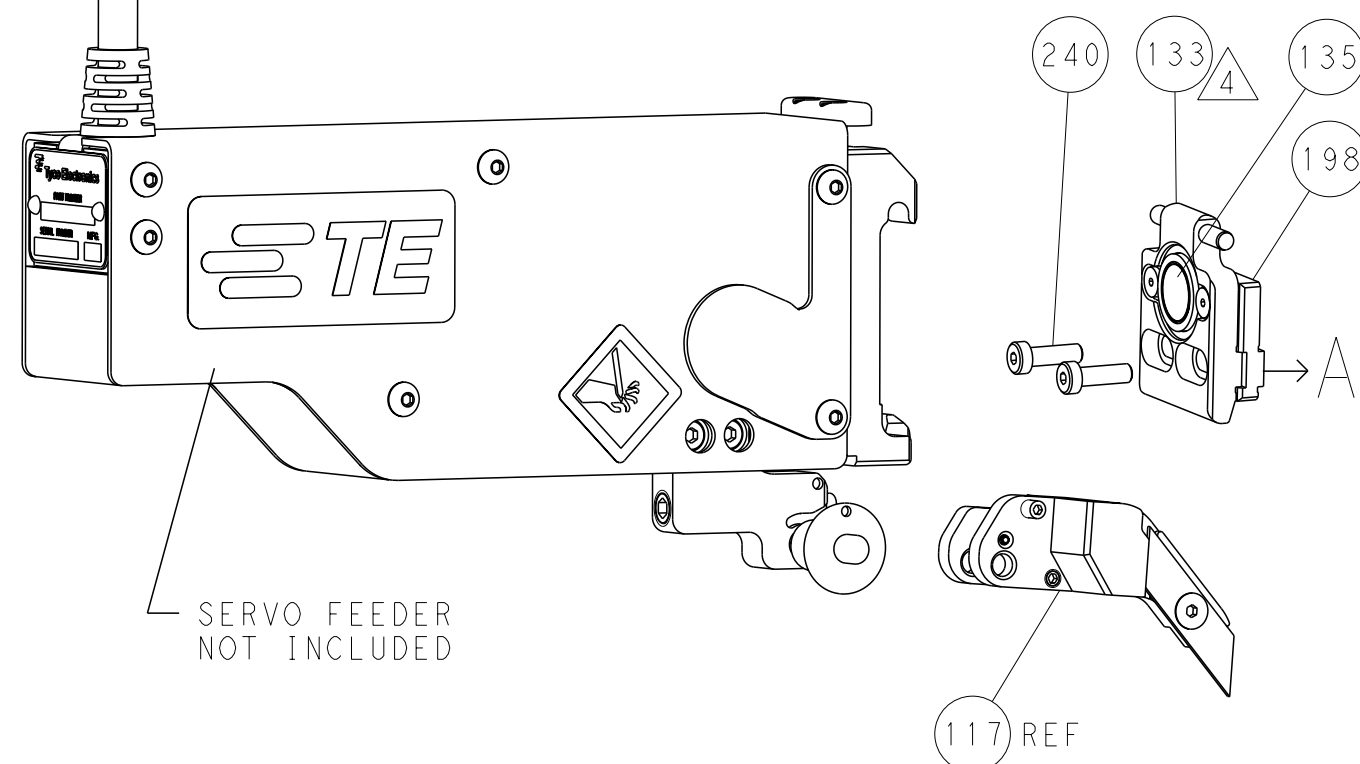

CAM POSITIONS

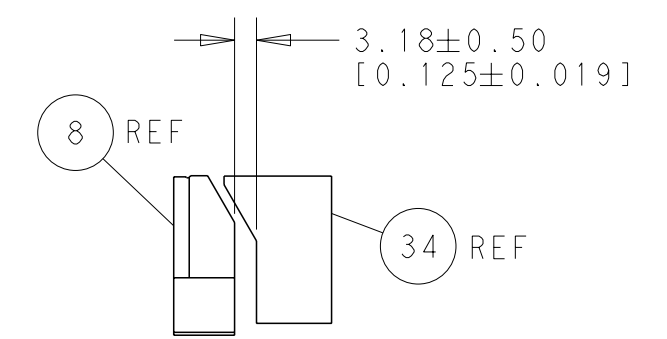
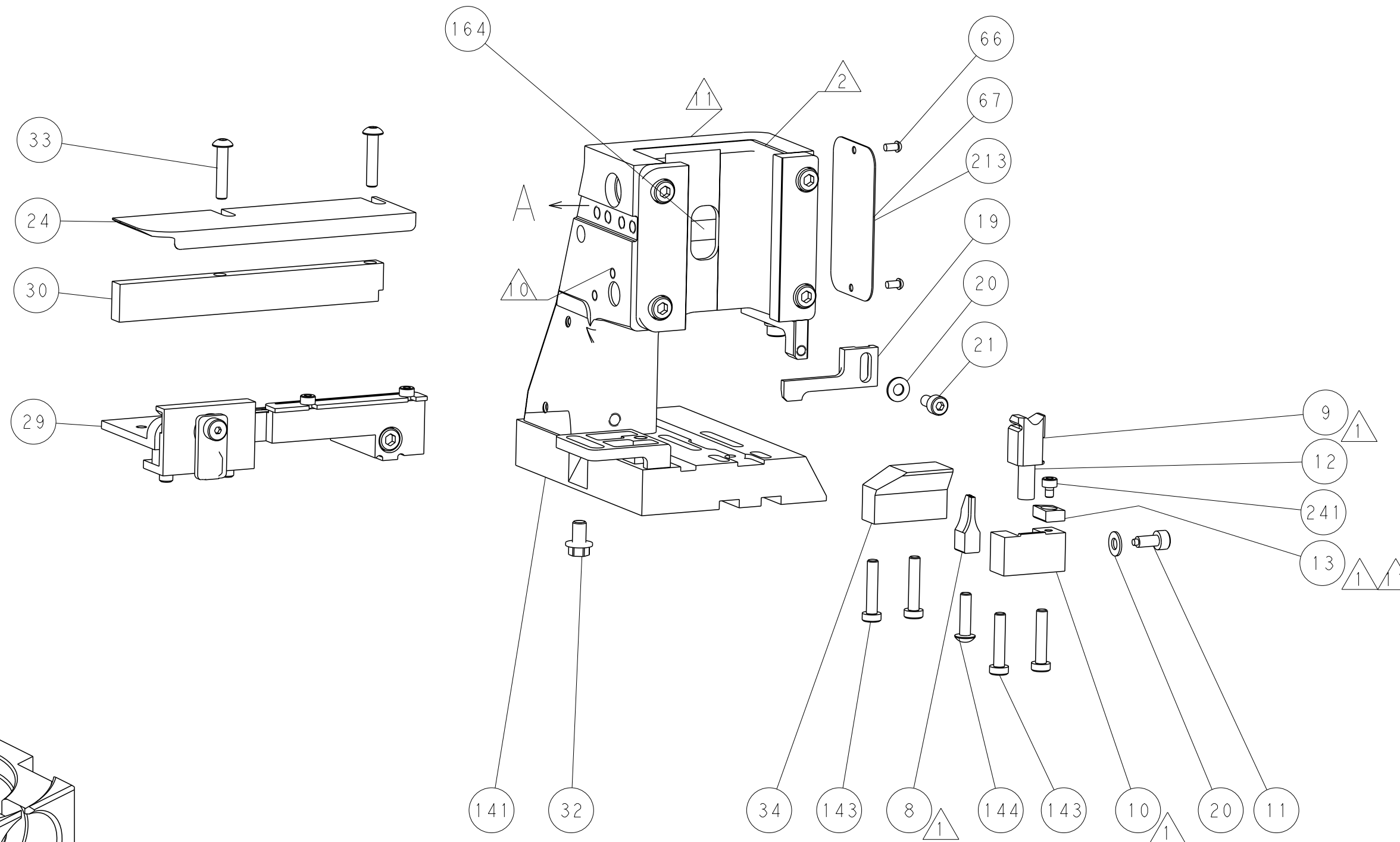
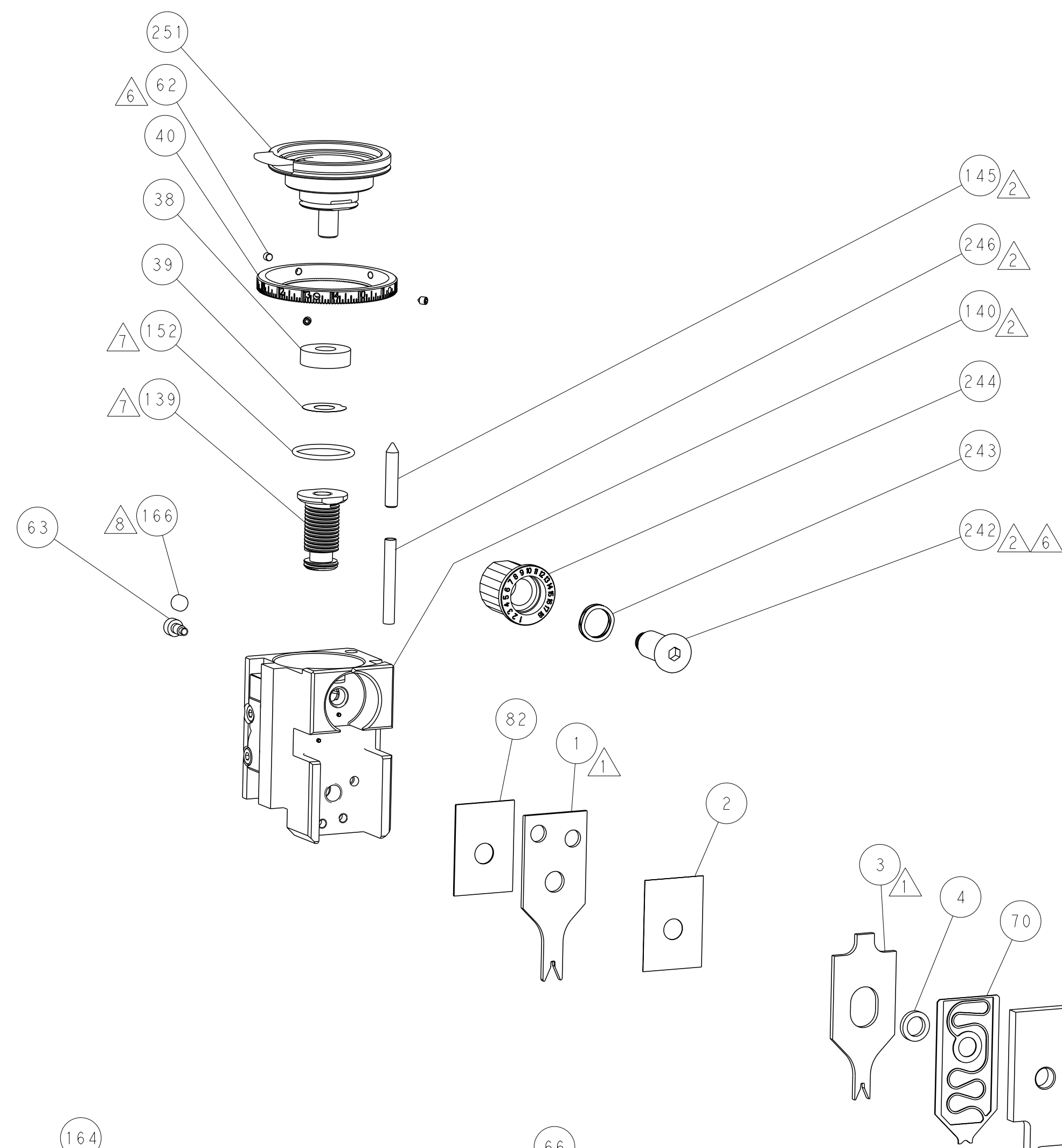
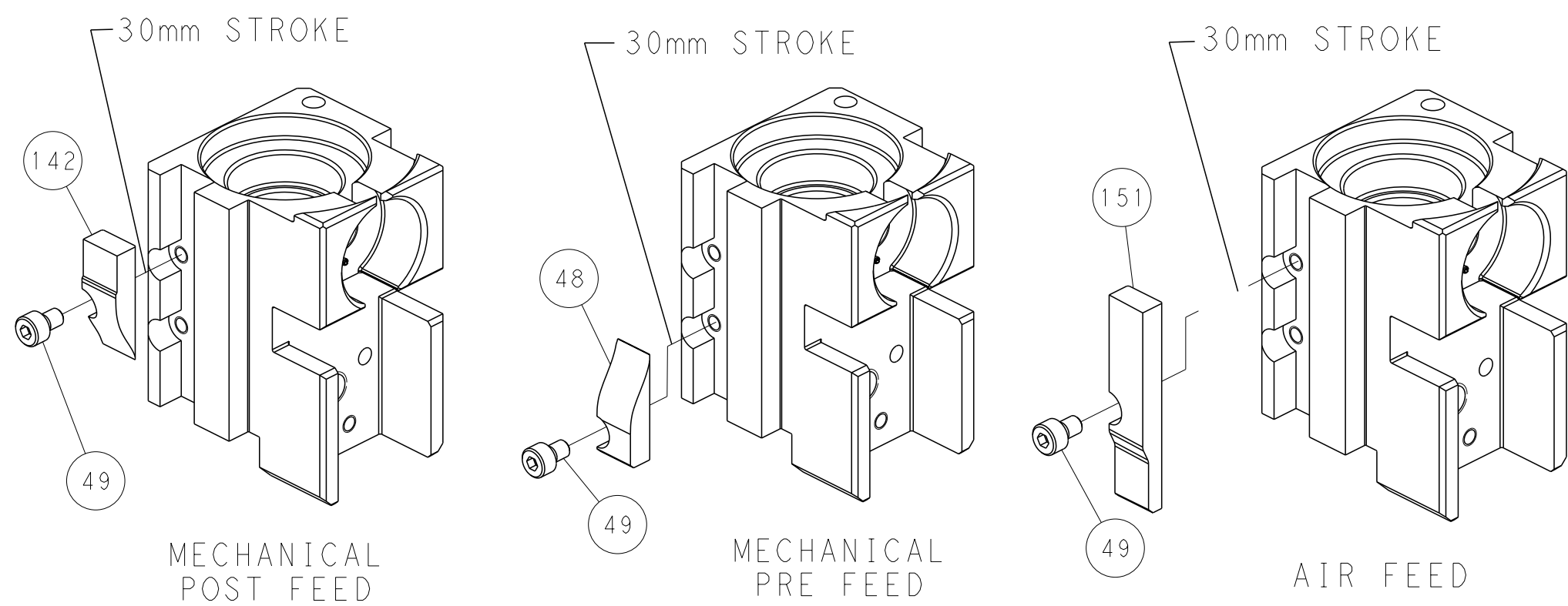

TERMINAL SUPPORT LOCATION

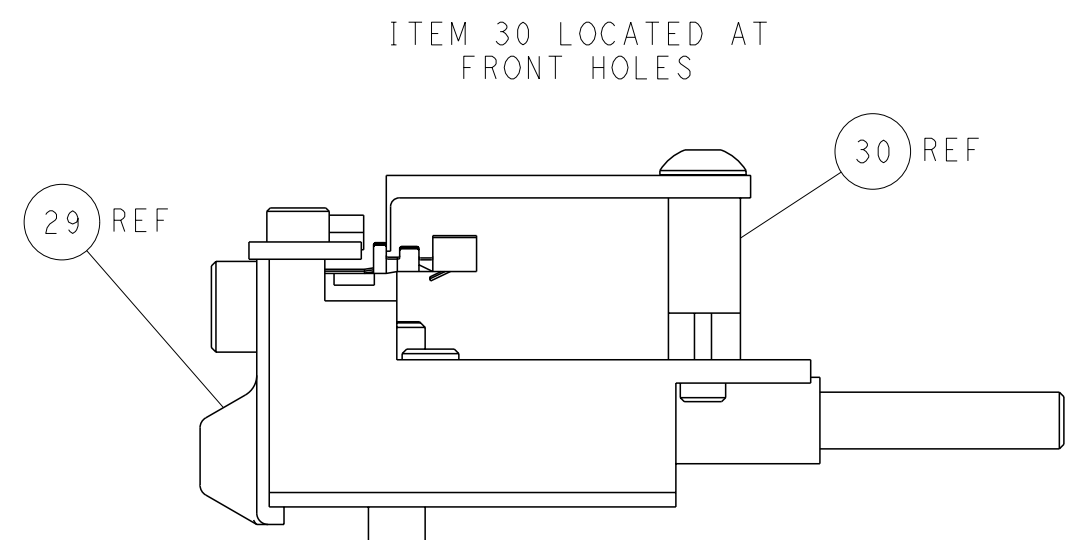

FEED TRACK POSITION
GUIDE BY INSULATION BARREL

PACIFIC VERSION
 Shown on sheets 3 of 4 & 4 of 4
 (Atlantic version shown on sheets 1 of 4 & 2 of 4)

| | | |
|--|--|--|
| <small>THIS DRAWING IS UNPUBLISHED. RELEASED FOR PUBLICATION. IT IS SUBJECT TO CHANGE AND THE CUSTOMER'S RESPONSIBILITY TO VERIFY DIMENSIONS AND TOLERANCES BEFORE PRODUCTION. DIMENSIONS SHOULD BE CONTACTED FOR THE LATEST REVISION.</small> | | OWN: H. STAKEM CHK: G. BAILEY APVD: T. ELBIN DATE: 12JUNE2015 NAME: Ocean Side Feed Applicator |
| DIMENSIONS: mm TOLERANCES UNLESS OTHERWISE SPECIFIED: 0 PLC ±.5 1 PLC ±0.5 2 PLC ±0.13 3 PLC ±0.013 4 PLC ±0.001 ANGLES FINISH: * | WEIGHT: - SCALE: 1:2 SHEET: 4 of 4 REV: A | SIZE: A1 CAGE CODE: 00779 DRAWING NO: C=2266814 RESTRICTED TO: - |
| Customer Accessible Production Drawing | | |