

THIS DOCUMENT CONTAINS DATA PROPRIETARY TO PROJECTS UNLIMITED, INC. ANY USE OR REPRODUCTION, IN ANY FORM, WITHOUT PRIOR WRITTEN PERMISSION OF PROJECTS UNLIMITED, INC. IS PROHIBITED.  
© 2003, Projects Unlimited Inc.

### SPECIFICATIONS

| PARAMETERS  | VALUES       | UNITS |
|---|--------------|-------|
| RATED INPUT POWER                                   | 3            | W     |
| MAX INPUT POWER                                     | 5            | W     |
| IMPEDANCE   | 8±15%        | OHM   |
| OUTPUT SPL @ 1W/0.5M<br>(AT 0.8, 1.0, 1.2, 1.5 kHz) | 86±3         | dB    |
| DISTORTION  | 5%           | —     |
| RESONANT FREQUENCY                                  | 250±70       | Hz    |
| FREQUENCY RANGE                                     | 100 ~ 20,000 | Hz    |
| HOUSING MATERIAL                                    | METAL        | —     |
| CONE MATERIAL                                       | PAPER        | —     |
| MAGNET MATERIAL                                     | Nd-Fe-B      | —     |
| OPERATING TEMPERATURE                               | -20 ~ +60    | °C    |
| WEIGHT  | 36           | grams |

| REVISIONS |                           |         |          |
|-----------|---------------------------|---------|----------|
| LTR       | DESCRIPTION               | DATE    | APPROVED |
| —         | RELEASED FROM ENGINEERING | 7/14/03 |          |
| A         | REVISED TO NEW TEMPLATE   | 4/16/04 | R. W.    |

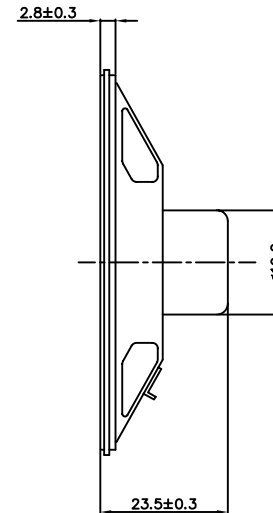
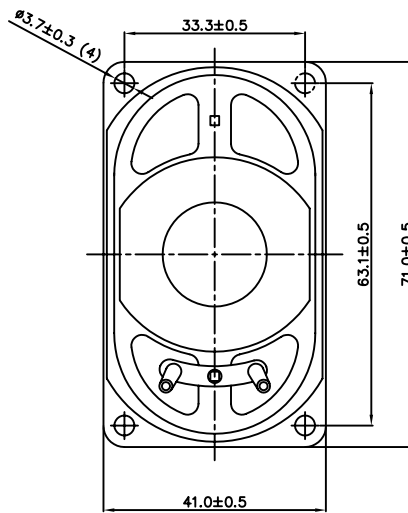

NOTES:

1. ALL DIMENSIONS ARE IN MILLIMETERS.
2. SPECIFICATION SUBJECT TO CHANGE OR WITHDRAWAL WITHOUT NOTICE.

FILE NAME  
AS704008-32.DWG

|   |  |  |               |  |  |
|---|--|--|---------------|--|--|
| UNLESS OTHERWISE SPECIFIED:<br>DIMENSIONS ARE IN MILLIMETERS,<br>TOLERANCES ARE ±0.5 AND ANGLES ARE<br>±3°. |  |  <b>projects®<br/>unlimited</b> |               | Dayton , Ohio  |  |
| APPROVALS   |  | DATE   |               | <p align="center"><b>DYNAMIC SPEAKER</b><br/>AS704008-32</p> <p align="center">DRAWING NO.<br/>AS704008-32</p> |  |
| DRAWN <i>T.P.I.</i>   |  | 7/03   |               |  |  |
| APPROVED <i>S.J.</i>  |  | 7/03   |               |  |  |
| DO NOT SCALE DRAWING  |  | SIZE<br>A  | SCALE: N.T.S. |  |  |
|   |  |  |               | SHEET 1 OF 1   |  |