

LOC	DIST	REV	DESCRIPTION	DATE	OWN	APVD
A	66		SEE SHEET 1			

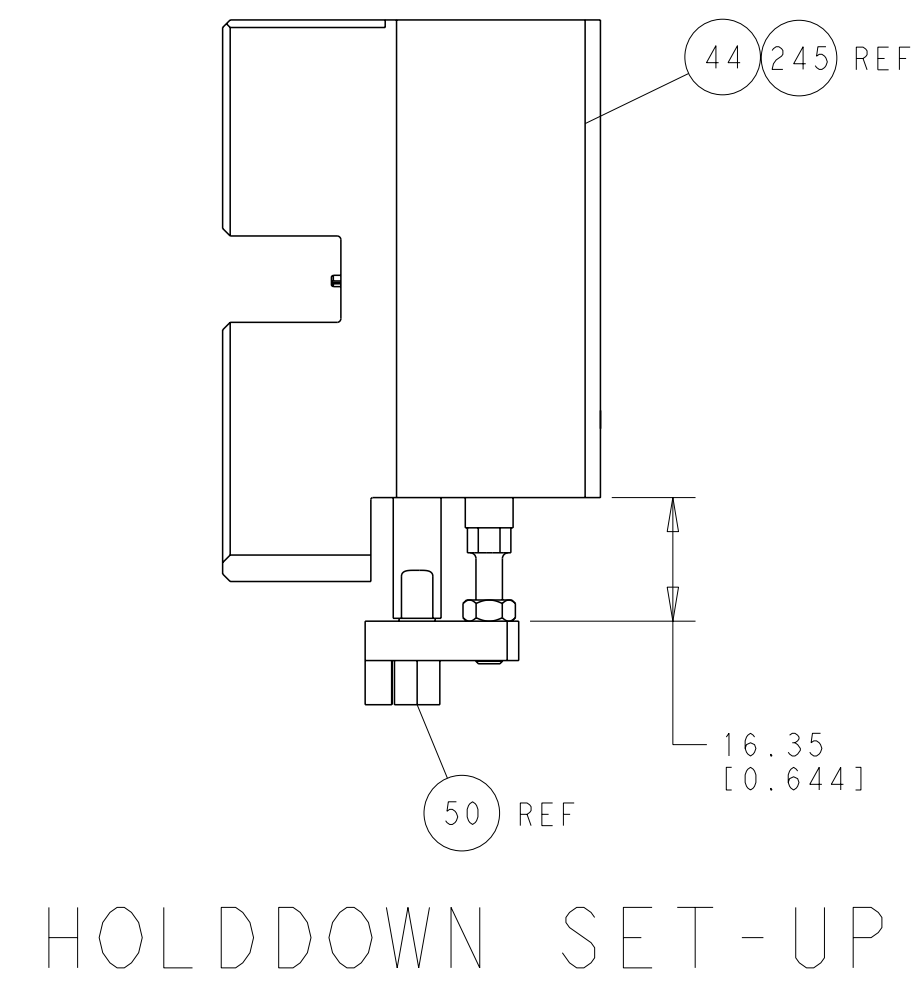

FEED TYPE MECHANICAL

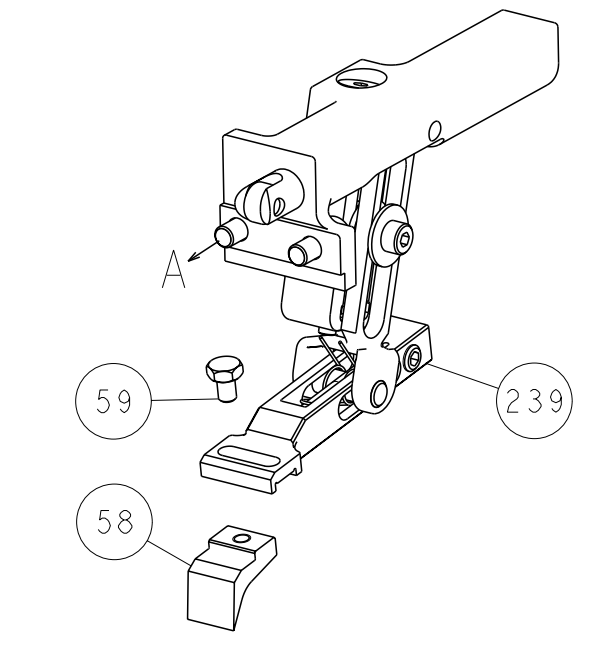

PNEUMATIC

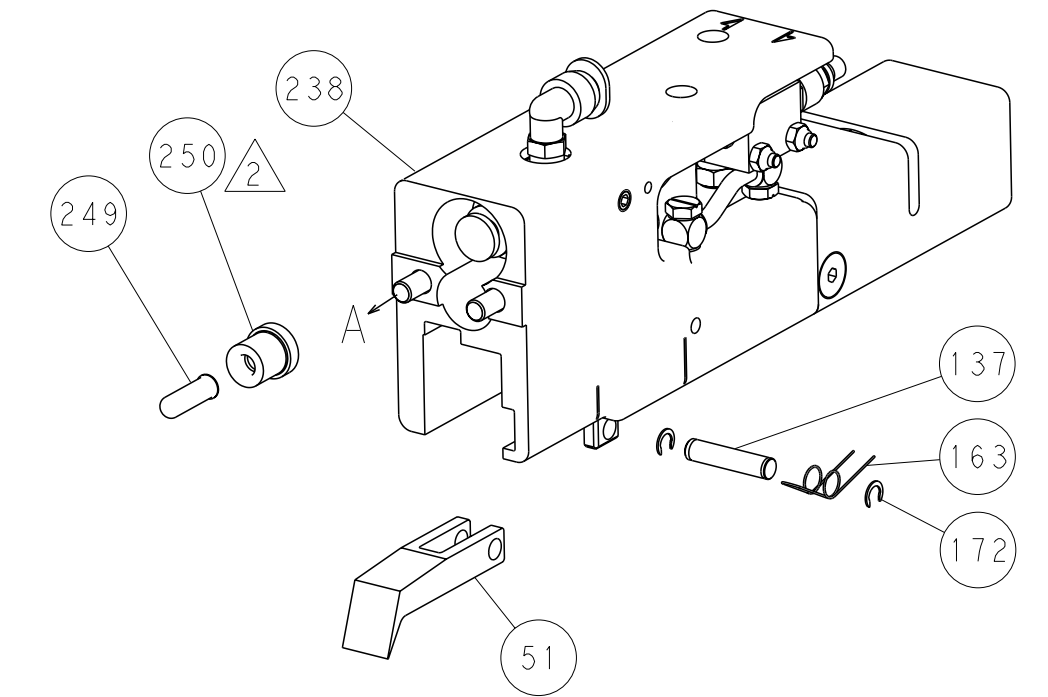

SERVO LATCH PLATE

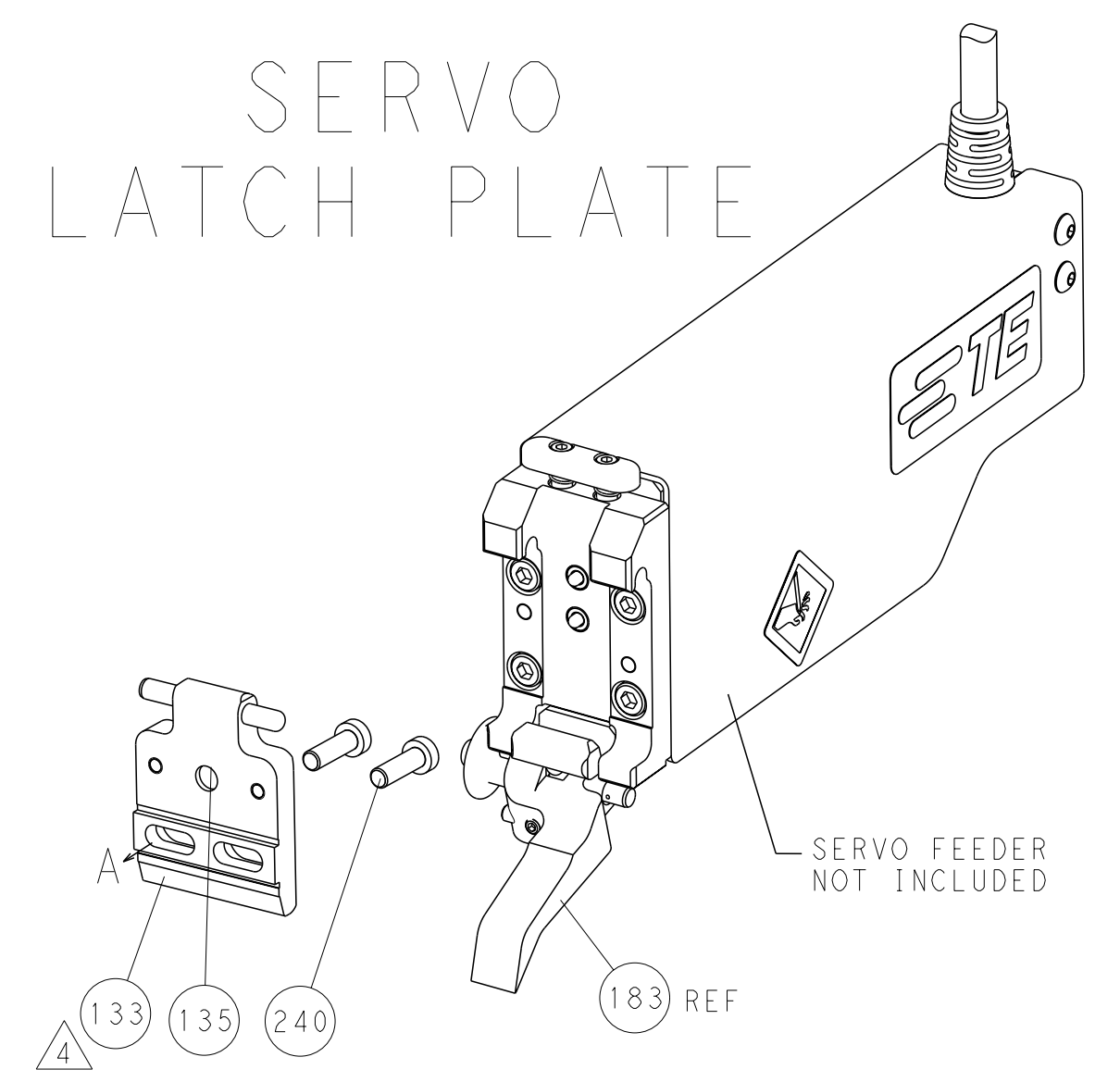

CAM POSITIONS

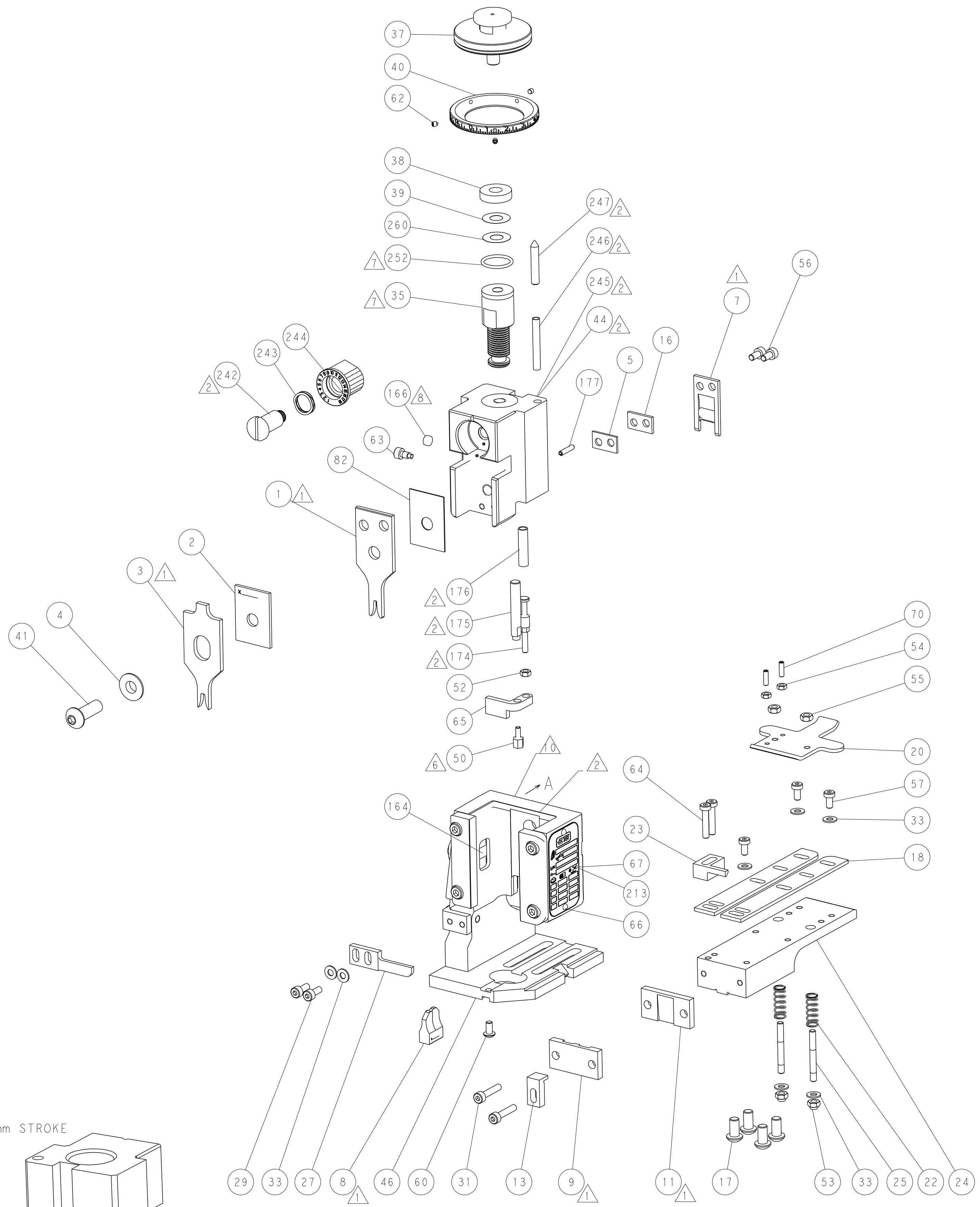
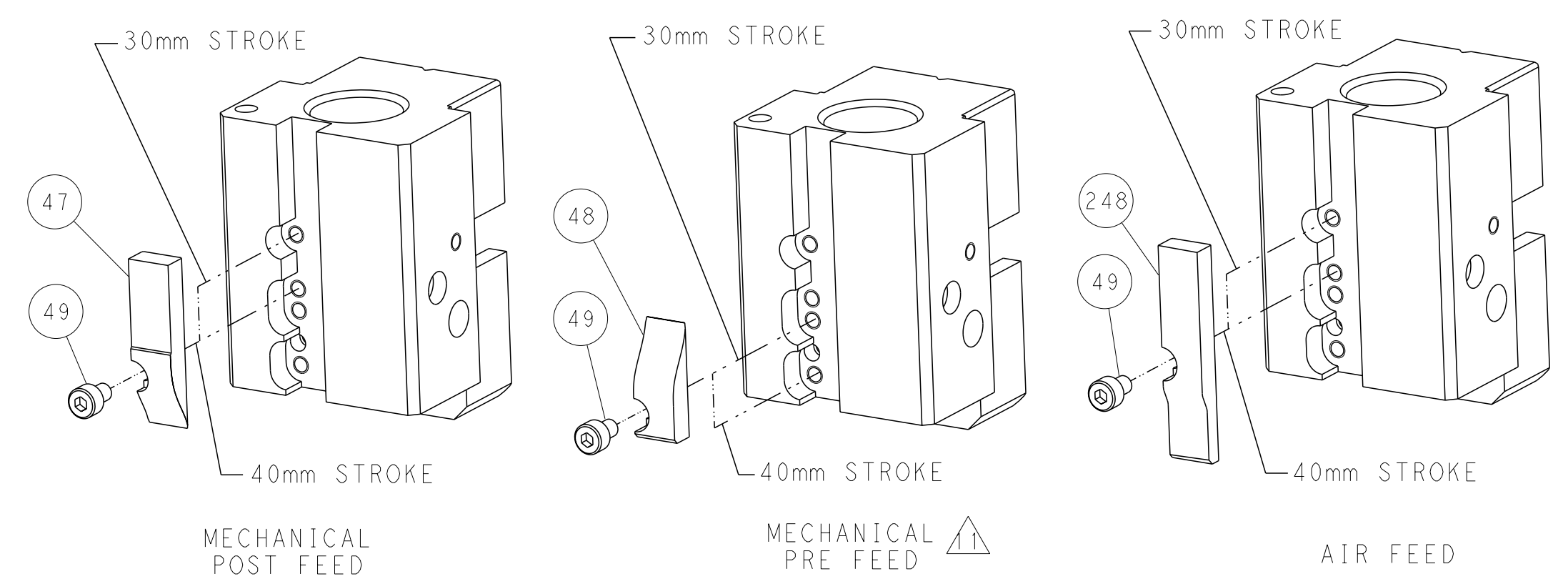

ATLANTIC VERSION
 Shown on sheets 1 of 4 & 2 of 4
 (Pacific version shown on sheets 3 of 4 & 4 of 4)

DIMENSIONS: mm 		TOLERANCES UNLESS OTHERWISE SPECIFIED: 9 PLC ±.5 1 PLC ±0.5 3 PLC ±0.13 5 PLC ±0.013 4 PLC ±0.001 ANGLES ±.1 FINISH		DWN: HOFFNER 30 JAN 2012 CHK: T. ELBIN 31 JAN 2012 APVD: T. ELBIN 31 JAN 2012 PRODUCT SPEC APPLICATION SPEC WEIGHT CUSTOMER ACCESSIBLE PRODUCTION DRAWING		NAME: Ocean End Feed Applicator SIZE: A1 CAGE CODE: 00779 DRAWING NO: C-2150239 SCALE: 1:1 SHEET: 2 OF 4 REV: A		RESTRICTED TO:	
--------------------	--	--	--	---	--	---	--	----------------	--

PACIFIC VERSION TERMINATOR INTERFACE ADAPTER	PART NUMBER	REVISION	DESCRIPTION	FEED TYPE	APPLICATOR STYLE CONVERSION CHART						
					CONVERT TO	PART NUMBERS REQUIRED					
					PNEUMATIC FEED	2119950-1	2119792-2	-	2119641-2	-	2063440-1
	2-2150239-1	A	FINE CRIMP HEIGHT ADJUST	MECHANICAL	SERVO LATCH PLATE	2119951-1	1901697-1	8-2150239-5	-	-	2168400-7 (QUANTITY 2)
					SMART APPLICATOR	2161326-1	-	8-2150239-4	-	-	-
					MECHANICAL FEED	2119949-1	2063961-1	5-18022-5	2119653-2	-	-
2-2150239-2	A	FINE CRIMP HEIGHT ADJUST	PNEUMATIC	SERVO LATCH PLATE	2119951-1	1901697-1	8-2150239-5	-	-	2168400-7 (QUANTITY 2)	
				SMART APPLICATOR	2161326-1	-	8-2150239-4	-	-	-	
				MECHANICAL FEED	2119949-1	2063961-1	5-18022-5	2119653-2	-	-	
2-2150239-5	A	FINE CRIMP HEIGHT ADJUST	SERVO LATCH PLATE	PNEUMATIC FEED	2119950-1	2119792-2	-	-	-	2063440-1	
				-	-	-	-	-	-	-	
2-2150239-7	A	FINE CRIMP HEIGHT ADJUST	NONE	-	-	-	-	-	-	-	
7-2150239-7	A	CRIMP TOOLING KIT	-	-	-	-	-	-	-	-	

APPLICATOR DATA		
CRIMP SIZE	TYPE	
WIRE 2.29 mm (.090)	F	
INSUL 3.30 mm (.130)	F	
APPL INSTRUCTIONS 408-10390		

TERMINAL DATA: TE TERMINAL		TE CRIMP SPECIFICATION	
TERMINAL NAME: RECEPTACLE, FASTON, .110 SERIES			
WIRE STRIP LENGTH	INSULATION DIAMETER RANGE		
2.00-3.00 mm (.079-.118 IN)	Ø2.79-4.32 mm (.110-.170 IN)		
TERMINAL APPLICATION SPECIFICATION	114-2065		
TERMINALS APPLIED			
TE TERMINAL	TE TERMINAL	TE TERMINAL	TE TERMINAL
1217345-1	1217345-2		

WIRE SIZE	CRIMP HEIGHT mm [INCH]	CRIMP HEIGHT REFERENCE SETTING
(2) 18 AWG	1.70 +/- 0.05 [.067 +/- .002]	9.1
16 AWG	1.60 +/- 0.05 [.063 +/- .002]	10.2
18 AWG	1.42 +/- 0.05 [.056 +/- .002]	12.0

- RECOMMENDED SPARE PARTS
- GREASE BEARING SURFACES LIGHTLY
- 3. LUBRICATE DAILY PER THE APPLICATOR INSTRUCTION SHEET SUPPLIED WITH THE APPLICATOR.
- APPLICATOR SPECIFIC DATA TO BE ENTERED INTO BLANK MEMORY CHIP AT ASSEMBLY. SEE BELOW FOR PART NUMBER:
 MECHANICAL FEED WITH "SMART APPLICATOR" CONVERSION: 8-2150239-4
 PNEUMATIC FEED WITH "SMART APPLICATOR" CONVERSION: 8-2150239-4
 SERVO FEED WITH "FINE CRIMP HEIGHT ADJUST": 8-2150239-5
- 5. ADJUSTMENT OF THE STRIPPER MAY BE REQUIRED WHEN MOVING THE APPLICATOR BETWEEN BENCH AND LEADMAKER APPLICATIONS.
- APPLY PART NUMBER 1-23419-5 LOCTITE TO THREADS OF ITEM 50.
- GREASE THREADS, GROOVE AND O-RING ON ITEMS 139 & 153.
- MAGNET, ITEM 166 MUST BE ORIENTED CORRECTLY IN ORDER TO PROPERLY ACTUATE THE COUNTER.
- CRIMP HEIGHT REFERENCE SETTING WAS THE SETTING USED WHEN THE APPLICATOR WAS QUALIFIED AT THE FACTORY. ADJUSTMENT MAY BE NECESSARY WHEN RUNNING APPLICATOR IN THE FIELD.
- SPARE FEED CAM STORAGE LOCATION REFER TO INSTRUCTION SHEET FOR ADDITIONAL INFORMATION.
- THE RECOMMENDED SET-UP FOR END FEED APPLICATORS IS POST-FEED WITH ITEM 2119653-1. THE APPLICATOR CAN BE CONFIGURED FOR PRE-FEED WITH ITEM 2119652-1 BUT MAY ENCOUNTER PROBLEMS WITH SOME APPLICATIONS. FEED ISSUES OR TERMINAL JAMMING MAY OCCUR IN THE PRE-FEED CONFIGURATION.

***WARNING**
 ON INSTALLATION, SET WIRE DISC, ITEM 40 TO LARGEST WIRE SIZE SETTING. USE OF SETTINGS BELOW MINIMUM REQUIRED CRIMP HEIGHT SETTING WILL CAUSE DAMAGE TO CRIMP TOOLING.

-77-27-25-22-21	PART NO	DESCRIPTION	ITEM NO
- 1 1 1 1 1	2119782-1	FINE ADJUST HEAD ASM, PACIFIC STYLE	251
- - - 1 -	2119640-1	PUSH ROD, AIR FEED	250
- - - 1 -	2079988-1	BUSHING, LCH5-12, MISUMI	249
- 1 1 1 1 1	1-22279-3	SPRING, COMPRESSION	246
- 1 1 1 1 1	2119082-9	CAM, SNAIL, INSULATION ADJUSTMENT	244
- 1 1 1 1 1	2079764-1	WASHER, WAVE SPRING, CREST-TO-CREST	243

PACIFIC VERSION
 Shown on sheets 3 of 4 & 4 of 4
 (Atlantic version shown on sheets 1 of 4 & 2 of 4)

SET UP GAUGE	LOC	DIST	REVISIONS			
2119599-2	A	66	REV	DATE	BY	APPD
			-	-	-	-
			-	-	-	-

REV	DATE	BY	APPD	DESCRIPTION	DATE	BY	APPD
- 1 1 1 1	2119083-1			RETAINER, INSULATION DIAL			242
- - 2 - -	2168400-7			SHCS, LOW HEAD, RoHS, M5 X 10			240
- - - 1 - 1	2119580-1			MECHANICAL FEED ASSEMBLY			239
- - - 1 -	2063440-1			AIR FEED MODULE			238
- - 1 - -	2119740-2			TAG, IDENTIFICATION			213
- 4 4 4 4	2079383-9			SCR, BHSC, RoHS (M6 X 20)			186
- - REF - -	1901697-1			FEED FINGER ASSEMBLY, EF			183
- 1 1 1 1	6-993111-6			PIN, SLOTTED SPRING 3.0 X 14.0			177
- 1 1 1 1	8-22280-7			SPRING, COMPRESSION			176
- 1 1 1 1	1752353-2			GUIDE PIN, HOLDDOWN			175
- 1 1 1 1	1901680-2			GUIDE PIN, HOLDDOWN			174
- - - 2 -	21045-3			RING, RETAIN, EXTERN, 3/16 CRESCENT			172
- 1 1 1 1	994969-1			MAGNET, RARE EARTH HIGH ENERGY			166
- REF REF REF REF	994970-2			COUNTER, MAGNETIC			164
- - - 1 -	240638-1			SPRING, FEED FINGER			163
- 1 1 1 1	8-21084-1			O-RING, .801 ID, .070 DIA. MAT.			153
- - - 1 -	2119641-2			FEED CAM, AIR FEED			152
- 1 1 1 1	2119798-2			DETENT PIN			145
- 1 1 1 1	2079383-8			SCR, BHSC, RoHS (M4 X 16)			144
- - - - 1	2119653-2			FEED CAM, POST FEED			142
- 1 1 1 1	2119655-6			APPLICATOR BASIC ASSEMBLY, EF			141
- 1 1 1 1	2119651-1			RAM, ASIAN STYLE, END FEED			140
- 1 1 1 1	2119092-2			BOLT, ADJUSTMENT			139
- - - 1 -	3-23627-7			PIN, RETAIN, GRVD, 3/16 X .854			137
- - REF - -	SEE NOTE 4			MEMORY CHIP, PROGRAMMED			135
- - 1 - -	1633743-1			SERVO FEED LATCH ASM			133
- 1 1 1 1	455888-5			SPACER, CRIMPER			82
- 1 1 1 1	2119956-2			DOCUMENTATION PACKAGE			71
- 2 2 2 2	2-18032-2			SCR, SET, FLT POINT M3 X 10.0			70
- 1 - 1 1	2119740-1			TAG, IDENTIFICATION			67
- 2 2 2 2	2168078-1			SCREW, DRIVE, RH, RoHS			66
- 1 1 1 1	1901681-5			HOLDDOWN, TERMINAL			65
- 2 2 2 2	2168400-5			SHCS, LOW HEAD, RoHS, M4 X 20			64
- 1 1 1 1	2119793-1			LIMITER, ADJUSTMENT BOLT			63
- 3 3 3 3	992763-5			SCR, SET, SOC, CONE POINT, M3 X 4.0			62
- - - - 1	5-18022-5			SCR, HEX HD CAP, M4 X 6.0			59
- - - - 1	2063961-1			FEED FINGER			58
- 3 3 3 3	2168400-4			SHCS, LOW HEAD, RoHS, M4 X 8			57
- 2 2 2 2	2168083-2			SCR, SKT HD CAP, RoHS, M4 X 8.0			56
- 2 2 2 2	5018030-2			NUT, HEX, REG, RoHS, M4			55
- 2 2 2 2	5018030-1			NUT, HEX, REG, RoHS, M3			54
- 2 2 2 2	986965-8			NUT, LOCK, HEX, TORQUE (M4)			53
- 1 1 1 1	1-5018030-0			NUT, HEX, REG, RoHS, M3.5			52
- - - 1 -	2119792-2			PAWL, EF, AIR			51
- 1 1 1 1	1752354-8			STANDOFF, HOLD-DOWN			50
- - - 1 2	18023-9			SCR, SKT HD CAP M4 X 6.0			49
- - - - 1	2119652-1			FEED CAM, PRE FEED			48
- 1 1 1 1	2079383-7			SCR, BHSC, RoHS (M8 X 25)			41
- 1 1 1 1	2119645-1			DISC, NUMBERED FA WIRE ADJUSTMENT			40
- 1 1 1 1	2119957-1			APPLICATOR SHIM PACK			39
- 1 1 1 1	2119644-2			RAM WASHER, PRECISION			38
- 7 7 7 7	1-18028-2			WASHER, FLAT, REG M4			33
- 2 2 2 2	2168083-9			SCR, SKT HD CAP, RoHS, M4 X 20			31
- 2 2 2 2	1-2168083-0			SCR, SKT HD CAP, RoHS, M4 X 10			29
- 1 1 1 1	240639-1			STRIPPER (MACHINING)			27
- 2 2 2 2	1320906-1			STUD, THREADED			25
- 1 1 1 1	1752371-5			PLATE, STRIP GUIDE			24
- 1 1 1 1	240825-5			PLATE, STRIP HOLD DOWN			23
- 2 2 2 2	1-22281-2			SPRING, COMPRESSION			22
- 1 1 1 1	1752373-1			DRAG			20
- 2 2 2 2	1-1901259-0			GUIDE, LOWER STRIP			18
- 1 1 1 1	1-240641-3			SPACER			16
- 1 1 1 1	1752360-1			SPACER, HOLD-DOWN			13
- 1 1 1 1	1-240644-7			PLATE, REAR SHEAR			11
- - - - -	-			-			10
- 1 1 1 1	5-690482-4			PLATE, FRONT SHEAR			9
1 1 1 1	6-1633383-0			ANVIL, COMBINATION			8
- 1 1 1 1	690474-6			BLADE, SLUG			7
- 1 1 1 1	5-240641-4			SPACER			5
- 1 1 1 1	238009-1			BLOCK, FL CRIMPER SPACER			4
1 1 1 1	2-1633961-6			CRIMPER, INSULATION F PREMIUM			3
- 1 1 1 1	1-455888-8			SPACER, CRIMPER			2
1 1 1 1	4-456406-1			CRIMPER, WIRE PREMIUM			1

DIMENSIONS: mm		TOLERANCES UNLESS OTHERWISE SPECIFIED:		DWG: HOFFNER 30JAN2012		CHK: 31JAN2012		APD: 31JAN2012		NAME: I. ELBIN		TE Connectivity Harrisburg, PA 17105-3608	
9 PLC ±.5		1 PLC ±0.13		5 PLC ±0.013		4 PLC ±0.001		ANGLES ±.0001		FINISH		SIZE: CAGE CODE: DRAWING NO: RESTRICTED TO	
MATERIAL		WEIGHT		A1 00779		C=2150239		CUSTOMER ACCESSIBLE PRODUCTION DRAWING		SCALE: 1:1		SHEET 3 OF 4 REV A	

LOC	DIST	REV	DATE	BY	APPD
A	66				
REVISIONS			DESCRIPTION	DATE	DWN
-			SEE SHEET 1	-	-

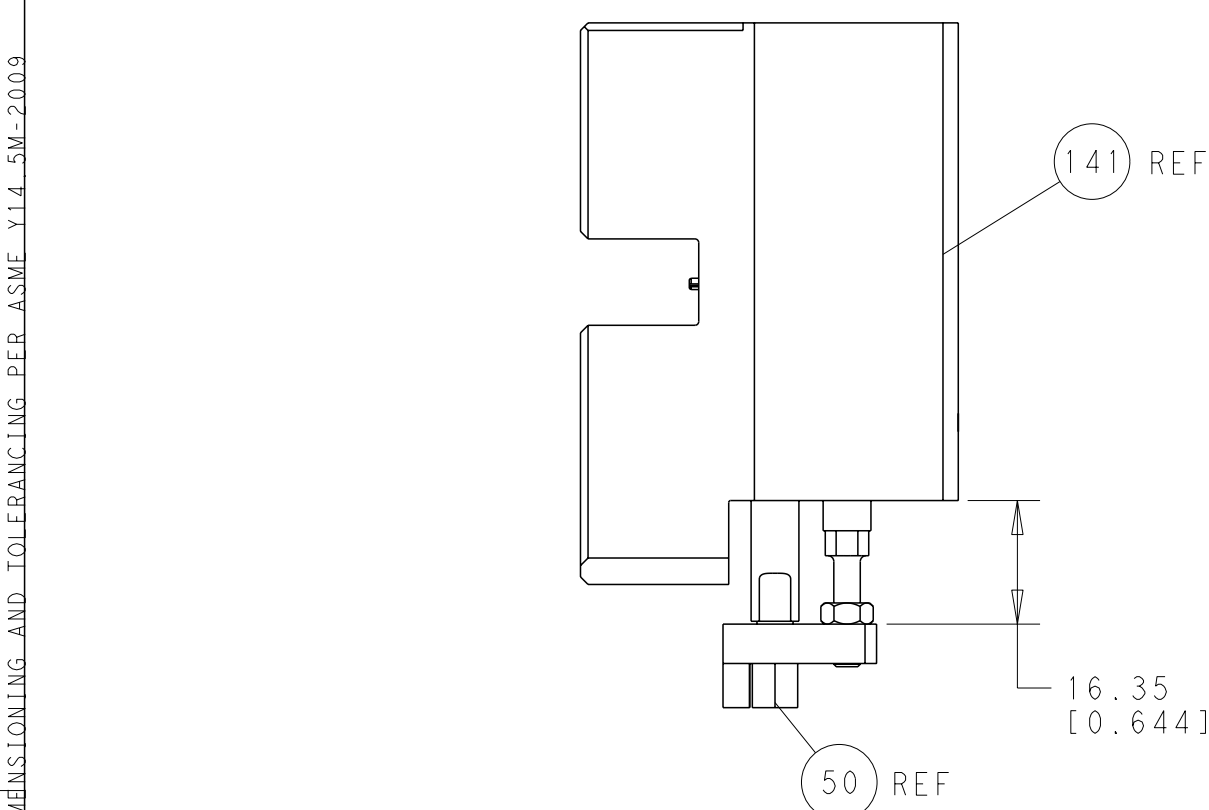

HOLDDOWN SET-UP

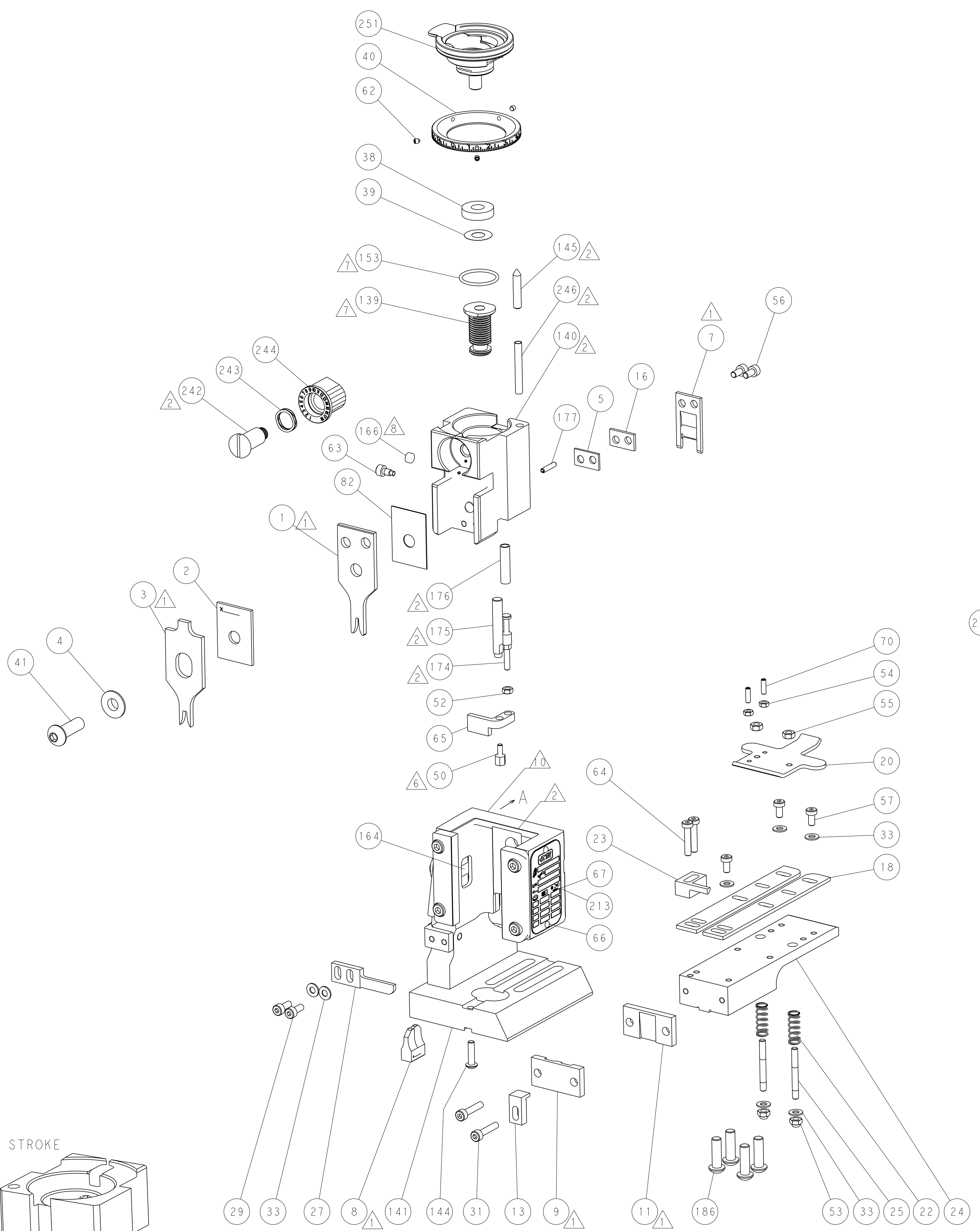

FEED TYPE
MECHANICAL

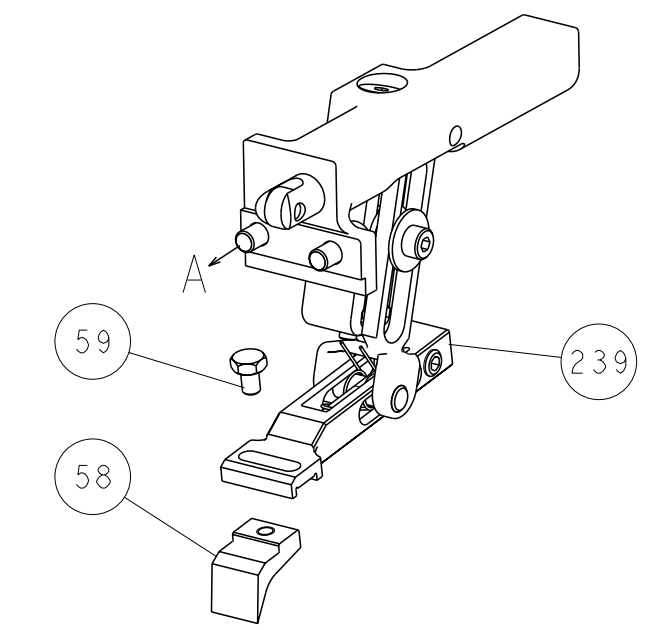

PNEUMATIC

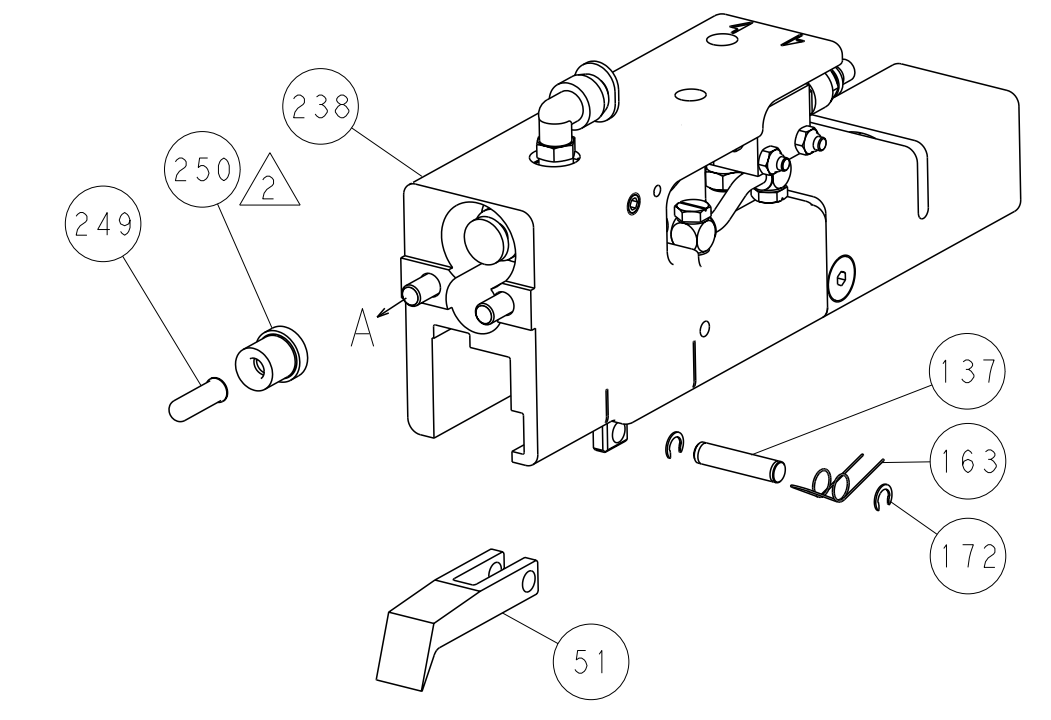

SERVO
LATCH PLATE

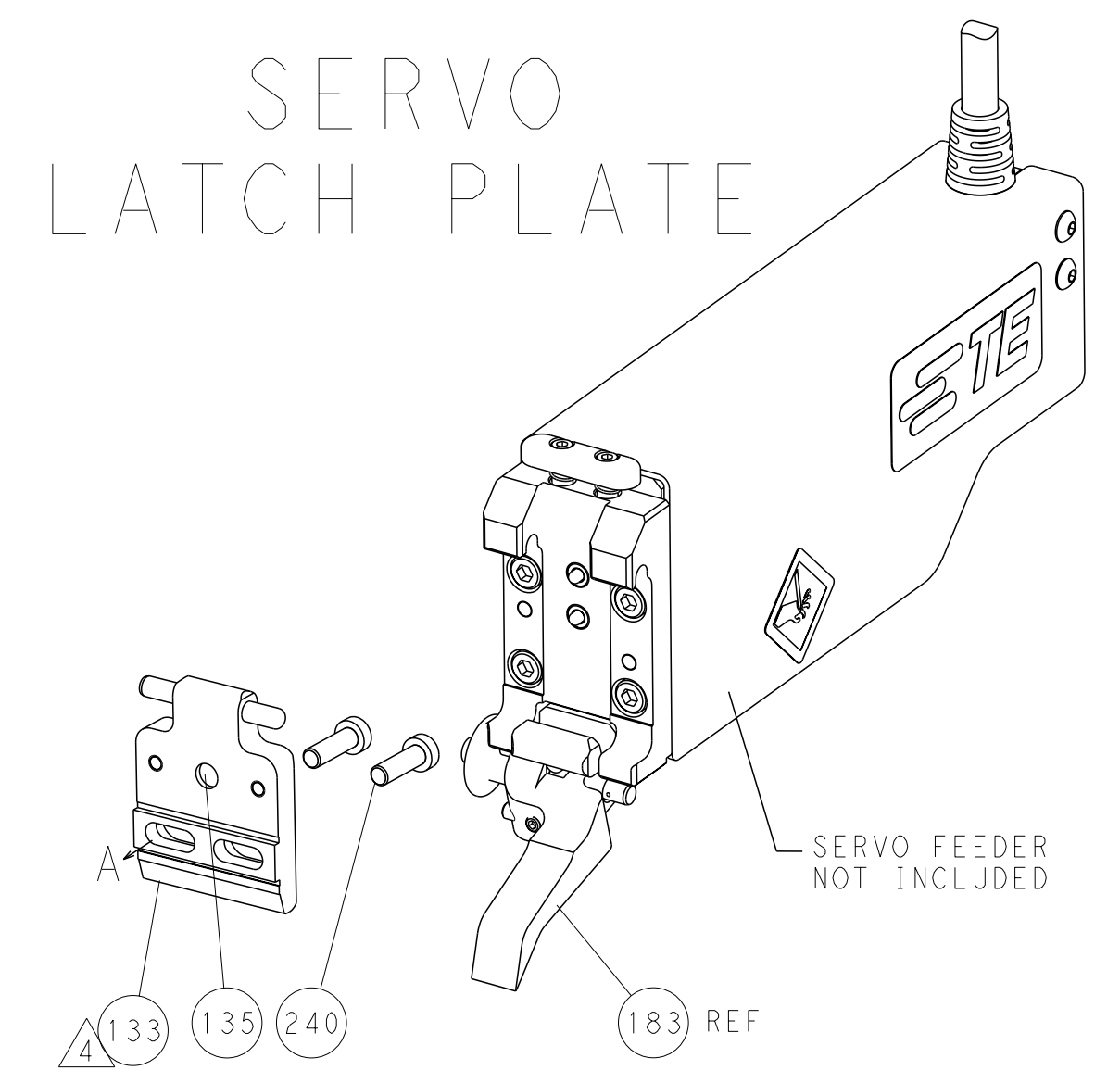

CAM POSITIONS

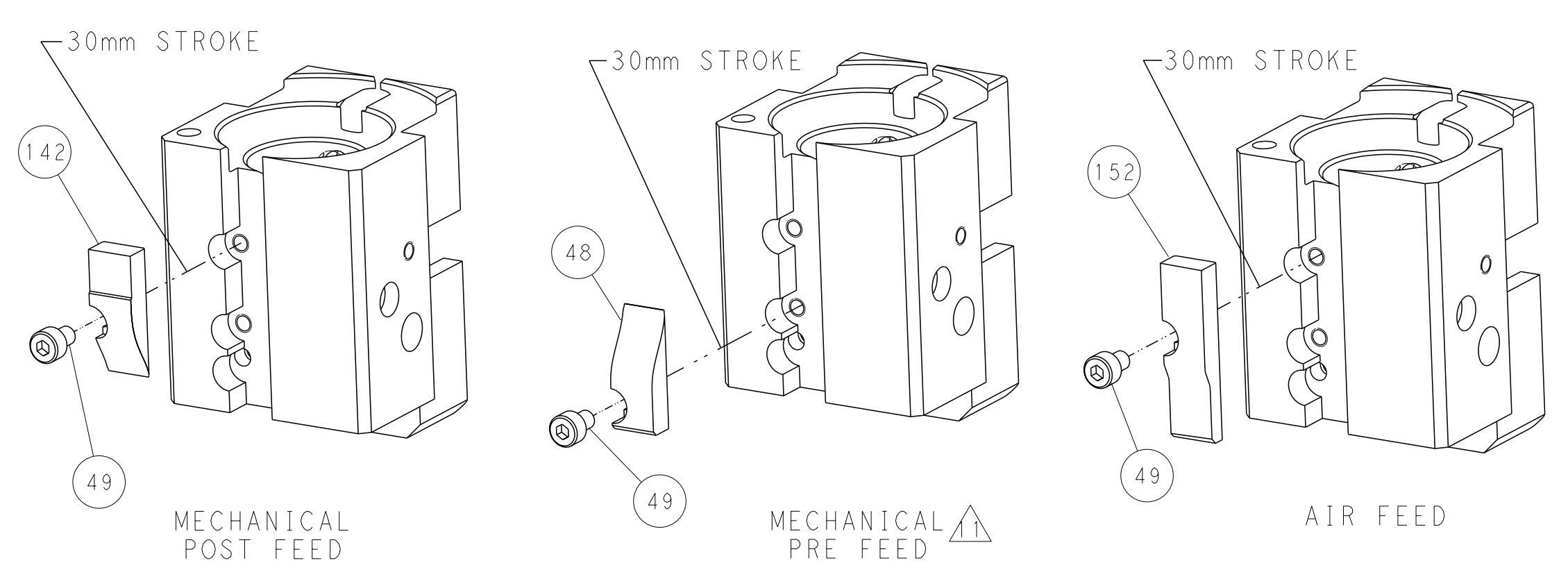

PACIFIC VERSION
 Shown on sheets 3 of 4 & 4 of 4
 (Atlantic version shown on sheets 1 of 4 & 2 of 4)

DIMENSIONS:		TOLERANCES UNLESS OTHERWISE SPECIFIED:		DWN: HOFFNER 30JAN2012		TE Connectivity	
mm		9 PLC ±0.5		CHK: T. ELBIN 31JAN2012		Harrisburg, PA 17105-3608	
Ø		1 PLC ±0.13		APPD: T. ELBIN 31JAN2012		NAME: Ocean End Feed Applicator	
MATERIAL:		2 PLC ±0.013		PRODUCT SPEC:		SIZE: CAGE CODE: DRAWING NO:	
		3 PLC ±0.013		APPLICATION SPEC:		A11 00779 C-2150239	
		4 PLC ±0.001		WEIGHT:		SCALE: 1:1 SHEET 4 OF 4 REV A	
		ANGLES FINISH:		CUSTOMER ACCESSIBLE PRODUCTION DRAWING		RESTRICTED TO:	