



**austriamicrosystems AG**

**is now**

**ams AG**

The technical content of this austriamicrosystems datasheet is still valid.

**Contact information:**

**Headquarters:**

ams AG  
Tobelbaderstrasse 30  
8141 Unterpremstaetten, Austria  
Tel: +43 (0) 3136 500 0  
e-Mail: [ams\\_sales@ams.com](mailto:ams_sales@ams.com)

Please visit our website at [www.ams.com](http://www.ams.com)

## AS3713

### Quad Buck High Current PMIC without Charger

#### 1 General Description

The AS3713 is a compact System PMU with integrated battery charger and back light driver.

The device offers advanced power management functions. All necessary ICs and peripherals in a battery powered mobile device are supplied by the AS3713. It features 3 DCDC buck converters as well as 8 low noise LDOs. The different regulated supply voltages are programmable via the serial control interface. 4MHz operation with 1uH coils are reducing cost and PCB space.

AS3713 further features a DCDC buck controller which is ideal to support processor core currents up to 3A.

The two step-up converter generate voltages for e.g.the backlight, classD amplifier, USB host support or LCD display supply. Both constant voltage (for e.g. OLED supply) as well as constant current (white LED backlight) operations with three current sinks are possible. An internal voltage protection is limiting the output voltage in the case of external component failures.

The single supply voltage may vary from 2.7V to 5.5V.

#### 2 Key Features

##### Voltage Generation

- 3 DCDC step down regulators (2-4MHz)
  - DVM (0.6V-3.3V; 1x 1.2-1.5A, 2x 0.7-1A)
  - 60µA quiescent current
  - 2A with combined DCDC 2 & 3
- DCDC step down controller
  - DVM (0.6V-3.3V; 2-3A)
- 2 analog low noise LDOs, 6 digital LDOs
  - 2x 1.2-3-3V, 6x 0.9-3.3V; 150-300mA
  - 30µA quiescent current (low power mode)
- 1 ultra low power always on LDO 2.5V, 10mA
- Power supply supervision
- 4sec and 8sec emergency shut-down
- Stand-by function with voltage selection

##### HV Backlight Driver

- 2x step up with external transistor
  - e.g. 0.5-1A@5V; 40mA@50V
- Voltage control mode and over-voltage protection
- 3 programmable current sinks (max. 40mA)
- Possible external PWM dimming input (DLS, CABC)

##### Supervisor

- Automatic battery monitoring with interrupt generation and selectable warning level
- Automatic temperature monitoring with interrupt generation and selectable warning and shutdown levels

##### Real Time Clock

- Ultra low power 32kHz oscillator
- Sec and minute counter, auto wake-up
- Programmable alarm
- Repeating alarm (seconds, minutes, 2 minutes, or 8 minutes)
- 32kHz clock output to peripheral
- <1µA total power consumption

##### General Purpose IOs

- 10-bit general purpose ADC input
- Wake-up/sleep and DVM input
- PWM (DLS, CABC) dimming input
- Status output for: low battery, power good and step-up over-current
- Q32k clock output
- Interrupt output
- PWM output
- Step-up feedback input

**OTP programmable BOOT Sequence**

- Programmable regulator default voltages
- Programmable start-up sequence

**General Purpose ADC**

- 10-bit resolution
- Several internal / external sources
  - VUSB, VSUP, CHGIN, VBAT
  - GPIOx, CURRx
  - XOUT32K, SENSEN\_SU1, LX\_SD4
  - Chip temperature

**Control Interface**

- I2C control lines, including watchdog
- ON input
- Bidirectional reset, with selectable delay
- Ultra low power standby mode

**Power-On Reset Circuit**

**Packaging**

QFN56 7x7mm 0.4mm pitch

**3 Application**

The device is suitable for Set-top Boxes, Portable Media Players, Portable Navigation Devices, E-Books, Mobile Internet Devices, and Tablet PCs.

Figure 1. AS3713 Block Diagram

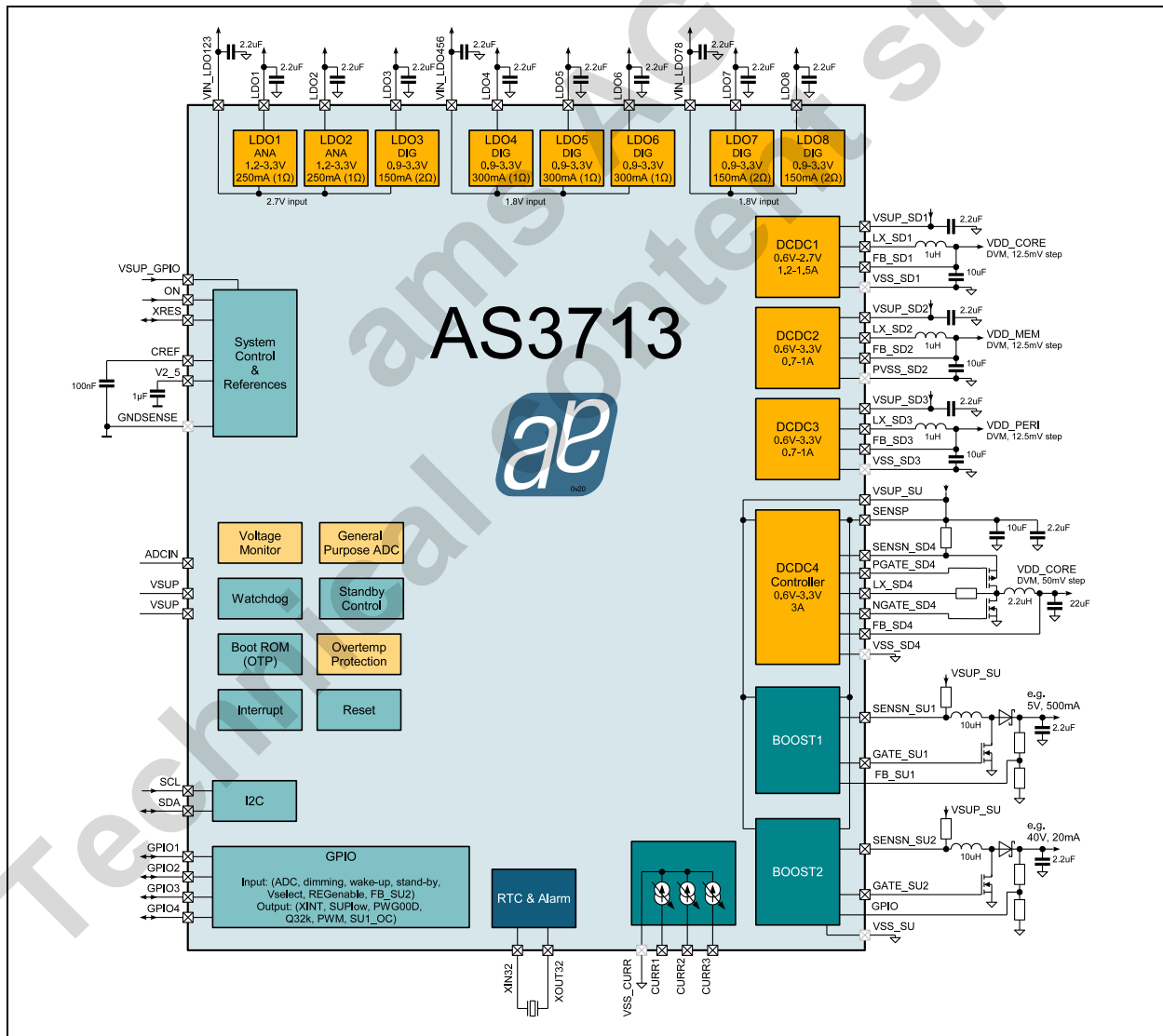

## Contents

1	General Description .....	1
2	Key Features .....	1
3	Application .....	2
4	Pin Assignments .....	4
4.1	Pin Descriptions .....	4
5	Absolute Maximum Ratings .....	7
6	Electrical Characteristics .....	8
7	Typical Operating Characteristics .....	9
8	Detailed Description - Power Management Functions .....	10
8.1	DCDC Step-Down Converter .....	10
8.2	DCDC Step-Down Controller .....	16
8.3	Analog LDO Regulators .....	19
8.4	Digital LDO Regulators .....	21
8.5	Low power LDO V2_5 Regulators .....	23
8.6	DCDC Step-Up Converter .....	24
8.7	Current Sinks .....	30
9	Detailed Description - System Functions .....	31
9.1	Start-up .....	31
9.2	Reset .....	33
9.3	Stand-by .....	35
9.4	Internal References .....	36
9.5	GPIO Pins .....	37
9.6	Supervisor .....	40
9.7	Watchdog .....	41
9.8	Interrupt Generation .....	42
9.9	10-Bit ADC .....	43
9.10	Real Time Clock .....	45
9.11	2-Wire-Serial Control Interface .....	46
10	Register Overview .....	48
11	Application Information .....	82
12	Package Drawings and Markings .....	85
13	Ordering Information .....	88

## 4 Pin Assignments

Figure 2. Pin Assignments (Top View)

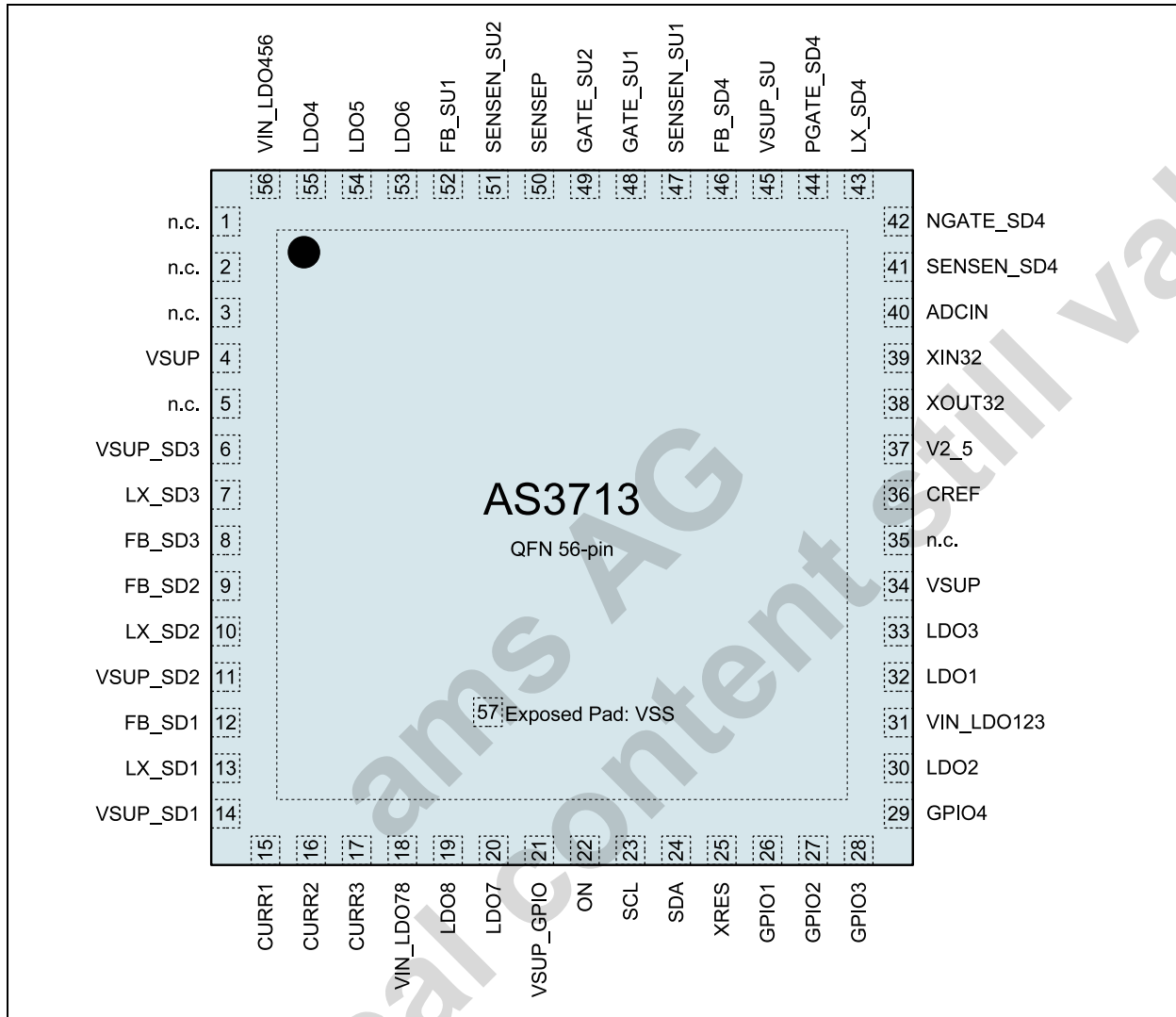

## 4.1 Pin Descriptions

Table 1. Pin Descriptions

Pin Number	Pin Name AS3713	Pin Type	Description	if not used
1	n.c.	-	leave unconnected	open
2	n.c.	-	leave unconnected	open
3	n.c.	-	leave unconnected	open
4	VSUP	SUP IO	connect to VSUPx	always needed
5	n.c.	-	leave unconnected	open
6	VSUP_SD3	SUP IN	DCDC Step Down 3 Pos. Supply Terminal	always needed
7	LX_SD3	DIG OUT	DCDC Step Down 3 Switch Output to Coil	open
8	FB_SD3	ANA IN	DCDC Step Down 3 Feedback Pin	open
9	FB_SD2	ANA IN	DCDC Step Down 2 Feedback Pin	open
10	LX_SD2	DIG OUT	DCDC Step Down 2 Switch Output to Coil	open
11	VSUP_SD2	SUP IN	DCDC Step Down 2 Pos. Supply Terminal	always needed
12	FB_SD1	ANA IN	DCDC Step Down 1 Feedback Pin	open
13	LX_SD1	DIG OUT	DCDC Step Down 1 Switch Output to Coil	open
14	VSUP_SD1	SUP IN	DCDC Step Down 1 Pos. Supply Terminal	always needed
15	CURR1	ANA IO	Load Current Sink 1 Terminal	open
16	CURR2	ANA IO	Load Current Sink 2 Terminal	open
17	CURR3	ANA IO	Load Current Sink 3 Terminal	open
18	VINLDO78	SUP IN	LDO 7 & 8 Positive Supply Terminal, connect to VSUP	always needed
19	LDO8	ANA OUT	LDO8 Output	open
20	LDO7	ANA OUT	LDO7 Output	open
21	VSUP_GPIO	SUP IN	GPIO Positive Supply Terminal, connect to VSUP	always needed
22	ON	DIG IN	Power Up Input	open
23	SCL	DIG IN	2-wire Serial IF Clock Input	open
24	SDA	DIG IO	2-wire Serial IF Data I/O	open
25	XRES	DIG IO	Reset IO	open
26	GPIO1	ANA IO	General Purpose IO 1	open
27	GPIO2	ANA IO	General Purpose IO 2	open
28	GPIO3	ANA IO	General Purpose IO 3	open
29	GPIO4	ANA IO	General Purpose IO 4	open
30	LDO2	ANA OUT	LDO2 Output	open
31	VINLDO123	SUP IN	LDO 1, 2 & 3 Positive Supply Terminal, connect to VSUP	always needed
32	LDO1	ANA OUT	LDO1 Output	open
33	LDO3	ANA OUT	LDO3 Output	open
34	VSUP	SUP IO	connect to VSUPx	always needed
35	n.c.	-	leave unconnected	open
36	CREF	ANA IO	Reference Bypass Capacitor Terminal	always needed

Table 1. Pin Descriptions

Pin Number	Pin Name AS3713	Pin Type	Description	if not used
37	V2_5	ANA OUT	Internal 2.5V Regulator Supply Output	always needed
38	XOUT32	ANA OUT	RTC 32kHz Crystal Drive Terminal	open
39	XIN32	ANA IN	RTC 32kHz Crystal Feedback Terminal	open
40	ADCIN	ANAIO	ADC10 input	open
41	SENSEN_SD4	ANA IN	DCDC Step Down 4 Negative Sense Resistor Input	open
42	NGATE_SD4	ANA OUT	DCDC Step Down 4 ext. NMOS Gate Driver Output	open
43	LX_SD4	ANAIN	DCDC Step Down 4 Sense Input	open
44	PGATE_SD4	ANA OUT	DCDC Step Down 4 ext. PMOS Gate Driver Output	open
45	VSUP_SU	SUP IN	DCDC Step Down 4 Positive Supply Terminal, connect to VSUP	always needed
46	FB_SD4	ANA IN	DCDC Step Down 4 Feedback Pin	open
47	SENSEN_SU1	ANA IN	DCDC Step Up 1 Negative Sense Resistor Input	open
48	GATE_SU1	ANA OUT	DCDC Step Up 1 ext. NMOS Gate Driver Output	open
49	GATE_SU2	ANA OUT	DCDC Step Up 2 ext. NMOS Gate Driver Output	open
50	SENSEP	ANA IN	DCDC Step Up 1, 2 & Positive Sense Resistor Input	open
51	SENSEN_SU2	ANA IN	DCDC Step Up 2 Negative Sense Resistor Input	open
52	FB_SU1	ANA IN	DCDC Step Up 1 Feedback Pin	open
53	LDO6	ANA OUT	LDO6 Output	open
54	LDO5	ANA OUT	LDO5 Output	open
55	LDO4	ANA OUT	LDO4 Output	open
56	LDO456	SUP IN	LDO 4, 5 & 6 Positive Supply Terminal, connect to VSUP	always needed

## 5 Absolute Maximum Ratings

Stresses beyond those listed in [Table 2](#) may cause permanent damage to the device. These are stress ratings only, and functional operation of the device at these or any other conditions beyond those indicated in [Electrical Characteristics on page 8](#) is not implied. Exposure to absolute maximum rating conditions for extended periods may affect device reliability.

Table 2. Absolute Maximum Ratings

Symbol	Parameter	Min	Max	Unit	Comments
<b>Electrical Parameters</b>					
	5V pins	-0.5	7.0	V	Applicable for pins VSUP, VSUP_SD1/2/3, VSUP_SU, VSUP_GPIO, VIN_LDO123/456/78, GPIO1/2/3/4, GATE_SU1/2, NGATE_SD4, PGATE_SD4, FB_SU1, SENSEP, SENSEN_SU1/2, SENSEN_SD4, CHGIN, VBAT, EXTBATSW, LDO1/2/3/4/5/6/7/8, FB_SD1/2/3/4, LX_SD1/2/3/4, XRES, SCL, SDA
	3V pins	-0.5	5.0	V	Applicable for pins V2_5, CREF, ON, ADCIN, XIN32, XOUT32
	30V pins	-0.5	32	V	Applicable for pin VUSB, XOFF, CURR1/2/3
	Input Current (latch-up immunity)	-100	100	mA	Norm: JEDEC JESD78
<b>Continuous Power Dissipation (T<sub>A</sub> = +70°C)</b>					
P <sub>T</sub>	Continuous power dissipation		1.8	W	P <sub>T</sub> <sup>1</sup> for QFN56 package (R <sub>TH</sub> ~ 30K/W)
<b>Electrostatic Discharge</b>					
	Electrostatic Discharge HBM		±1.5	kV	Norm: JEDEC JESD22-A114F
<b>Temperature Ranges and Storage Conditions</b>					
T <sub>AMB</sub>	Operating Temperature	-40	+85	°C	
T <sub>J</sub>	Junction Temperature		+125	°C	
	Storage Temperature Range	-55	+150	°C	
	Humidity non-condensing	5	85	%	
<b>Temperature (soldering)</b>					
T <sub>BODY</sub>	Package Body Temperature		260	°C	Norm IPC/JEDEC J-STD-020 <sup>2</sup> The lead finish for Pb-free leaded packages is matte tin (100% Sn)
	Moisture Sensitive Level		3		Represents a max. floor life time of 168h

1. Depending on actual PCB layout and PCB used
2. The reflow peak soldering temperature (body temperature) is specified according IPC/JEDEC J-STD-020 "Moisture/Reflow Sensitivity Classification for Nonhermetic Solid State Surface Mount Devices"



## 6 Electrical Characteristics

VSUPx=+2.7V...+5.5V, T<sub>A</sub>=-40°C...+85°C. Typical values are at VSUPx=+3.6V, T<sub>A</sub>=+25°C, unless otherwise specified.

The parameters with min and max values are guaranteed with production tests or SQC (Statistical Quality Control) methods.

Table 3. Electrical Characteristics

Symbol	Parameter	Condition	Min	Typ	Max	Unit
VSUPx	Supply Voltage VSUP_x		2.7	3.6	5.5	V
VINLDO123	Supply Voltage for LDO 1, 2 & 3		2.7	3.6	5.5	V
VINLDO456	Supply Voltage for LDO 4, 5 & 6		1.8	3.6	5.5	V
VINLDO78	Supply Voltage for LDO 7 & 8		1.8	3.6	5.5	V
V2_5	Voltage on Pin V2_5		2.4	2.5	2.6	V
I <sub>low_power</sub>	Low Power current	@ VSUPx = 4.2V		220		μA
I <sub>power_off</sub>	Power-Off current	All regulators off V2_5 on		10		μA

## 7 Typical Operating Characteristics

please see operating characteristics in the block description chapters.

ams AG  
Technical content still valid

## 8 Detailed Description - Power Management Functions

### 8.1 DCDC Step-Down Converter

#### 8.1.1 General Description

The step-down converter is a high efficiency fixed frequency current mode regulator. By using low resistance internal PMOS and NMOS switches efficiency up to 95% can be achieved. The fast switching frequency allows using small inductors, without increasing the current ripple. The unique feedback and regulation circuit guarantees optimum load and line regulation over the whole output voltage range, up to an output current of 1A (SD2, SD3) and 1.5A for SD1, with an output capacitor of only 10 $\mu$ F. The implemented current limitation protects the DCDC and the coil during overload condition.

Figure 3. Step Down DC/DC Converter Block diagram

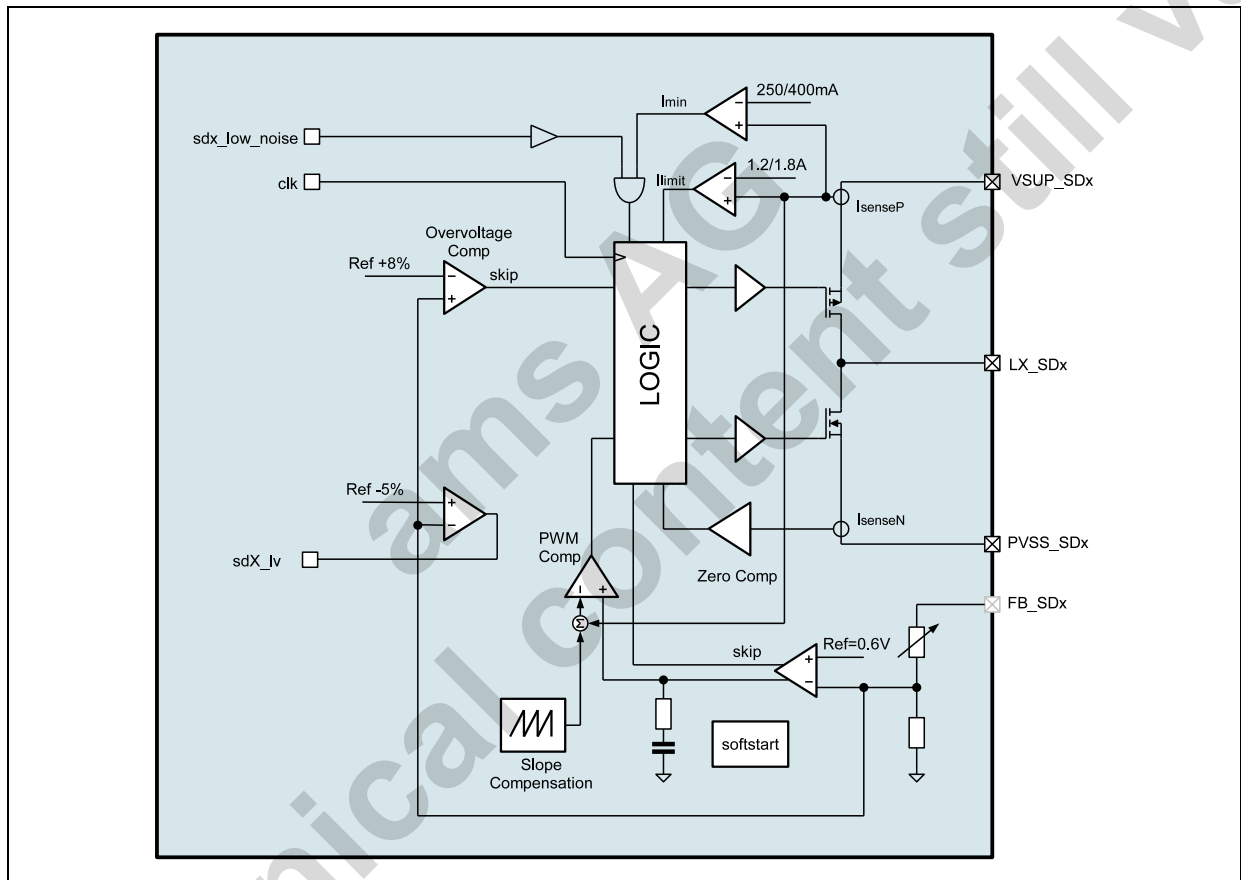

#### 8.1.2 Mode Settings

*Low ripple, low noise operation:*

Bit settings: sdx\_low\_noise=1

In this mode there is no minimum coil current necessary before switching off the PMOS. As long as the load current is superior to the ripple current the device operates in continuous mode. When the load current gets lower, the discontinuous mode is triggered. As result, the auto-zero comparator stops the NMOS conduction to avoid load discharger and the duty cycle is reduced down to  $t_{min\_on}$  to keep the regulation loop stable. This results in a very low ripple and noise, but decreased efficiency, at light loads, especially at low input to output voltage differences.

Only in the case the load current gets so small that less than the minimum on-time of the PMOS would be needed to keep the loop in regulation the regulator will enter low power mode operation. The crossover point is about 15mA for  $V_{in}=3V$ ,  $V_{out}=1.2V$ , 1 $\mu$ H, 4MHz.

Figure 4. DCDC Buck with enabled low noise mode

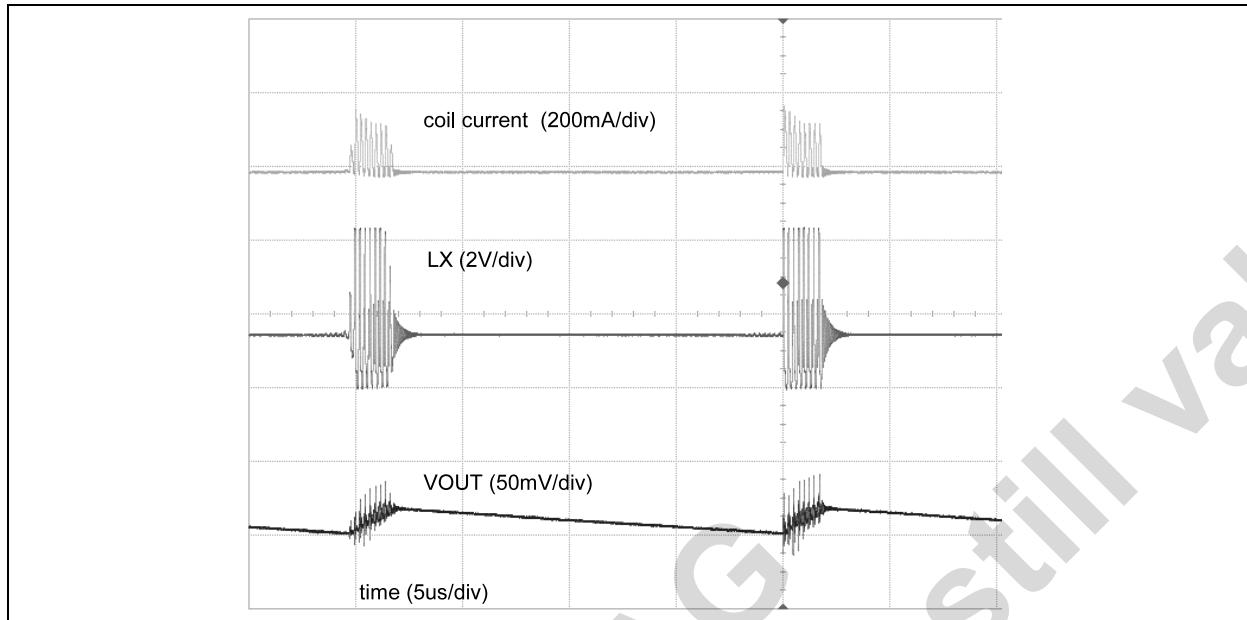
*High efficiency operation (default setting):*

Bit settings: sdX\_low\_noise=0

In this mode there is a minimum coil current necessary before switching off the PMOS. As a result there are less pulses necessary at low output loads, and therefore the efficiency at low output load is increased. As drawback this mode increases the ripple up to a higher output currents.

The crossover point to low power mode is already reached at reasonable high output currents. (e.g. @110mA for  $V_{in}=3V$ ,  $V_{out}=1.2V$ , 1uH, 4MHz)

Figure 5. DCDC Buck with disabled low noise mode

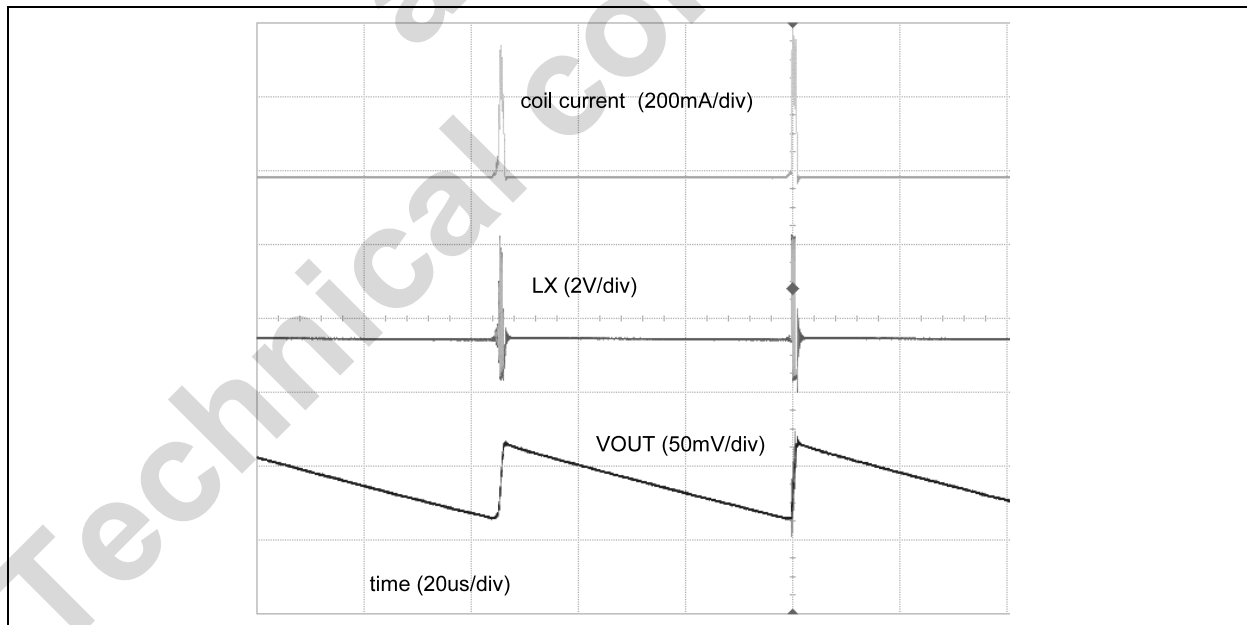

It's possible to switch between these two modes during operation:

### Low power mode operation (automatically controlled):

As soon as the output voltage stays above the desired target value for a certain time, some internal blocks will be powered down leaving the output floating to lower the power consumption. Normal operation starts as soon as the output drops below the target value for a similar amount of time. To minimize the accuracy error some internal circuits are kept powered to assure a minimized output voltage ripple.

Two addition guard bands, based on comparators, are set at +/-5% of the target value to react quickly on large over/undershoots by immediately turning on the output drivers without the normal time delays. This ensures a minimized ripple also in very extreme load conditions.

### DVM (Dynamic Voltage Management)

To minimize the over-/undershoot during a change of the output voltage, the DVM can be enabled. With DVM the output voltage will ramp up/down with a selectable slope after the new value was written to the registers. Without DVM the slew rate of the output voltage is only determined by external components like the coil and load capacitor as well as the load current.

DVM can be selected for all step-down converters, but only for one at a time. (see `sd_dvm_select` and `dvm_time` description)

### Fast Regulation Mode

This mode can be used to react faster on sudden load changes and thus minimize the over-/undershoot of the output voltage. This mode needs an 22uF output capacitor instead the 10uF one to guarantee the stability of the regulator. the mode is enabled by setting `sdX_fast = 1`.

### Selectable Frequency Operation

Especially for very low load conditions, e.g. during a sleep mode of a processor, the switching frequency can be reduced to achieve a higher efficiency. The frequency for SD1, SD2 and SD3 can be set to 2, 3 or 4MHz. This mode is selected by setting `sdX_freq` and `sdX_fsel` to the appropriate values.

### 100% PMOS ON Mode for Low Dropout Regulation

For low input to output voltage difference the DCDC converter can use 100% duty cycle for the PMOS transistor, which is then in LDO mode.

## 8.1.3 Step-Down Converter Configuration Modes

The step down DCDC converters have two configuration modes to deliver different output currents for the applications. The operating mode is selected by setting the bit `sd3_slave` (the default is set by the Boot-OTP).

Figure 6. DC/DC step-down SD1, SD2, SD3 Normal Operating Mode; `sd3_slave = 0`

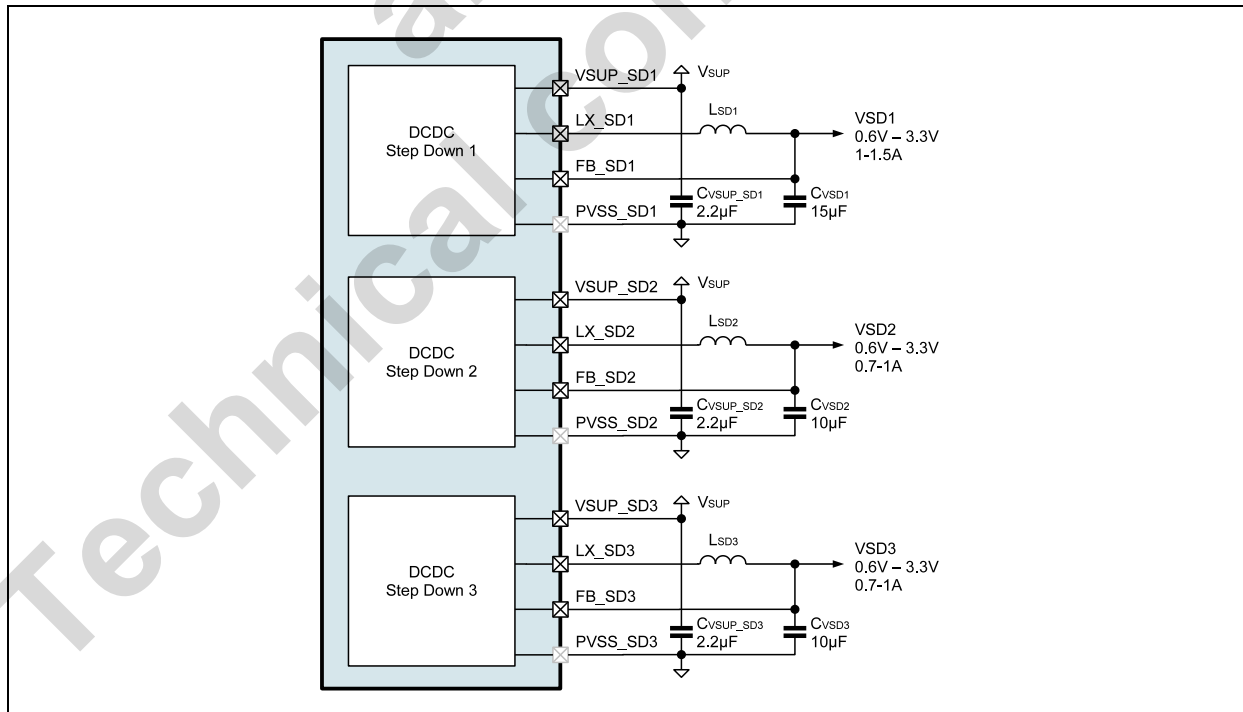
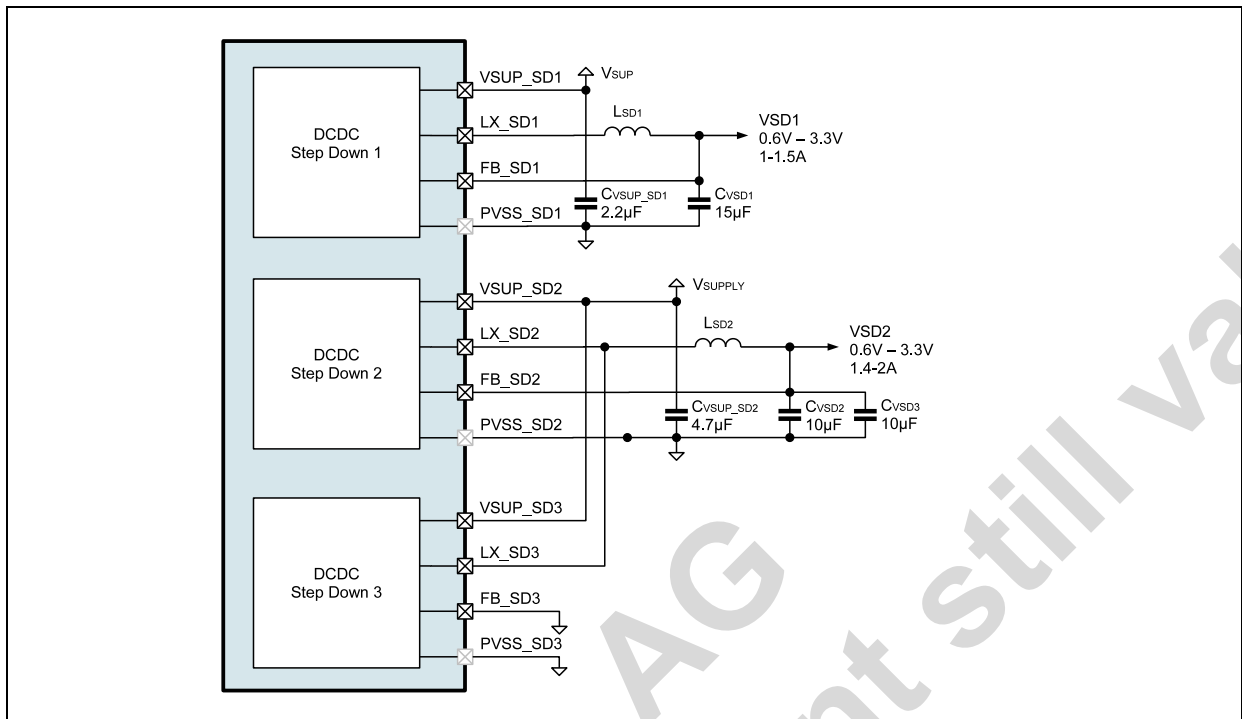

Figure 7. DC/DC step-down SD1, SD2, SD3 2A Operating Mode; *sd3\_slave* = 1

### 8.1.4 Parameter

Table 4. Step Down DC/DC Converter Parameters

Symbol	Parameter	Note	Min	Typ	Max	Unit
VIN	Input voltage	Pin VSUP_SDx	2.7		5.5	V
VOUT	Regulated output voltage		0.6125		3.35	V
VOUT_tol	Output voltage tolerance	min. 40mV	-3		+3	%
ILIMIT	Current limit	SD1		1.8		A
		SD2, SD3		1.2		A
RPSW	P-Switch ON resistance	SD1; VSUP_SDx=3.0V		0.17	0.4	Ω
		SD2, SD3; VSUP_SDx=3.0V		0.25	0.5	Ω
RNSW	N-Switch ON resistance	SD1; VSUP_SDx=3.0V		0.17	0.4	Ω
		SD2, SD3; VSUP_SDx=3.0V		0.25	0.5	Ω
Iload	Load current	SD1	0		1.5	A
		SD2, SD3	0		1	A
fsw	Switching frequency	sdX_frequ=1, sdX_fsel=1; fclk_int =4MHz		4		MHz
		sdX_frequ=1, sdX_fsel=0; fclk_int =4MHz		3		MHz
		sdX_frequ=0, sdX_fsel=0; fclk_int =4MHz		2		MHz
tmin_on	minimum on time			40		ns
ηeff	Efficiency	Iout=300mA, Vout=2V, VSUP=3.5V		92		%
IVDD	Current consumption	Operating current without load		60		µA
		Shutdown current		0.1		

Table 5. Step Down DC/DC External Components

Symbol	Parameter	Note	Min	Typ	Max	Unit
CFB_SD1	Output capacitor	Ceramic X5R or X7R	10.0	15		μF
		Ceramic X5R or X7R, fast mode=1	20.0	30		μF
CFB_SD2-3	Output capacitor	Ceramic X5R or X7R	8.0	10		μF
		Ceramic X5R or X7R, fast mode=1	16.0	20		μF
CVSUP_SD1-3	Input capacitor	Ceramic X5R or X7R		2.2		μF
LSD1-SD3	Inductor	4MHz operation		1		μH
		3MHz operation		1		
		2MHz operation		2.2		

All measurements were done with 55mΩ chip coils (Murata LQM2HPN1R0MG0). Using coils with lower on-resistance will increase the efficiency especially at higher output currents.

Figure 8. Step Down DC/DC SD1 Efficiency vs. Output Current;  $V_{SUP} = 3.0V$ , 3MHz operation,  $T_A = +25^\circ C$

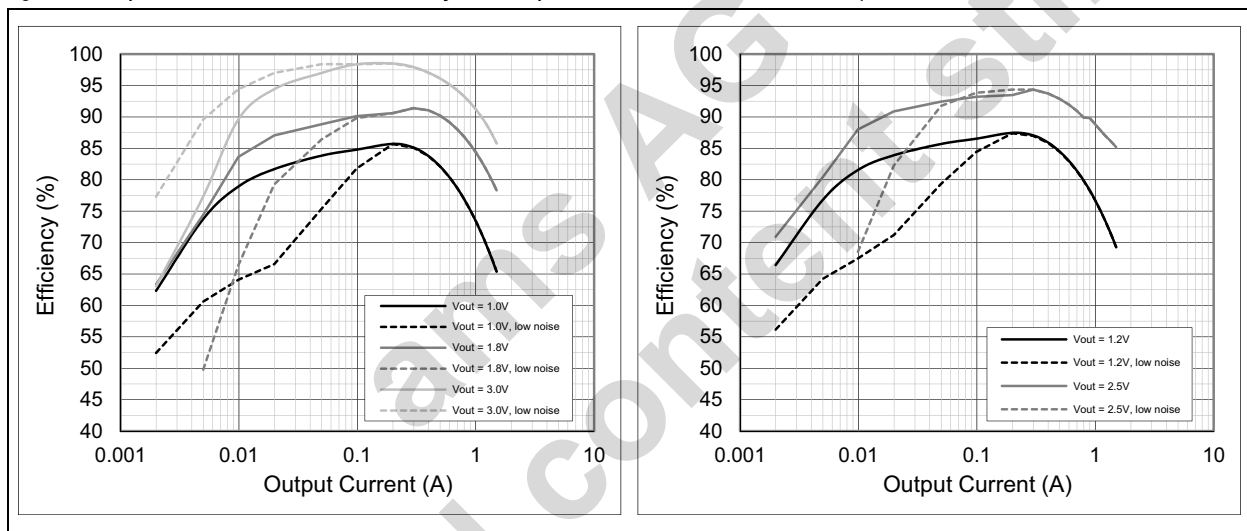

Figure 9. Step Down DC/DC SD1 Efficiency vs. Output Current;  $V_{SUP} = 3.8V$ , 3MHz operation,  $T_A = +25^\circ C$

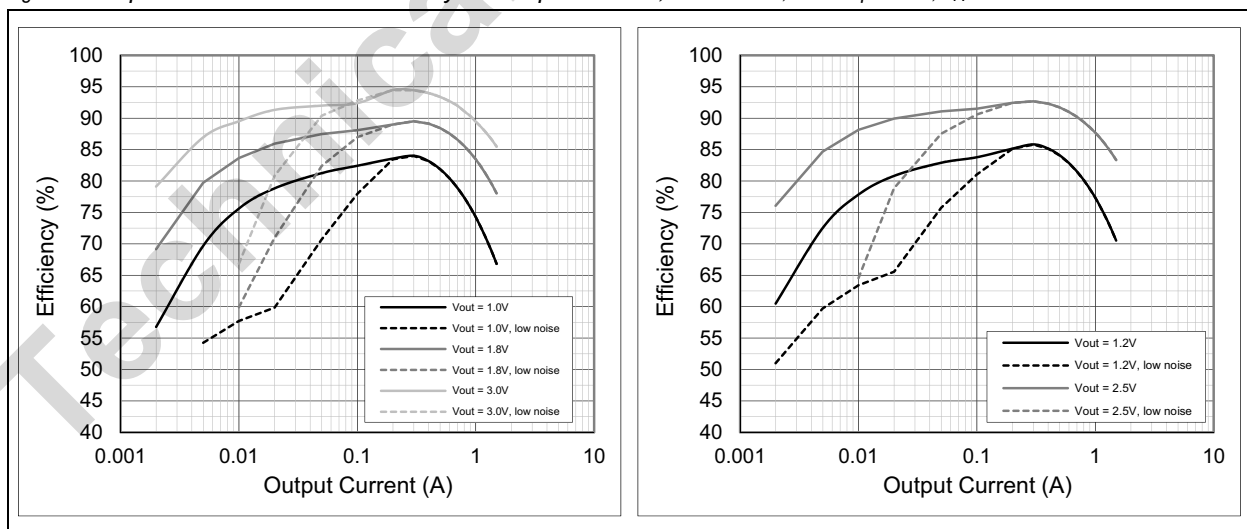

Figure 10. Step Down DC/DC SD2 & SD3 Efficiency vs. Output Current;  $V_{SUP} = 3.0V$ , 3MHz operation,  $T_A = +25^\circ C$

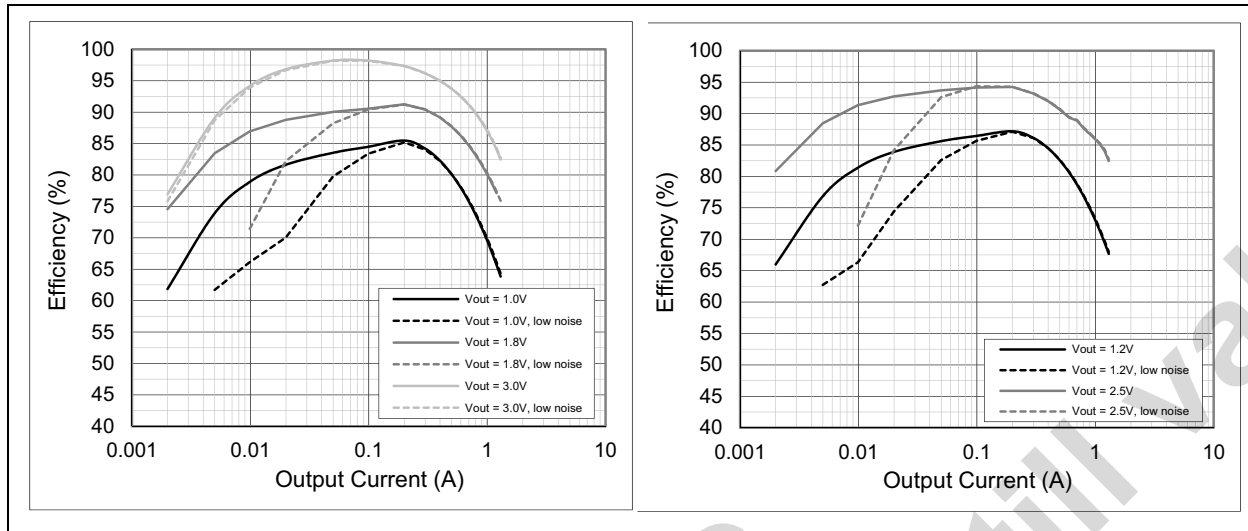
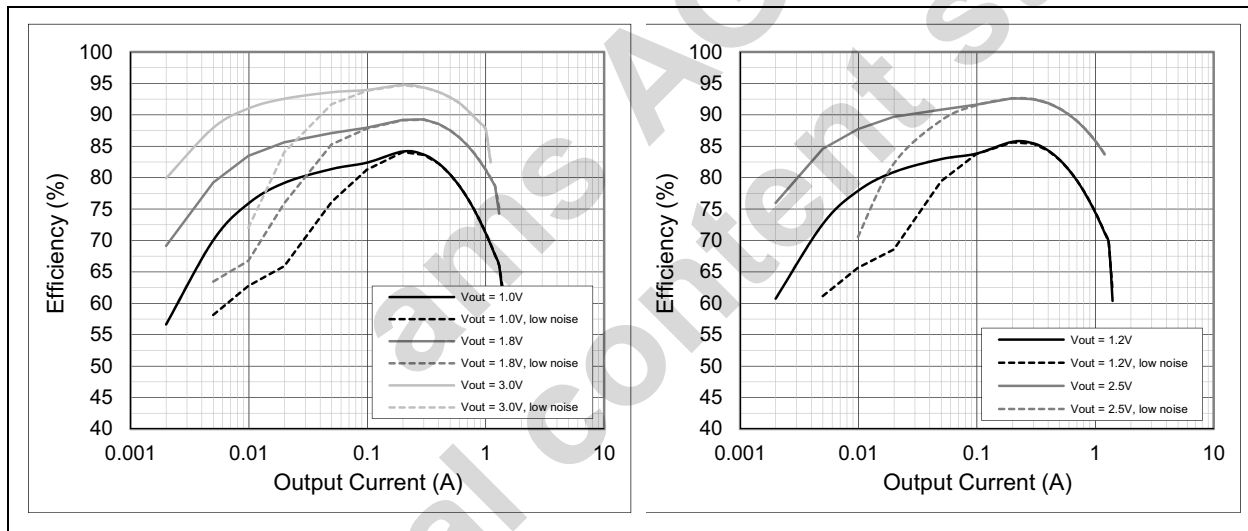

Figure 11. Step Down DC/DC SD2 & SD3 Efficiency vs. Output Current;  $V_{SUP} = 3.8V$ , 3MHz operation,  $T_A = +25^\circ C$





## 8.2 DCDC Step-Down Controller

### 8.2.1 General Description

The Step-Down controller SD4 uses a paired external NMOS, PMOS to achieve higher output currents. the maximum output current is determined by the external transistor and shunt used.

Figure 12. DC/DC step-down Controller

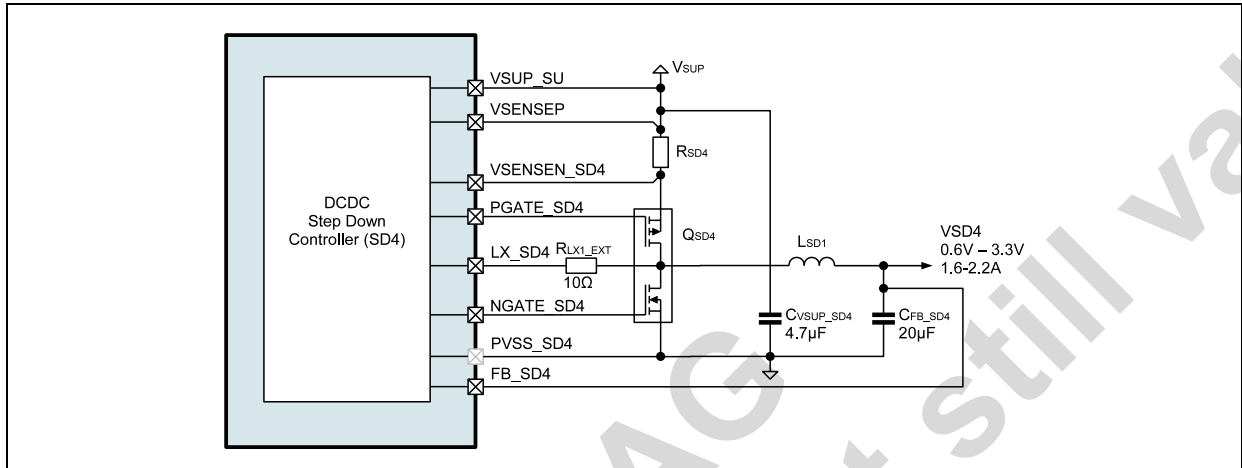

### 8.2.2 Parameter

Table 6. Step Down DC/DC Controller Parameters

Symbol	Parameter	Note	Min	Typ	Max	Unit
VIN	Input voltage	Pin VSUP_SDx	2.7		5.5	V
VOUT	Regulated output voltage		0.6125		3.3	V
VOUT_tol	Output voltage tolerance	min. 40mV	-3		+3	%
V <sub>rsense_max</sub>	Current limit voltage at R <sub>sense</sub>	E.g.: 2.6A for 0.033Ω sense resistor		100		mV
f <sub>sw</sub>	Switching frequency	fclk_int = 4MHz		1		MHz

Table 7. Step Down DC/DC Controller External Components

Symbol	Parameter	Note	Min	Typ	Max	Unit
<b>External Components 1.6A</b>						
QSD4	paired NMOS-PMOS	FDC6327C				PMOS: Ron=250mOhm, 1.6A NMOS: Ron=120mOhm, 2.7A
RSD4	shunt	0.15W; +/- 1%		50		mΩ
CFB_SD4	Output capacitor	Ceramic X5R or X7R	16.0	20		µF
		Ceramic X5R or X7R, fast mode=1	32.0	40		µF
CVSUP_SD4	Input capacitor	Ceramic X5R or X7R		10		µF
LSD4	Inductor	2A rated, 1MHz operation		2.2		µH
<b>External Components 2.2A</b>						
QSD4	paired NMOS-PMOS	FDC6420C				PMOS: Ron=190mOhm, 2.2A NMOS: Ron=95mOhm, 3A
RSD4	shunt	0.2W; +/- 1%		33		mΩ

Table 7. Step Down DC/DC Controller External Components

Symbol	Parameter	Note	Min	Typ	Max	Unit
CFB_SD4	Output capacitor	Ceramic X5R or X7R	24.0	30		$\mu\text{F}$
		Ceramic X5R or X7R, fast mode=1	48.0	60		$\mu\text{F}$
CVSUP_SU	Input capacitor	Ceramic X5R or X7R		10		$\mu\text{F}$
LSD4	Inductor	2.5A rated, 1MHz operation		1.5		$\mu\text{H}$
<b>External Components 3A</b>						
QSD4	paired NMOS-PMOS	NTHD3102C				PMOS: Ron=83mOhm, 4.2A NMOS: Ron=37mOhm, 5.5A
RSD4	shunt	0.3W; +/- 1%		25		m $\Omega$
CFB_SD4	Output capacitor	Ceramic X5R or X7R	32.0	40		$\mu\text{F}$
		Ceramic X5R or X7R, fast mode =1	64.0	80		$\mu\text{F}$
CVSUP_SU	Input capacitor	Ceramic X5R or X7R		10		$\mu\text{F}$
LSD4	Inductor	3A rated, 1MHz operation		1		$\mu\text{H}$

All measurements were done with the 2.2A transistors (Fairchild FDC6420C) and 70m $\Omega$  chip coils (Murata LQM2HPN1R0MG0). Using coils with lower on-resistance will increase the efficiency especially at higher output currents.

Figure 13. Step-Down DC/DC SD4 Controller Efficiency vs. Output Current;  $V_{SUP} = 3.0V$ ,  $T_A = +25^\circ\text{C}$ 

Figure 14. Step-Down DC/DC SD4 Controller Efficiency vs. Output Current;  $V_{SUP} = 3.8V$ ,  $T_A = +25^\circ C$



## 8.3 Analog LDO Regulators

### 8.3.1 General description

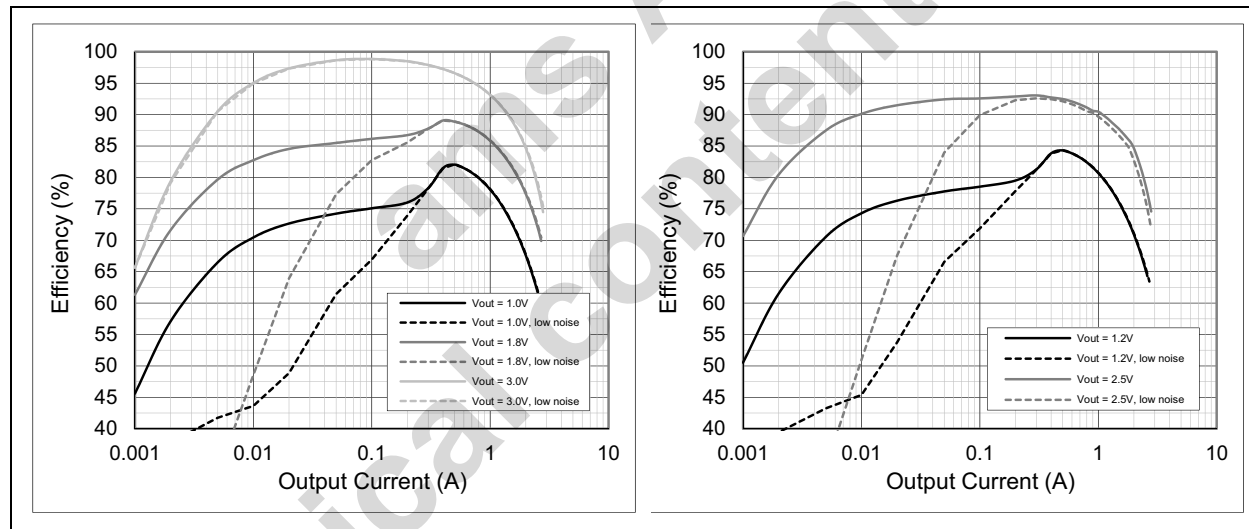
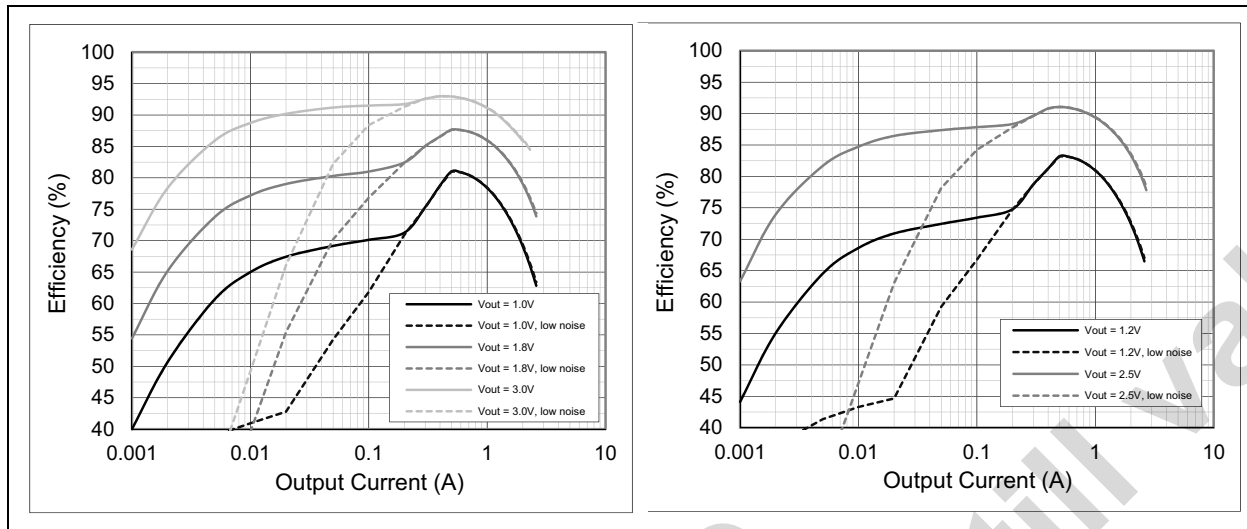
LDO1 and LDO2 are designed to supply sensitive analogue circuits like LNA's, Transceivers, VCO's and other critical RF components of cellular radios. Another application is the supply of audio devices or as a reference for AD and DA converters. The design is optimized to deliver the best compromise between quiescent current and regulator performance for battery powered devices.

Stability is guaranteed with ceramic output capacitors of  $1\mu\text{F} \pm 20\%$  (X5R) or  $2.2\mu\text{F} +100/-50\%$  (Z5U). The low ESR of these caps ensures low output impedance at high frequencies. Regulation performance is excellent even under low dropout conditions, when the power transistor has to operate in linear mode. Power supply rejection is high enough to suppress the PA-ripple on the battery in TDMA systems at the output. The low noise performance allows direct connection of noise sensitive circuits without additional filtering networks. The low impedance of the power device enables the device to deliver up to IOUT current even at nearly discharged batteries without any decrease of performance.

The default guaranteed operating current during start-up is 150mA, but can be set to 250mA with `IdoX_ilimit = 1`.

To save power in low-power states where the full performance is not needed the bias current can be reduce by setting `reg_low_bias_mode=1`.

Figure 15. Analog LDO Block diagram

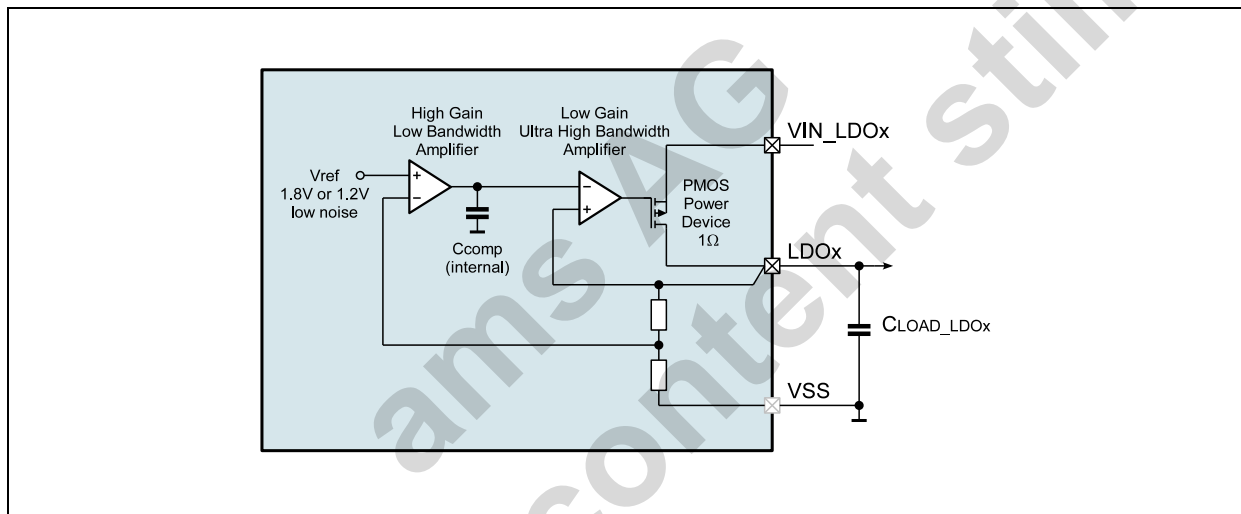

### 8.3.2 Parameter

Table 8. Analog LDO (LDO1, LDO2) Characteristics

$V_{LDO123\_IN}=3.7\text{V}$ ;  $I_{LOAD}=150\text{mA}$ ;  $T_{amb}=25^\circ\text{C}$ ;  $C_{LOAD}=2.2\mu\text{F}$  (Ceramic); unless otherwise specified

Symbol	Parameter	Note	Min	Typ	Max	Unit
VLDO123_IN	Supply voltage range		2.7		5.5	V
IOUT	Output current <sup>1</sup>	I <sub>doX</sub> _ilimit = 0	0		150	mA
		I <sub>doX</sub> _ilimit = 1	0		250	
R <sub>ON</sub>	On resistance	LDO1, LDO2			1	Ω
PSRR	Power supply rejection ratio	f=1kHz	70			dB
		f=100kHz	40			
I <sub>OFF</sub>	Shut down current				100	nA
I <sub>VDD</sub>	Supply current	without load		50		μA
		without load, <code>reg_low_bias_mode=1</code>		30		μA
Noise	Output noise	10Hz < f < 100kHz			50	μV <sub>rms</sub>
t <sub>start</sub>	Startup time	low current limit used during start-up			200	μs

Table 8. Analog LDO (LDO1, LDO2) Characteristics

$V_{LDO123\_IN}=3.7V$ ;  $I_{LOAD}=150mA$ ;  $T_{amb}=25^{\circ}C$ ;  $C_{LOAD}=2.2\mu F$  (Ceramic); unless otherwise specified

Symbol	Parameter	Note	Min	Typ	Max	Unit
$V_{out}$	Output voltage		1.2		3.3	V
$V_{out\_tol}$	Output voltage tolerance	min. 40mV	-3		3	%
$V_{LineReg}$	Line regulation	Static	-1		1	mV
		Transient; Slope: $t_r=10\mu s$	-10		10	
$V_{LoadReg}$	Load regulation	Static	-1		1	mV
		Transient; Slope: $t_r=10\mu s$	-10		10	
$I_{LIMIT\_LDO1,2\_L}$	low current limit	$I_{doX\_ilimit} = 0$		300		mA
$I_{LIMIT\_LDO1,2\_H}$	high current limit	$I_{doX\_ilimit} = 1$		500		mA
$C_{LOAD\_LDO1,2\_L}$	Ceramic load capacitor	LDO1 / LDO2; $I_{doX\_ilimit} = 0$	1		5	$\mu F$
$C_{LOAD\_LDO1,2\_H}$	Ceramic load capacitor	LDO1 / LDO2; $I_{doX\_ilimit} = 1$	2		5	$\mu F$

1. Guaranteed by design and verified by laboratory evaluation and characterization; not production tested.

## 8.4 Digital LDO Regulators

### 8.4.1 General Description

Digital LDOs offer a wide input (1.8V to 5.5V) as well as a wide output (0.9 to 3.3V) voltage range to be used for general purpose peripheral supply. Up to 300mA possible output currents are offered with good noise and regulation performance and very low quiescent current even suitable for stand-by power supply.

Figure 16. Digital LDO Block diagram

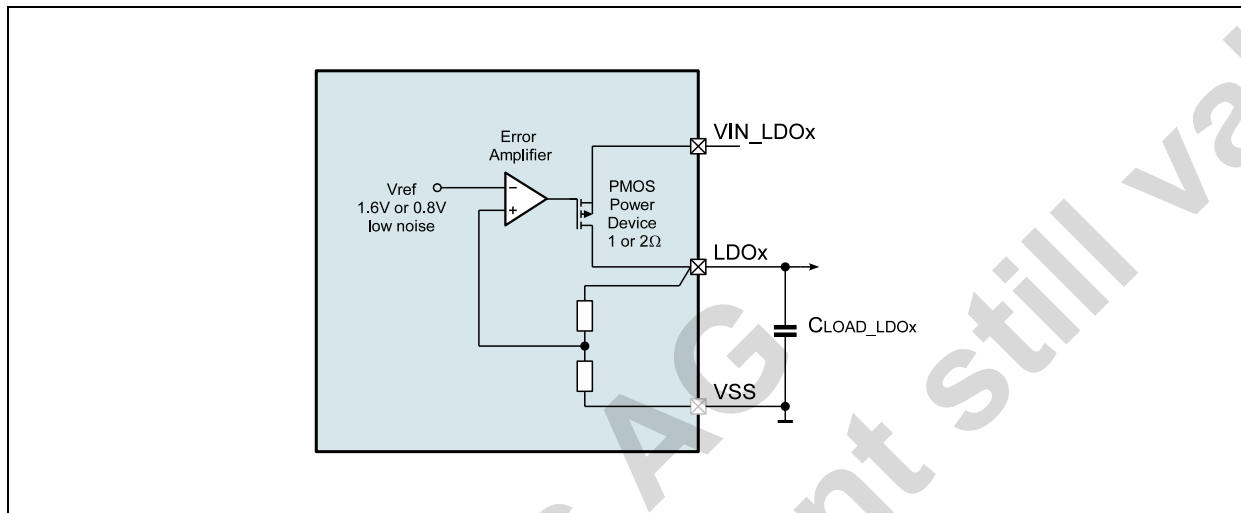

### 8.4.2 Parameter

Table 9. Digital LDO (LDO3, LDO4, LDO5, LDO6, LDO7, LDO8) Characteristics  
 VLDOx\_IN=3.7V; ILOAD=150mA; Tamb=25°C; CLOAD =1μF (Ceramic); unless otherwise specified

Symbol	Parameter	Note	Min	Typ	Max	Unit
VLDO123_IN	Supply voltage range		2.7		5.5	V
VLDO456_IN	Supply voltage range		1.75		5.5	V
VLDO78_IN	Supply voltage range		1.75		5.5	V
IOUT	Output current <sup>1</sup>	I <sub>doX</sub> _ilimit = 0	0		150	mA
		I <sub>doX</sub> _ilimit = 1	0		300	mA
RON	On resistance	LDO4, LDO5, LDO6			1	Ω
		LDO3, LDO7, LDO8			2	Ω
PSRR	Power supply rejection ratio	f=1kHz	60			dB
		f=100kHz	30			
IOFF	Shut down current			100		nA
IVDD	Supply current	without load		30	43	μA
tstart	Startup time	low current used during start-up			200	μs
Vout	Output voltage	V <sub>supply</sub> >3.0V, V <sub>CP</sub> =5.2V, I <sub>out</sub> <200mA	0.9		3.3	V
Vout_tol	Output voltage tolerance	min. 40mV	-3		3	%
VLineReg	Line regulation	Static		0.07		%/V
		Transient; Slope: tr=15μs; delta 1V		20		mV
VLoadReg	Load regulation	Static		0.014		%/mA
		Transient; Slope: tr=15μs; 1mA->300mA		30		mV

Table 9. Digital LDO (LDO3, LDO4, LDO5, LDO6, LDO7, LDO8) Characteristics  
 VLDO<sub>x</sub>\_IN=3.7V; ILOAD=150mA; Tamb=25°C; CLOAD =1μF (Ceramic); unless otherwise specified

Symbol	Parameter	Note	Min	Typ	Max	Unit
ILIMIT_LDO3-8_L	low current limit	I <sub>doX</sub> _ilimit = 0		300		mA
ILIMIT_LDO3-8_H	high current limit	I <sub>doX</sub> _ilimit = 1		500		mA

1. Guaranteed by design and verified by laboratory evaluation and characterization; not production tested

ams AG  
 Technical content still valid

## 8.5 Low power LDO V2\_5 Regulators

### 8.5.1 General Description

The low power LDO V2\_5 is needed to supply the chip core (analog and digital) of the device. It is designed to get the lowest possible power consumption, and still offering reasonable regulation characteristics. The regulator has two supply inputs selecting automatically the higher one. This gives the possibility to supply the chip core either with the battery or with the charger depending on the conditions. Bulk switch comparators are used to avoid any parasitic current flow. To ensure high PSRR and stability, a low-ESR ceramic capacitor of min. 1  $\mu$ F must be connected to the output.

### 8.5.2 Parameter

Table 10. Low power LDO (V2\_5) Characteristics,  $V_{BAT}=3.7V$ ;  $I_{LOAD\_ext}=0$ ;  $T_{amb}=25^{\circ}C$ ;  $C_{LOAD}=1 \mu F$  (Ceramic); unless otherwise specified

Symbol	Parameter	Note	Min	Typ	Max	Unit
$V_{BAT}$	Supply voltage range		2.7		5.5	V
$V_{USB}$			4.2		5.5	
$R_{ON}$	On resistance	Guaranteed per design		50		$\Omega$
$I_{OFF}$	Shut down current			100		nA
$I_{VDD}$	Supply current	Guaranteed per design, consider chip internal load for measurements.		3		$\mu A$
$t_{start}$	Startup time			200		$\mu s$
$V_{out}$	Output voltage		2.4	2.5	2.6	V



## 8.6 DCDC Step-Up Converter

### 8.6.1 General Description

The DC/DC Step Up converter is a high efficiency current mode PWM regulator, which provides an output voltage dependent on the maximum VDS voltage of the external transistor, and maximum load current selectable by the external shunt resistor.

For Example:

- 5V, 0.5-1A @ 1Mhz
- 25V, 50mA @ 1MHz
- 40V, 20mA @ 500kHz

A constant switching frequency results in a low noise on supply and output voltage.

Figure 17. DC/DC step-up Converter 1

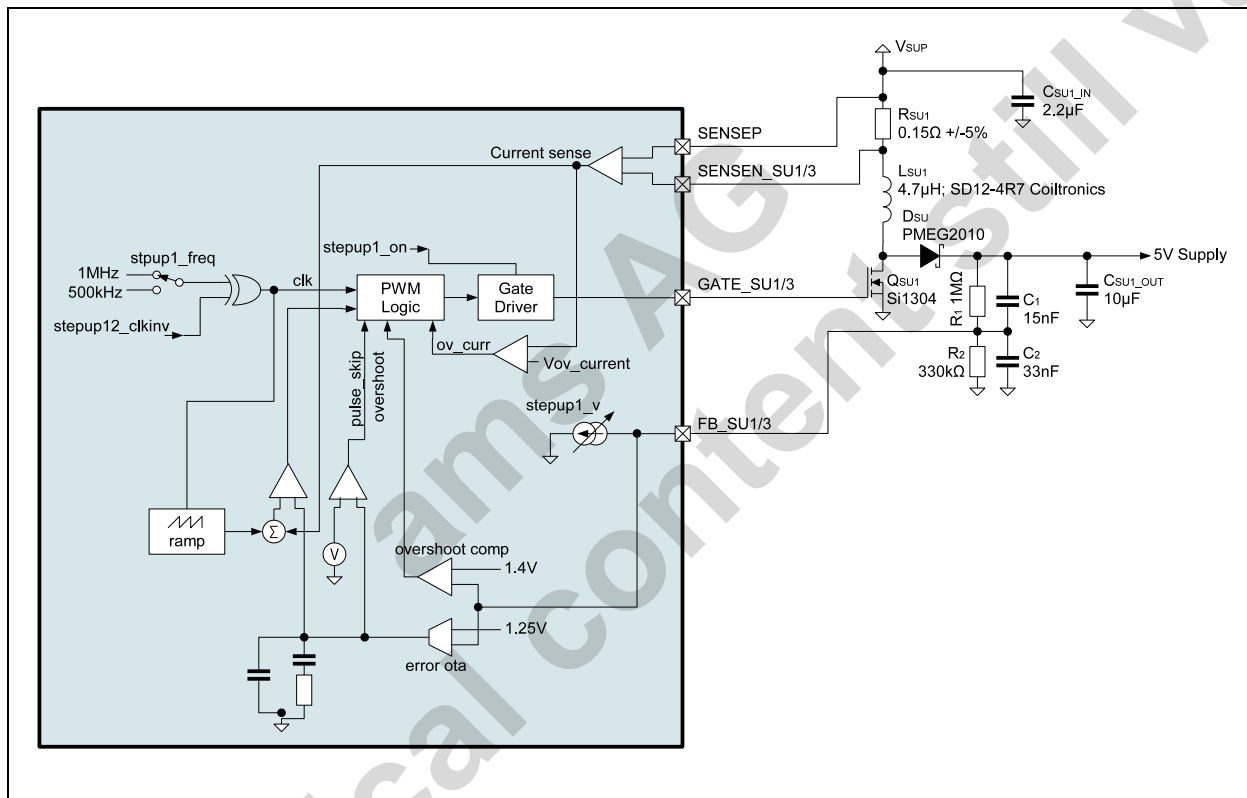
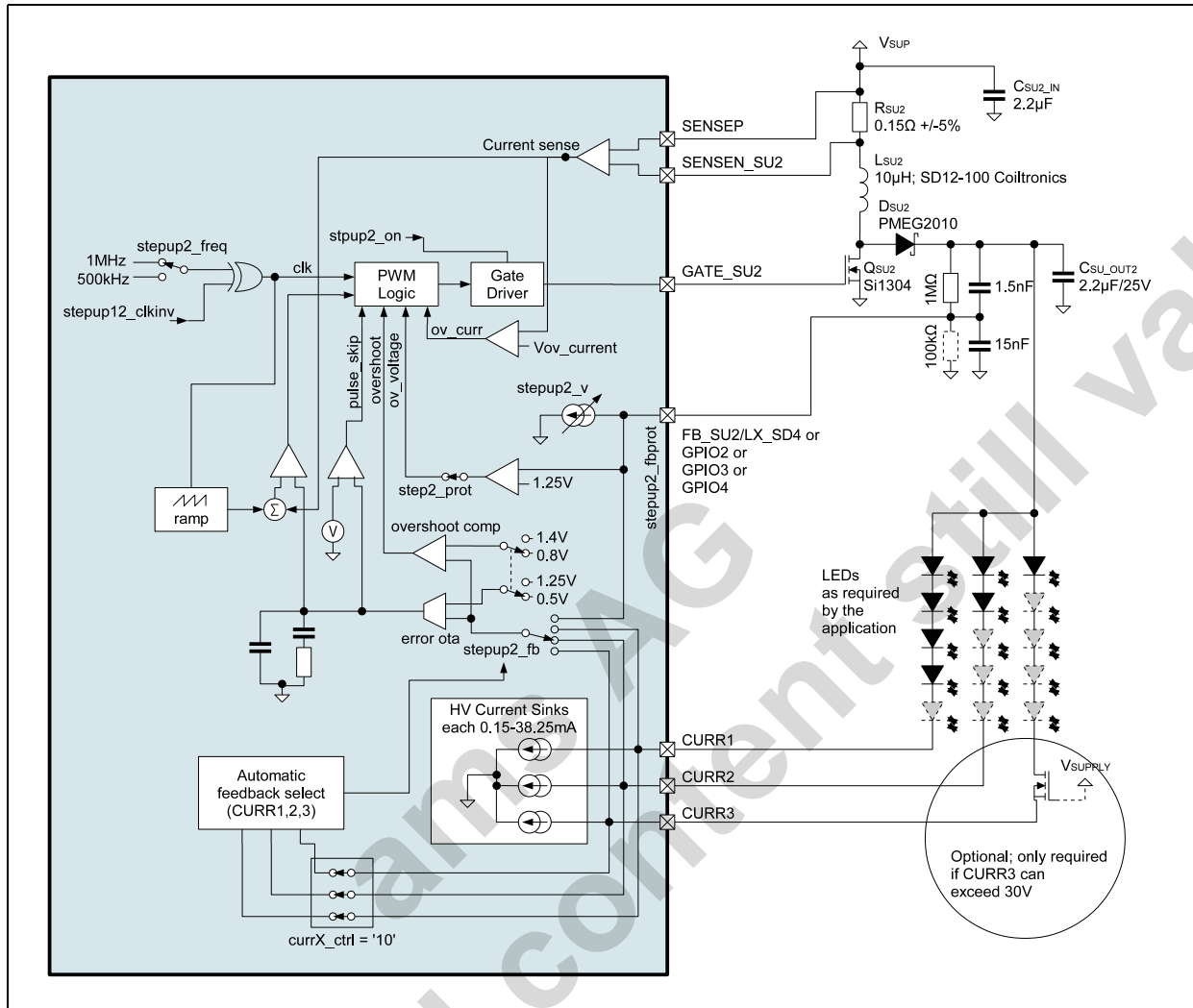

Figure 18. DC/DC step-up Converter 2



### 8.6.2 Feedback selection SU1

For step up SU1, the feedback is always FB\_SU1.

### 8.6.3 Feedback Selection SU2

For step up SU2 following feedback selections are possible (selected by setup2\_fb): (see Figure 18)

#### Current Feedback

CURR1, CURR2 or CURR3 can be selected by **stepup2\_fb** as a current feedback pin.

The step-up converter is regulated such that the required current at the feedback path can be supported. **stepup2\_fbprot** selects the over-voltage protection feedback pin (LX\_SD4, GPIO2, GPIO3 or GPIO4). In this mode the output voltage will be limited by limiting the voltage on the selected feedback pin to 1.25V (select the external resistor network and **stepup2\_v** to adjust this limitation voltage).

**stepup2\_prot\_dis** has to be set to 0, otherwise the protection is disabled.

Always choose the path with the higher voltage drop as feedback to guarantee adequate supply for the other, unregulated path.

#### Current Feedback with Automatic Feedback Selection

Same as above, but when currX\_ctrl = 10b for the used current sinks, the chip automatically selects the highest string (CURR1, CURR2 or CURR3) as feedback input.

### Voltage Feedback

**stepup2\_fb** = 00b. LX\_SD4, GPIO2, GPIO3 or GPIO4 can be selected by **stepup2\_fbprot** as a voltage feedback input.

The step-up converter output voltage is regulated by regulating the selected feedback pin voltage to 1.25V.

### Calculating Resistors for Voltage Feedback or Over-Voltage Protection

Bit **stepupX\_res** should be set to 1 in voltage feedback mode using two resistors.

The output voltage is regulated to a constant value, given by:

$$V_{SU} = \frac{R_1 + R_2}{R_2} \times 1,25 + I_{FB} \times R_1$$

If R2 is not used, the output voltage is:

$$V_{SU} = 1,25 + I_{FB} \times R_1$$

V<sub>SU</sub>: Step up regulator output voltage

R<sub>1</sub> Feedback resistor R1

R<sub>2</sub> Feedback resistor R2

I<sub>FB</sub>: Tuning current on DCDC\_FB pin: stepupX\_v (0..31µA (1µA steps))

Example:

Table 11. Step Up Output Voltage (Voltage mode or protection voltage)

IFB (stepupX_v)	Vsu	Vsu
µA	R1=1M Ω,R2 not used	R1=500k Ω,R2=64k Ω
0	-	11
1	-	11.5
2	-	12
3	-	12.5
4	-	13
5	6.25	13.5
6	7.25	14
7	8.25	14.5
8	9.25	15
9	10.25	15.5
10	11.25	16
11	12.25	16.5
12	13.25	17
13	14.25	17.5
14	15.25	18
15	16.25	18.5

**Note:** The voltage on pin CURR1, CURR2 and CURR3 must never exceed 30V.

### 8.6.4 Output disconnect

As the output voltage is always on, an additional output transistor can be added to reduce shutdown current through R1, R2 and the connected output circuit.

**Note:** A similar circuit can be used for step up converter 2.

Figure 19. StepUp 1 with regulated output voltage (15V), and switch off function of output voltage, to reduce shutdown current

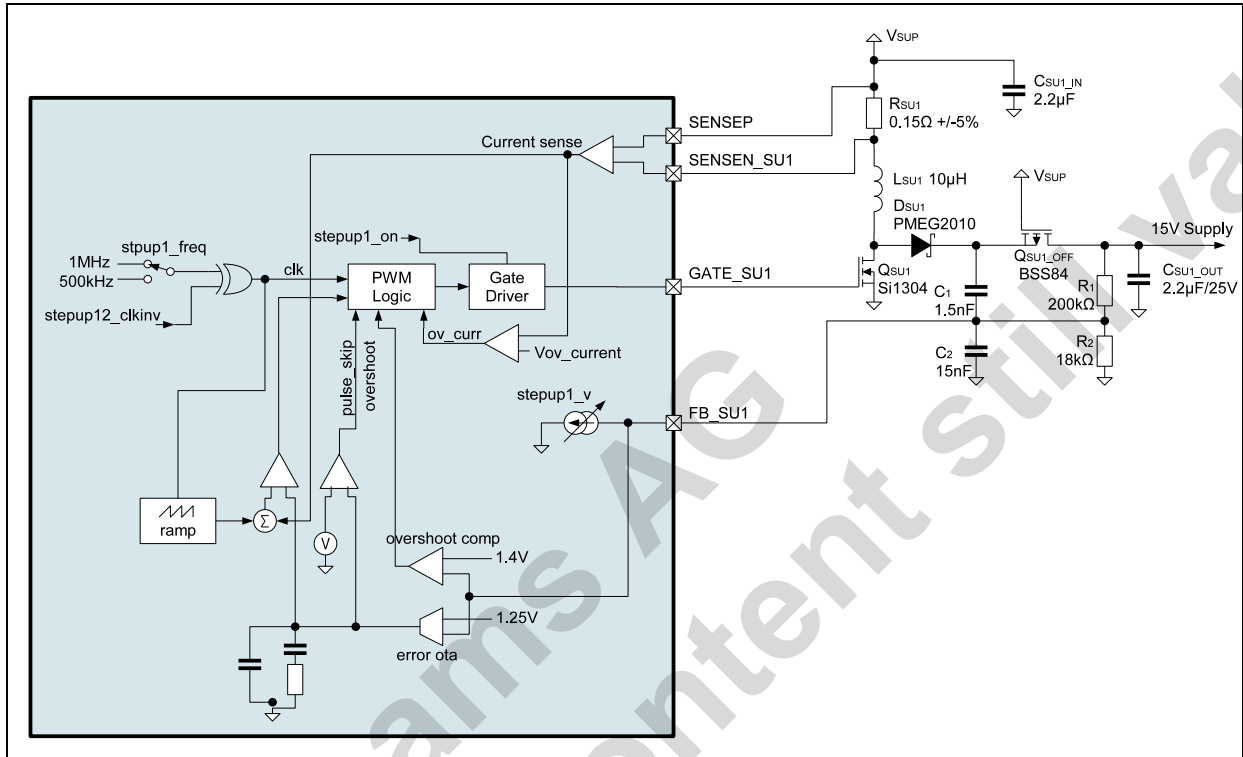

### 8.6.5 StepUp1 Load Detection and Over-current Protection Circuit

This circuit protects the DCDC step up1 converter during short circuit and startup, by regulation of the output current.

An additional feature is the detection of a minimum output load of the Step-up converter. It is also possible to use this circuit without the DCDC step up converter, by using the sense resistor only:

- Detection circuit: If the voltage on  $R_{sense}$  exceeds  $V_{DETECT}$  for more than 1ms, or the DCDC Step up converter is not in pulse-skip for more than 1ms, the `stepup1_det` bit will be set.
- Over-current protection: If the Over-current voltage  $V_{OVCURRENT}$  has been exceeded by more than 5ms the bit `stpup1_oc` will be set and can only reset, by switching off and on the Protection circuit by writing `stpup1_shortprot 0 - 1`. If `stpup1_oc` is set the load will be disconnected, if `stpup1_oc_timeout=1`

Figure 20. StepUp 1 Load Detection and Over-current Protection Application Circuit

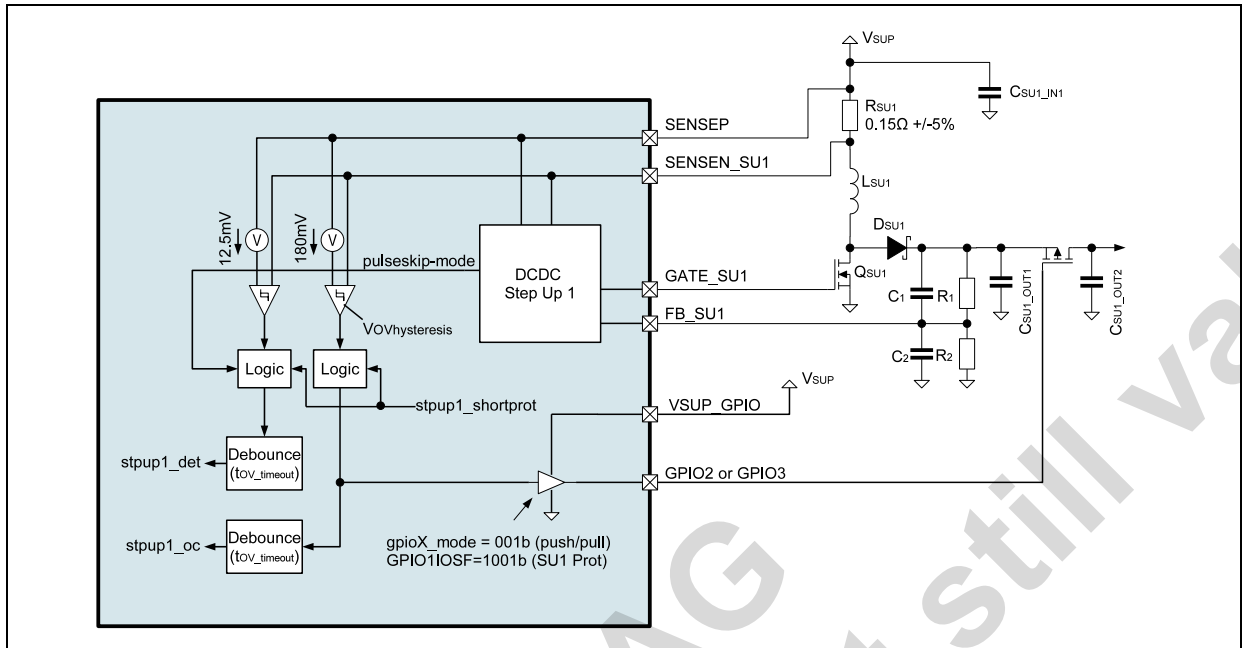

### 8.6.6 Parameter

Table 12. DC/DC Step-up Controller Parameters

Symbol	Parameter	Note	Min	Typ	Max	Unit
I <sub>VDD</sub>	Quiescent Current	Pulse skipping mode		140		μA
V <sub>FB1</sub>	Feedback voltage for external resistor divider:	for constant voltage control	1.20	1.25	1.30	V
V <sub>FB2</sub>	Feedback voltage for current sink regulation	CURR1, CURR2 or CURR3		0.6		V
I <sub>DCDC_FB</sub>	Additional tuning current at FB_SUX	adjustable by software in 1 μA steps	0		31	μA
	Accuracy of feedback current	@ full scale	-7		7	%
V <sub>rsense_max</sub>	Current limit voltage at Rsense	E.g.: 0.65A for 0.15Ω sense resistor		100		mV
R <sub>SW</sub>	switch resistance	ON-resistance of external switching transistor			1	Ω
I <sub>load</sub>	Load current	at 25V output voltage	0		50	mA
f <sub>IN</sub>	Switching frequency	internal CLK frequency/4, default 1MHz		f <sub>clk_int</sub> /4		MHz
t <sub>MIN_ON</sub>	Minimum on time			130		ns
MDC	Maximum duty cycle	@ 1MHz		91		%

Table 13. StepUp1 protection/detection circuit parameters

Symbol	Parameter	Note	Min	Typ	Max	Unit
VDETECT	Detection Threshold	For Rsense=0.150Ω => 83mA typ.	2	12.5	25	mV
VOVCURRENT	Over-current Threshold rising	For Rsense=0.150Ω => 1.2A typ.	150	180	215	mV

Table 13. StepUp1 protection/detection circuit parameters

Symbol	Parameter	Note	Min	Typ	Max	Unit
VOVhysteresis	Over-current Hysteresis			50		mV
tOV_timeout	Over-current timeout	Interrupt and/or external PMOS switching off after timeout $f_{clk\_int} = 2.2\text{MHz}$		5		ms
tdetect	Detection de-bounce time	$f_{clk\_int} = 2.2\text{MHz}$		1		ms

Table 14. DC/DC Step-up Controller External Components

Symbol	Parameter	Note	Min	Typ	Max	Unit
C <sub>out</sub>	Output capacitor	ceramic, $\pm 20\%$		2.2		$\mu\text{F}$
L <sub>SU</sub>	Inductor	Use inductors with small C <sub>parasitic</sub> (<100pF) to get high efficiency; V <sub>out</sub> >8V		10		$\mu\text{H}$
		Use inductors with small C <sub>parasitic</sub> (<100pF) to get high efficiency; V <sub>out</sub> <8V		4.7		$\mu\text{H}$
Q <sub>SU</sub>	Transistor	V <sub>GS(TH)</sub> threshold voltage		1.3	1.5	V
		V <sub>DS</sub> max drain to source voltage	V <sub>out_max</sub> +20%			V
		R <sub>DS(ON)</sub> drain - source on resistance		0.35		$\Omega$
		Q <sub>GS</sub> total gate charge @ V <sub>GS</sub> =4.5V		3	5	nC
C <sub>1</sub> / C <sub>2</sub>	Feedback capacitor ratio	ratio should be smaller than the feedback resistor ratio (inverted) to avoid overshoots during start-up			R <sub>2</sub> / R <sub>1</sub>	$\mu\text{F}$

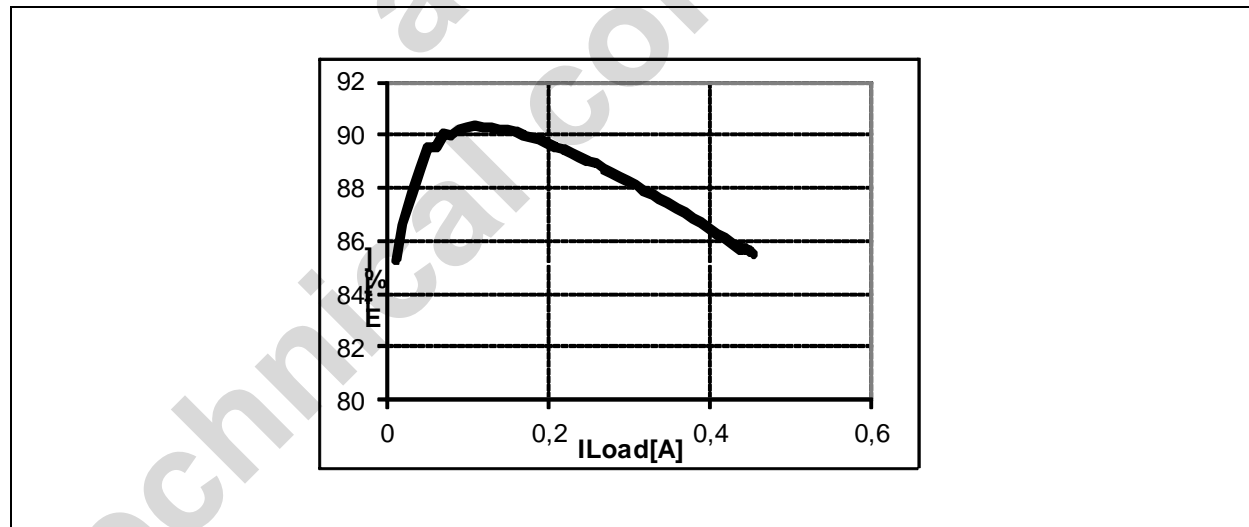
8.6.7 Step-Up DC/DC Controller Efficiency vs. Output Current; V<sub>SUP</sub> = 3.8V, T<sub>A</sub> = +25°C

## 8.7 Current Sinks

### 8.7.1 General Description

These are general-purpose current sinks intended to control the backlight(s), buzzer and vibrator. CURR1 and CURR2, CURR3 are high voltage (30V) current sinks, e.g. for series of white LEDs.

Current sinks CURR1, CURR2 and CURR3 can be controlled individually. The step-up DCDC converter (SU2) may supply them with voltages up to 30V. For an automatic feedback selection the used current sinks can be assigned to the SU2 booster.

If not used as a current sink, CURR3 can be used to output several status signals. In this mode the CURR3 output acts like an open-drain output and needs an external pull-up resistor for generating logic high levels.

### 8.7.2 Parameter

Table 15. Current Sinks Characteristics

Symbol	Parameter	Note	Min	Typ	Max	Unit
I <sub>CURR1,2,3</sub>	CURR1,2 & 3 current, 00h-3Fh	For V(DCDC_CURRx) > 0.5V resolution = 0.157mA	0		40	mA
I <sub>DCDC_protect</sub>	Current sink protection Current	Protection Current if stpup2_on=1 and currx_current=00h		2		μA
Δ	absolute Accuracy	All Current sinks	-8		+8	%
V <sub>CURR1,2,3</sub>	Voltage compliance	during normal operation	0.5		30	V

## 9 Detailed Description - System Functions

### 9.1 Start-up

Figure 21. Startup flow chart

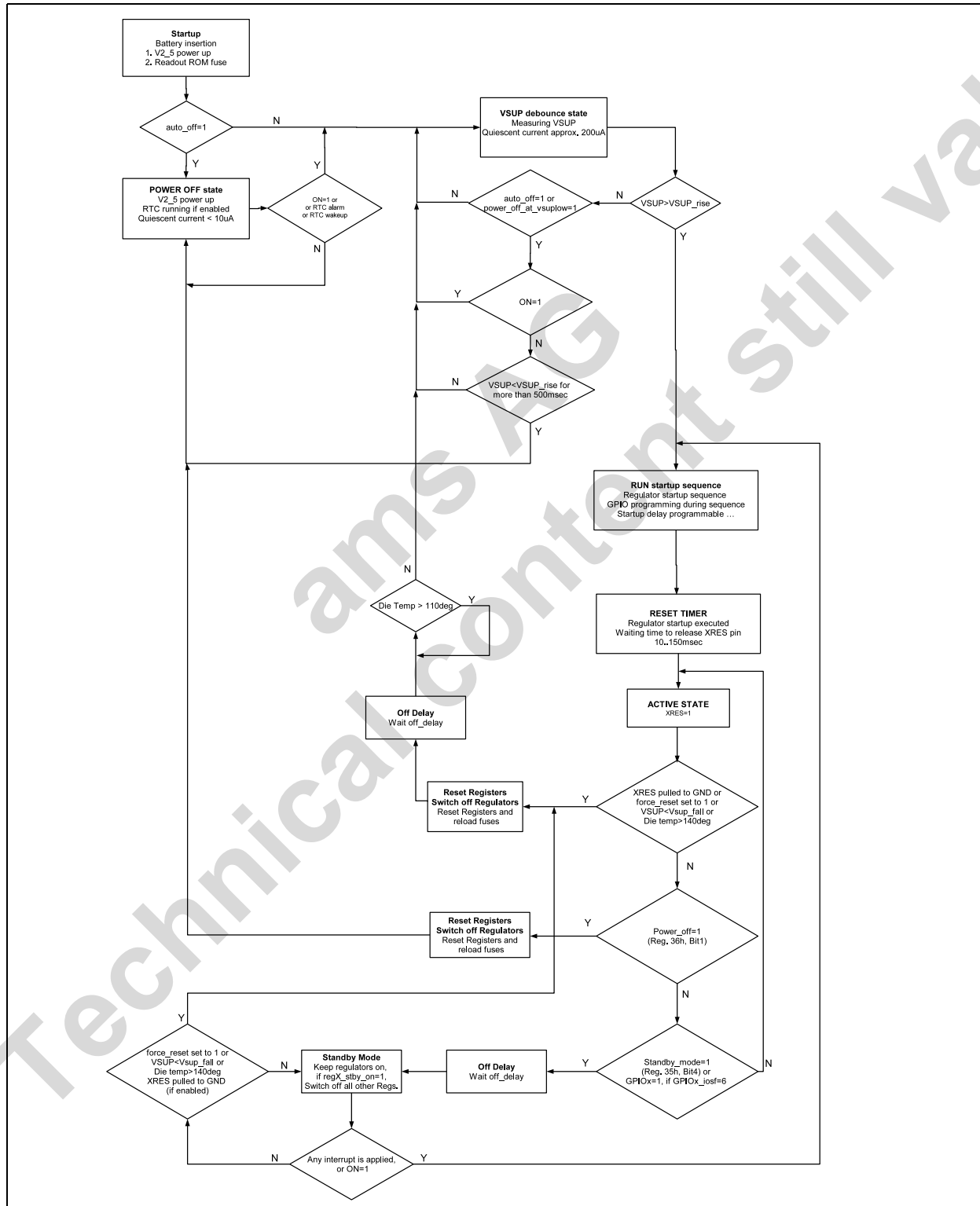



### 9.1.1 Normal Startup

During a normal reset cycle (e.g. after the battery is inserted), after V2\_5 is above  $V_{POR}$  and VSUP is above ResVoltRise a normal startup happens:

- The external capacitor on CREF is charged to 1.8V.
- Configuration of SD2/SD3 (combined mode or separated) is read from the Boot-OTP.
- Startup State machine reads out the internal Boot-OTP. The start-up sequence of Step-Down Converter, LDO's and GPIOs are controlled by the Boot-OTP.
- Reset-Timer is set by the Boot-OTP
- The reset is released when the Reset Timer expires (external pin XRES)

### 9.1.2 Parameter

Table 16. Charger and ON-input Startup Conditions

Symbol	Parameter	Note	Min	Typ	Max	unit
VSTARTCHARGER	Voltage on VUSB for system to start	on Pin VUSB	4.2	5.0	30	V
V <sub>ON_IL</sub>	ON Low Level input voltage		-0.3		0.4	
V <sub>ON_IH</sub>	ON High Level input		1.4		V <sub>VSUP_GPIO</sub>	
I <sub>ON_PD</sub>	ON Pull down current		4	12		μA

## 9.2 Reset

### 9.2.1 General Description

XRES is a low active bi-directional pin. An external pull-up to the periphery supply has to be added.

During each reset cycle the following states are controlled by the AS3713:

- pin XRES is forced to GND
- normal startup with programmable power-on sequence and regulator voltages (see Start-up on page 31)
- reset is active until the programmable reset timer (set by register bits *res\_timer<2:0>*) expires
- all registers are set to their default values after power-on, except the reset control- and status-registers.
- XRES is pulled high by the external resistor and the whole system is leaving the reset state

**Note:** Programming is controlled by the internal Boot-OTP

### 9.2.2 Parameter

Table 17. XRES-input Characteristics

Symbol	Parameter	Note	Min	Typ	Max	Unit
V <sub>XRES_IL</sub>	XRES Low Level input voltage		-0.3		0.4	V
V <sub>XRES_IH</sub>	XRES High Level input voltage		1.4		VSUP_G PIO	V

### 9.2.3 Reset Conditions

Reset can be activated from 7 different sources:

- Power on (battery insertion)
- Low Battery
- Software forced reset
- Power off mode
- External triggered through the pin XRES
- Over-temperature
- Watchdog
- On-key long press

*Voltage detection:*

There are two types of voltage dependent resets: V<sub>POR</sub> and V<sub>XRES</sub>. V<sub>POR</sub> monitors the voltage on V2\_5 and V<sub>XRES</sub> monitors the voltage on VSUP. The linear regulator for V2\_5 is always on and uses the voltage VSUP as its source.

The pin XRES is only released if V2\_5 is above V<sub>POR</sub> and VSUP is above ResVotIRise.

Table 18. Reset Levels

Symbol	Parameter	Note	Min	Typ	Max	Unit
V <sub>POR</sub>	Overall power on reset	Monitor voltage on V2_5; power on reset for all internal functions	1.5	2.0	2.3	V
VXRES <sub>RISE</sub>	Reset level for V <sub>supply</sub> rising	Monitor voltage on VSUP; rising level		ResVolt Rise <sup>1</sup>		V
VXRES <sub>FALLING</sub>	Reset level for V <sub>supply</sub> falling	Monitor voltage on VSUP; falling level		2.7		V
		if <b>SupResEn</b> =1 only		ResVoltFall		V
VXRES <sub>MASK</sub>	Mask time for VXRES <sub>FALLING</sub> . Duration for VBAT<ResVoltFall until a reset cycle is started <sup>2</sup>	<b>FastResEn</b> = 0		3		ms
		<b>FastResEn</b> = 1		4		us

1. It's recommended to set the ResVoltRise level 200mV above the ResVolt Fall level to have a hysteresis.
2. XRES signal is de-bounced with the specified mask time for rising- and falling slope of VBAT.

**Note:** VXRES<sub>FALLING</sub> is only accepted if the reset condition is longer than VXRES<sub>MASK</sub>. This guard time is used to avoid a complete reset of the system in case of short drops of VBAT.

#### Power off:

To put the chip into ultra low power mode, write '1' into *power\_off*. The chip stays in power off mode until the external pin ON is pulled high, the charger is inserted or the level V<sub>POR</sub> is touched to start a complete reset cycle. The bit *power\_off* is automatically cleared by this reset cycle. During *power\_off* state all circuits are shut-off except the Low Power LDO (V2\_5). Thus the current consumption of AS3713 is reduced to less than 15 µA. The digital part is supplied by V2\_5, all other circuits are turned off in this mode, including references and oscillator. Except the reset control registers all other registers are set to their default value after power-on.

#### Software forced reset

Writing '1' into the register bit *force\_reset* immediately starts a reset cycle. The bit *force\_reset* is automatically cleared by this reset.

#### External triggered reset:

If the pin XRES is pulled from high to low by an external source (e.g. microprocessor or button) a reset cycle is started as well.

#### Over-temperature reset:

The reset cycle can be started by over-temperature conditions. (see Supervisor on page 40)

#### Watchdog reset:

If the watchdog is armed (register bit *wtdg\_on* = 1 and *wtdg\_res\_on* = 1) and the timer expires it causes a reset. (see Watchdog on page 41).

#### Long ON-key press:

When applying a high level on the ON input pin for 4s/8s (depending on *on\_reset\_delay*) a reset is initiated. This is thought as a safety feature when the SW hangs up and no watchdog is used.

## 9.3 Stand-by

### 9.3.1 General Description

Stand-by allows shutting down a part or the complete system. Stand-by can be terminated by every possible interrupt or GPIO of the PMU. The interrupt has to be enabled and GPIO has to be configured before going to hibernation.

Table 19. Hibernation

State	Description
Enter via GPIO	To enter stand-by mode the following settings have to be done: <ul style="list-style-type: none"> <li>- Enable just these IRQ sources which should lead to leave hibernation mode.</li> <li>- Make sure that IRQ is inactive (IRQ flags get cleared by register reading)</li> <li>- Set the GPIO to input (gpioX_mode = 0)</li> <li>- Set the GPIO for stand-by control (gpioX_iosf = 6)</li> <li>- Set regX_select and regX_voltage if an other voltage is needing during stand-by for up to 3 regulators</li> <li>- Define which regulators should be kept powered during stand-by (sdX_stby_on, ldoX_stby_on)</li> <li>- set <b>chg_pwr_off_en</b> to 1</li> <li>- Activate the selected GPIO</li> </ul>
Enter via SW	To enter stand-by mode the following settings have to be done: <ul style="list-style-type: none"> <li>- Enable just these IRQ sources which should lead to leave hibernation mode.</li> <li>- Make sure that IRQ is inactive (IRQ flags get cleared by register reading)</li> <li>- Set the delay for going into stand-by after the SW command (<b>off_delay</b>)</li> <li>- Define which regulators should be kept powered during stand-by (sdX_stby_on, ldoX_stby_on)</li> <li>- set <b>chg_pwr_off_en</b> to 1</li> <li>- set <b>standby_mode_on</b> to 1</li> </ul>
Hibernation	V2_5 chip supply is kept ON All other regulators are switched OFF dependent on the stby_on bits XRES goes active (can be disabled in the boot ROM) and pwr_good goes inactive
Leave	The chip will come out of stand-by with <ul style="list-style-type: none"> <li>- IRQ activation or</li> <li>- GPIO control (if entered via GPIO or interrupt)</li> </ul> Start-Up sequence is provided defined by the boot ROM.

## 9.4 Internal References

The internal reference circuits needs the following external components:

Table 20. Reference External Components

Symbol	Parameter	Note	Min	Typ	Max	Unit
CEXT	External filter capacitor	Ceramic low-ESR capacitor between CREF and VSS	-10%	100	+10%	nF

### 9.4.1 Low Power Mode

Use bit *low\_power\_on* to activate the Low Power Mode. In this mode the on-chip voltage reference and the temperature supervision comparators are operating in pulsed mode. This reduces the quiescent current of the AS3713 by 45uA (typ.). Because of the pulsed function some specifications are not fulfilled in this mode (e.g. increased noise), but still the full functionality is available.

**Note:** Low power mode can be controlled by the serial interface.

### 9.4.2 Parameter

Table 21. References Parameters

Symbol	Parameter	Note	#Min	Typ	Max	Unit
VCEXT	Reference Voltage	Low noise trimmed voltage reference – connected to Pad CREF; <b>do not load</b>	-1%	1.8	+1%	V
fCLK	Accuracy of Internal reference clock	Adjustable by serial interface register <i>clk_int</i>	-12	fCLK	+12	%

## 9.5 GPIO Pins

### 9.5.1 General Description

The device contains 4 GPIO pins. Each of the pins can be configured as digital input, digital input (with pull-up or pull-down), ADC input (tri-state, or with pull down) only for GPIO2,3 and 4, push-pull output, or open drain output (with or without pull-up). When configured as output the output source can be a register bit, or the PWM generator.

The polarity of the input and output signals can be inverted with the corresponding `gpioX_invert` bit, all further descriptions refer to normal (non-inverted) mode.

Figure 22. GPIO block diagram

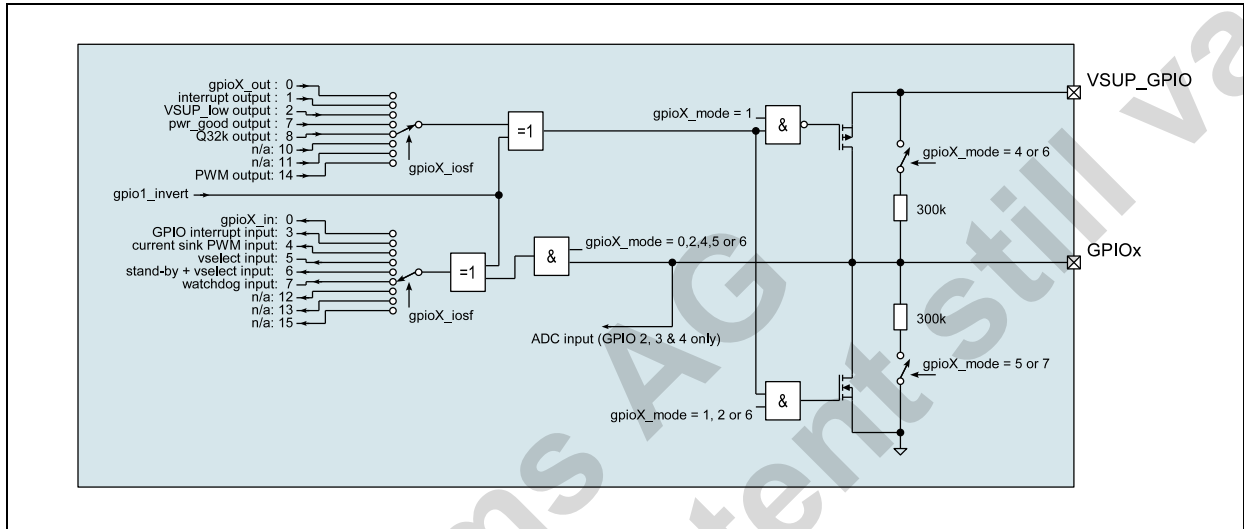

### 9.5.2 IO Functions

#### Normal IO operation:

If set to input, the logic level of the signal present at the GPIOx pin can be read from `gpioX_in`. If the output mode is chosen, `gpioX_out` specifies the logic level of the GPIOx pin.

This mode is also used for the on/off control of the DCDC and LDOs. The selection which regulator is controlled by which GPIO is done with the `gpio_ctrl_sdX` or `gpio_ctrl_ldoX` bits.

This mode is also used for the regulator on/off control by setting the `gpio_ctrl_x` bits. The `gpioX_mode` should be set to input.

#### Interrupt output:

GPIOx pin logic state is derived from the interrupt signal INT. Whenever an interrupt is present the GPIOx pin will be pulled high. The `gpioX_mode` should be set to output.

#### VSUP\_low output

GPIOx pin will go high if VSUP falls below `ResVoltFall` and `SupResEn = 0`. The `gpioX_mode` should be set to output.

#### GPIO interrupt input

A falling or rising edge will set the `gpio_int` bit. The `gpioX_mode` should be set to input.

#### Current sink PWM input

The GPIO is used as PWM input for the current sink to control the current. 100% PWM mode will set the current to the value set `currX_current` register. The PWM control has to be enabled with `currX_ctrl = 11b` for each current sink to be controlled. The `gpioX_mode` should be set to input.

#### Vselect input

As long as the GPIOx pin is high the DCDC/LDOs operate with the normal register settings. If the GPIOx pin goes low the settings will change to the ones stored in `regX_voltage`. The `gpioX_mode` should be set to input.

The regulator effected by this mode is selected by `regX_select`. While GPIO3 & GPIO4 always control all regulators selected by `regX_select`, GPIO1 and GPIO2 may be used to control two regulators separately.:

Table 22. GPIO Vselect modes

gpio1_iosf =	gpio2_iosf =	Vselect mode
<> 5	<> 5	no voltage select by GPIO for regulator
<> 5	5	GPIO2 controls regulator selected by <code>reg1_select</code> , <code>reg2_select</code> and <code>reg3_select</code>
5	<> 5	GPIO1 controls regulator selected by <code>reg1_select</code> , <code>reg2_select</code> and <code>reg3_select</code>
5	5	GPIO1 controls regulator selected by <code>reg1_select</code> GPIO2 controls regulator selected by <code>reg2_select</code>

#### Stand-by and Vselect input

This mode is very similar to the Vselct mode described in the previous paragraph. In addition to switch between 2 register settings of 2 regulators the chip is set into stand-by mode when the GPIOx pin goes low and wakes up again when the pin is pulled high. The `gpioX_mode` should be set to input.

While GPIO3 & GPIO4 always control all regulators selected by `regX_select`, GPIO1 & GPIO2 may be used to control two regulators separately.:

Table 23. GPIO Stand-by plus Vselect modes

gpio1_iosf =	gpio2_iosf =	Vselect mode	stand-by control
<> 6	<> 6	no voltage select by GPIO for regulator	no
<> 6	6	GPIO2 controls regulator selected by <code>reg1_select</code> , <code>reg2_select</code> and <code>reg3_select</code>	yes
6	<> 6	GPIO1 controls regulator selected by <code>reg1_select</code> , <code>reg2_select</code> and <code>reg3_select</code>	yes
6	6	GPIO1 controls regulator selected by <code>reg1_select</code> GPIO2 controls regulator selected by <code>reg2_select</code>	yes

#### PWRGOOD output

This signal will go high at the end of the start-up sequence. This can be used as an second reset signal to the processor to e.g. start oscillators. The `gpioX_mode` should be set to output.

#### Q32k output

When selected the GPIOx will provide the 32kHz RTC crystal frequency. If the oscillator is not enabled or not assembled a internal RC oscillator based clock will be used for the output. The `gpioX_mode` should be set to output.

#### Watchdog input

When pulling the GPIO high the watchdog will be triggered to avoid a reset cycle initiated ba the watchdog. The `gpioX_mode` should be set to input.

#### SU1 OC output

This output signal can be used to control an external disconnect transistor if SU1 detects an over current condition. The `gpioX_mode` should be set to output.

#### PWM output

The gpio block includes an internal programmable PWM generator (can be connected to any of the GPIO outputs). Its timing is defined by `pwm_h_time`, `pwm_l_time` and `pwm_div`. The `gpioX_mode` should be set to output.

### 9.5.3 Parameter

Table 24. GPIO Pin Characteristics

$V_{SUP}=2.7$  to  $5.5V$ ;  $T_{amb}=-20$  to  $+70^{\circ}C$ ; unless otherwise specified

Symbol	Parameter	Note	Min	Typ	Max	Unit
$V_{GPIO_{MAX}}$	Maximum voltage on GPIO1...4 pins	Pin VSUP_GPIO is used as supply for the GPIO pins			$V_{SUP\_GPIO} + 0.3$	V
$V_{OL}$	Low level output voltage	$I_{OL}=+1mA$ ; digital output	-0.3		+0.4	V
$V_{OH}$	High level output voltage	$I_{OH}=-1mA$ ; digital push-pull output	$0.8 \cdot V_{SUP\_GPIO}$		$V_{SUP\_GPIO}$	V
$V_{IL}$	Low level input voltage	digital input	-0.3		0.4	V
$V_{IH}$	High level input voltage	digital input	1.4		$V_{SUP\_GPIO}$	V
$I_{LEAKAGE}$	Leakage current	high impedance			10	$\mu A$
$R_{pull-up}$	Pull-up resistance	if enabled, $V_{SUP\_GPIO}=3.6V$		300		$k\Omega$
$R_{pull-down}$	Pull-down resistance	digital input; if enabled; $V_{SUP\_GPIO}=3.6V$		300		$k\Omega$



## 9.6 Supervisor

All LDO's, the DCDC step ups and DCDC step downs have an integrated over-current protection.

An overtemperature protection of the chip is also integrated which can be switched on with the serial interface signal `temp_pmc_on` (enabled by default; it is not recommended to disable the over-temperature protection).

### 9.6.1 General Description

The chip has two signals for the serial interface: `ov_temp_110` and `ov_temp_140`. The flag `ov_temp_110` is automatically reset if the overtemperature condition is removed, whereas `ov_temp_140` has to be reset by the serial interface with the signal `rst_ov_temp_140`.

If the flag `ov_temp_140` is set, an automatic reset of the complete chip is initiated. The chip will only start-up when the temperature falls below the  $T_{110}$  level (including hysteresis). The flag `ov_temp_140` is not affected by this reset cycle allowing the software to detect the reason for this unexpected shutdown.

Table 25. Over-temperature Detection

Symbol	Parameter	Note	Min	Typ	Max	Unit
$T_{110}$	<code>ov_temp_110</code> rising threshold		95	110	125	°C
$T_{140}$	<code>ov_temp_140</code> rising threshold		125	140	155	°C
$T_{hyst}$	<code>ov_temp_110</code> and <code>ov_temp_140</code> hysteresis			5		°C

## 9.7 Watchdog

### 9.7.1 General Description

The purpose of the watchdog is to detect a deadlock of the software. If the watchdog is active, it must receive a continuous trigger signal within a programmable time window. If there is no signal anymore for a certain time period from a defined pad or special serial interface bit, it starts either a complete reset cycle or changes the state of an output pin, which can be used e.g. as an interrupt to the processor.

- The watchdog is highly configurable by the following register bits:
- The complete block can be switched on by `wtdg_on = 1` and off by `wtdg_on = 0`.
- The watchdog time window is defined by the register `wtdg_min_timer` and `wtdg_max_timer`.
- The trigger signal can be configured by register `wtdg_sw_sig` and `gpio1_iosf` or `gpio4_iosf`.
- If the watchdog expires, the system can start automatically a reset cycle if `wtdg_reset_on = 1`.

### 9.7.2 Parameter

Figure 23. Watchdog timing diagram

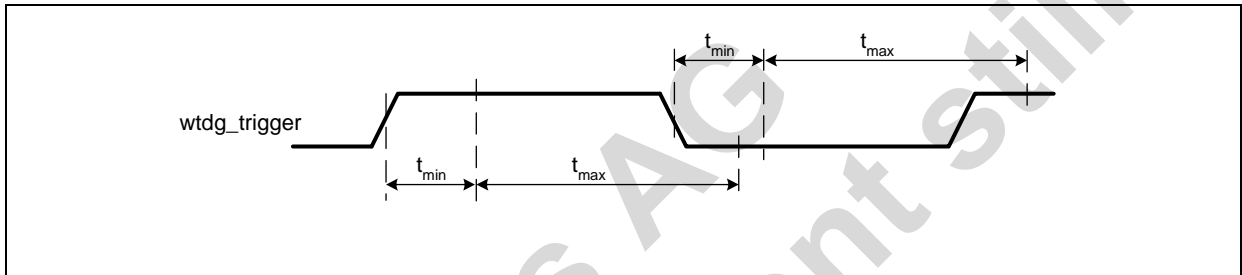

## 9.8 Interrupt Generation

### 9.8.1 General Description

The interrupt controller generates an interrupt request for the host controller as soon as one or more of the bits in the *Interrupt 1...3* register are set by pulling high pin INT (INT has to be selected as a GPIO output function). The output polarity can be changed to active low (XINT) by using the `gpioX_invert` bit of the selected GPIO. All the interrupt sources can be enabled in the Interrupt Mask 1...3 register. The Interrupt 1...3 registers are cleared automatically after the host controller has read them. To prevent the AS3713 device from losing an interrupt event, the register that is read is captured before it is transmitted to the host controller via the serial interface. As soon as the transmission of the captured value is complete a logical AND operation with the bit wise inverted captured value is applied to the register to clear all interrupt bits that have already been transmitted. Clearing the read interrupt bits takes 2 clock cycles, a read access to the same register before the clearing process has completed will yield a value of '0'. Note that an interrupt that has been present at the previous read access will be cleared as well in case it occurs again before the clearing process has completed.

During a read access to one of the interrupt registers the INT pin will be released. As soon as the transferred bits of the interrupt register have been cleared the INT pin will be pulled high in case a new interrupt has occurred in the meantime. By doing so the interrupt controller will work correctly with host controllers that are edge- and level-sensitive on their interrupt request input. Multiple byte read access is recommended to avoid reading the *Interrupt 1* register over and over again in response to a new interrupt that has occurred in the same register (and thus pulling high pin INT) before the Interrupt 2,3 register has been read.

## 9.9 10-Bit ADC

This general purpose ADC can be used for measuring several voltages and currents to perform functions like battery monitor, temperature supervision, button press detection, etc.

### 9.9.1 Input Sources

Table 26. ADC10 Input Sources

#	Source	Range	LSB	Mode	Description
0	ADCIN	1.8V	1.76mV	1:1	
1	DIE temperature	1.8V	1.76mV	1:1	$T_j = (0.866 * ADC10<9:0>) - 274$
2	XOUT32X	1.8V	1.76mV	1:1	
3	CURR1	1.0V	1.76mV	1:1	
4	CURR2	1.0V	1.76mV	1:1	
5	CURR3	1.0V	1.76mV	1:1	
6-8	n.c.	-	-	-	
9	VSUP	5.5V	7.03mV	4:1	check main system supply voltage
A	SENSE_SU1	1.8V / 5.5V	1.76 / 7.03mV	1:1 / 4:1	
B	LX_SD4	1.8V / 5.5V	1.76 / 7.03mV	1:1 / 4:1	
C	GPIO2	1.8V / 5.5V	1.76 / 7.03mV	1:1 / 4:1	
D	GPIO3	1.8V / 5.5V	1.76 / 7.03mV	1:1 / 4:1	
E	GPIO4	1.8V / 5.5V	1.76 / 7.03mV	1:1 / 4:1	
F					reserved

### 9.9.2 Parameter

Table 27. ADC Characteristics

Symbol	Parameter	Note	Min	Typ	Max	Unit
Resolution			10			Bit
Input Voltage Range	V <sub>in</sub>	for 1:1 mode	0		1.8	V
Differential Nonlinearity	DNL	1LSB 1.76mV for 1:1 (depending on selected channel)		± 0.25		LSB
Integral Nonlinearity	INL			± 0.5		LSB
Input Offset Voltage	V <sub>os</sub>			2		LSB
Input Impedance	R <sub>in</sub>		100			MΩ
Input Capacitance	C <sub>in</sub>				9	pF
Power Supply Current	I <sub>dd</sub>	during conversion only		500		μA
Power Down Current	I <sub>dd</sub>			100		nA
<b>Transient Parameters (25°C)</b>						
Conversion Time	T <sub>c</sub>			40		μs
Clock Frequency	f <sub>c</sub>	internal CLK frequency/8		f <sub>clk_int</sub> /8		kHz
Settling time of S&H	t <sub>s</sub>		1			μs

Figure 24. ADC Timing-diagram

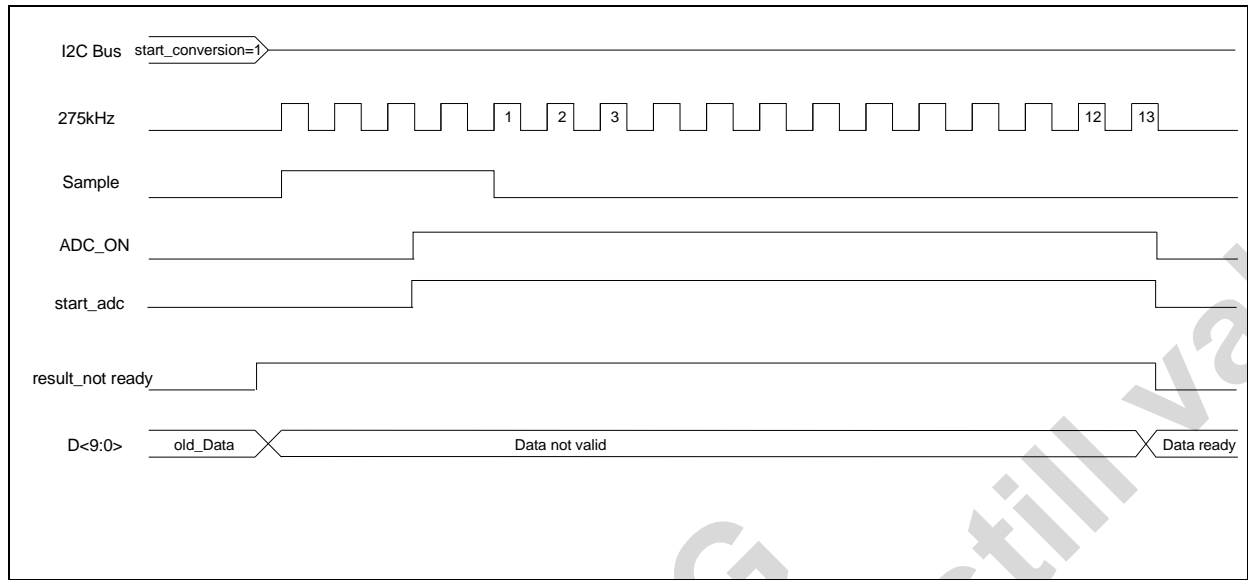

## 9.10 Real Time Clock

### 9.10.1 General Description

The RTC module provides time information to the system. It is implemented as a 6-bit counter that is incremented every second - with the 32kHz oscillator delivering the necessary accurate time base – and is reset to 0 each time the counter value is 60. An additional 24-bit minute counter is incremented each time the 6-bit counter is reset to 0. Both counters are set to 0 at a power-on-reset. The host controller can set the counter to any value by setting the RTC 1...4 registers.

To prevent ambiguous time information because of the 30-bit value being incremented before all of the 4 registers have been read or written, a 30-bit parallel shadow register is implemented. Every time a write/read access via the serial interface occurs the parallel shadow register is updated with the current value of the 30-bit counter. Any write access to the RTCSecond register will disable the update of the parallel register and set the value of the appropriate byte of the parallel register. Any subsequent write access to the RTCMinute3 register will transfer the current value of the 30-bit parallel register to the RTCSecond/Minute1..3 registers and the update of the parallel register is enabled again. Similarly, any read access to the RTCSecond register will freeze the current value of the parallel register and submit the appropriate byte to the host controller via the serial interface. Any subsequent read access to the RTCMinute3 register will enable the update of the parallel register again. This mechanism makes sure that the maximum error of the value that is written to or read from the registers is 1 second.

To start the RTC, rtc\_on bit has to be set to 1.

The RTC stops automatically at its highest value (3F,FF,FF,FF) to prevent overrun.

### 9.10.2 Alarm

The RTC module includes an alarm function. When the content of the RTCAlarm registers equals the content of the RTC registers bit rtc\_alarm will be set in the interrupt register. Furthermore the RTC module can generate a repeating interrupt every second, every minute, every 2 minutes or every 8 minutes.

To avoid ambiguous behavior during write access to the RTCAlarm registers any write access to the RTCAlarmSecond register will disable the alarm function; any subsequent write access to the RTCAlarmMinute3 will enable the alarm function again.

## 9.11 2-Wire-Serial Control Interface

### 9.11.1 Feature List

- Fast-mode capability (max. SCL-frequency is 400 kHz)
- 7+1-bit addressing mode
- 60h x 8-bit data registers (word address 0x00 - 0x60)
- Write formats: Single-Byte-Write, Page-Write
- Read formats: Current-Address-Read, Random-Read, Sequential-Read
- SDA input delay and SCL spike filtering by integrated RC-components

### 9.11.2 Protocol

Table 28. 2-Wire Serial Symbol Definition

Symbol	Definition	RW	Note
S	Start condition after stop	R	1 bit
Sr	Repeated start	R	1 bit
DW	Device address for write	R	1000 0000b (80h)
DR	Device address for read	R	1000 0001b (81h)
WA	Word address	R	8 bit
A	Acknowledge	W	1 bit
N	No Acknowledge	R	1 bit
reg_data	Register data/write	R	8 bit
data (n)	Register data/read	W	8 bit
P	Stop condition	R	1 bit
WA++	Increment word address internally	R	during acknowledge

Figure 25. Byte Write

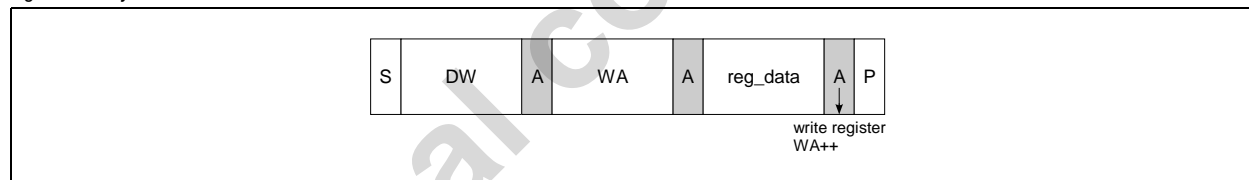
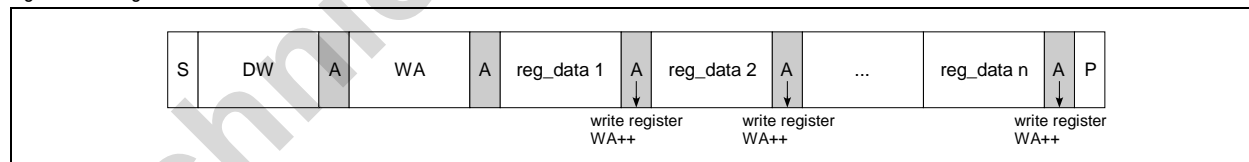

Figure 26. Page Write



Byte Write and Page Write formats are used to write data to the slave.

The transmission begins with the START condition, which is generated by the master when the bus is in IDLE state (the bus is free). The device-write address is followed by the word address. After the word address any number of data bytes can be sent to the slave. The word address is incremented internally, in order to write subsequent data bytes on subsequent address locations.

For reading data from the slave device, the master has to change the transfer direction. This can be done either with a repeated START condition followed by the device-read address, or simply with a new transmission START followed by the device-read address, when the bus is in IDLE state. The device-read address is always followed by the 1st register byte transmitted from the slave. In Read Mode any number of subsequent register bytes can be read from the slave. The word address is incremented internally.

Figure 27. Random Read

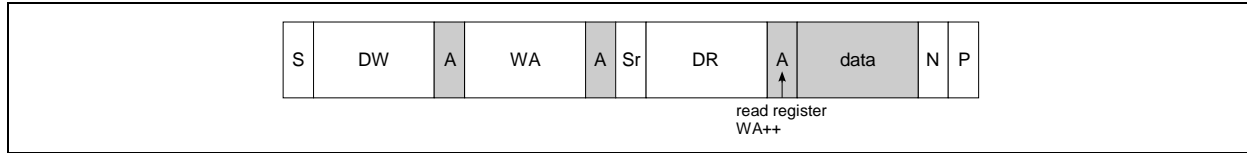

Random Read and Sequential Read are combined formats. The repeated START condition is used to change the direction after the data transfer from the master.

The word address transfer is initiated with a START condition issued by the master while the bus is idle. The START condition is followed by the device-write address and the word address.

In order to change the data direction a repeated START condition is issued on the 1st SCL pulse after the acknowledge bit of the word address transfer. After the reception of the device-read address, the slave becomes the transmitter. In this state the slave transmits register data located by the previous received word address vector. The master responds to the data byte with a not-acknowledge, and issues a STOP condition on the bus.

Figure 28. Sequential Read

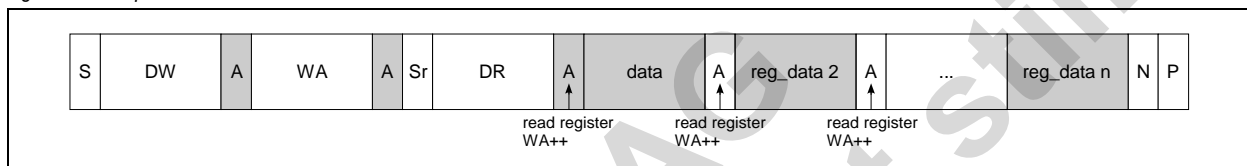

Sequential Read is the extended form of Random Read, as more than one register-data bytes are transferred subsequently. In difference to the Random Read, for a sequential read the transferred register-data bytes are responded by an acknowledge from the master. The number of data bytes transferred in one sequence is unlimited (consider the behavior of the word-address counter). To terminate the transmission the master has to send a not-acknowledge following the last data byte and generate the STOP condition subsequently.

Figure 29. Current Address Read

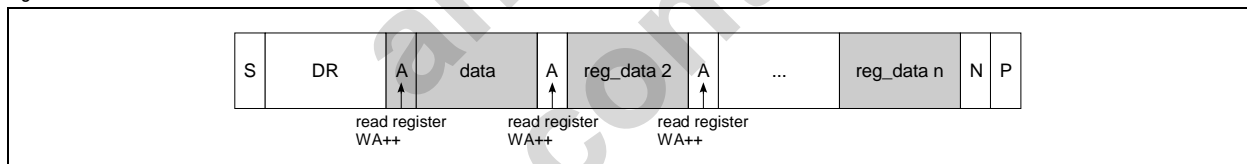

To keep the access time as small as possible, this format allows a read access without the word address transfer in advance to the data transfer. The bus is idle and the master issues a START condition followed by the Device-Read address. Analogous to Random Read, a single byte transfer is terminated with a not-acknowledge after the 1st register byte. Analogous to Sequential Read an unlimited number of data bytes can be transferred, where the data bytes has to be responded with an acknowledge from the master. For termination of the transmission the master sends a not-acknowledge following the last data byte and a subsequent STOP condition.

### 9.11.3 Parameter

Table 29. I2C SDA,SCL Characteristics

Symbol	Parameter	Note	Min	Typ	Max	Unit
$V_{IL}$	SCL,SDA Low Level input voltage		-0.3		0.4	V
$V_{IH}$	SCL,SDA High Level input voltage		1.4		VSUP_G PIO	V

The AS3713 is compatible to the NXP two wire specification [http://www.nxp.com/acrobat\\_download2/literature/9398/39340011.pdf](http://www.nxp.com/acrobat_download2/literature/9398/39340011.pdf) Version 2.1 January 2000 for standard and fast mode (no high speed mode).



## 10 Register Overview

Table 30. Register Overview

Addr	Name	<D7>	<D6>	<D5>	<D4>	<D3>	<D2>	<D1>	<D0>	
00h	SD1Voltage	sd1_frequ	sd1_vsel<6:0>							
01h	SD2Voltage	sd2_frequ	sd2_vsel<6:0>							
02h	SD3Voltage	sd3_frequ	sd3_vsel<6:0>							
03h	SD4Voltage		sd4_vsel<6:0>							
04h	LDO1Voltage	ldo1_on	ldo1_ilimit	-	ldo1_vsel<4:0>					
05h	LDO2Voltage	ldo2_on	ldo2_ilimit	-	ldo2_vsel<4:0>					
06h	LDO3Voltage	ldo3_on	ldo3_ilimit	ldo3_vsel<5:0>						
07h	LDO4Voltage	ldo4_on	ldo4_ilimit	ldo4_vsel<5:0>						
08h	LDO5Voltage	ldo5_on	ldo5_ilimit	ldo5_vsel<5:0>						
09h	LDO6Voltage	ldo6_on	ldo6_ilimit	ldo6_vsel<5:0>						
0ah	LDO7Voltage	ldo7_on	ldo7_ilimit	ldo7_vsel<5:0>						
0bh	LDO8Voltage	ldo8_on	ldo8_ilimit	ldo8_vsel<5:0>						
0ch	GPIO1control	gpio1_invert	gpio1_iosf<6:3>			gpio1_mode<2:0>				
0dh	GPIO2control	gpio2_invert	gpio2_iosf<6:3>			gpio2_mode<2:0>				
0eh	GPIO3control	gpio3_invert	gpio3_iosf<6:3>			gpio3_mode<2:0>				
0fh	GPIO4control	gpio4_invert	gpio4_iosf<6:3>			gpio4_mode<2:0>				
10h	SD_control		-	sd4_enable		sd3_enable	sd2_enable	sd1_enable		
20h	GPIOsignal_out		-	gpio4_out		gpio3_out	gpio2_out	gpio1_out		
21h	GPIOsignal_in		-	gpio4_in		gpio3_in	gpio2_in	gpio1_in		
22h	Reg1_Voltage	reg1_voltage<7:0>								
23h	Reg2_Voltage	reg2_voltage<7:0>								
24h	Reg_control	reg2_select<7:4>				reg1_select<3:0>				
25h	GPIOctrl_sd	gpio_ctrl_sd4<7:6>		gpio_ctrl_sd3<5:4>		gpio_ctrl_sd2<3:2>		gpio_ctrl_sd1<1:0>		
26h	GPIOctrl_ldo1	gpio_ctrl_ldo4<7:6>		gpio_ctrl_ldo3<5:4>		gpio_ctrl_ldo2<3:2>		gpio_ctrl_ldo1<1:0>		
27h	GPIOctrl_ldo2	gpio_ctrl_ldo8<7:6>		gpio_ctrl_ldo7<5:4>		gpio_ctrl_ldo6<3:2>		gpio_ctrl_ldo5<1:0>		
2bh	Reg3_Voltage	reg3_voltage<7:0>								

Table 30. Register Overview

Addr	Name	<D7>	<D6>	<D5>	<D4>	<D3>	<D2>	<D1>	<D0>	
2ch	Reg_control3	-				reg3_select<3:0>				
30h	SD_control1	sd4_low_noise	sd3_low_noise	sd2_low_noise	sd1_low_noise	sd4_fast	sd3_fast	sd2_fast	sd1_fast	
31h	SD_control2	sd_dvm_select<7:6>		dvm_time<5:4>		sd3_slave	sd3_fsel	sd2_fsel	sd1_fsel	
32h	Battery_voltage_monitor	FastResEn	SupResEn	ResVoltFall<5:3>			ResVoltRise<2:0>			
33h	Startup_Control	-							power_off_at_vsop low	
34h	ResetTimer	-	stby_reset_disabl e	auto_off	off_delay<4:3>		-	res_timer<1:0>		
35h	ReferenceControl	on_reset_delay	reg_low_bias_mo de	clk_div2	standby_mode_on	clk_int<3:1>			low_power_on	
36h	ResetControl	onkey_reset	reset_reason<6:3>				on_input	power_off	force_reset	
37h	OvertemperatureControl					rst_ov_temp_140	ov_temp_140	ov_temp_110	temp_pmc_on	
38h	WatchdogControl	-							wtdg_res_on	wtdg_on
39h	Reg_standby_mod1	disable_regpd	-			sd4_stby_on	sd3_stby_on	sd2_stby_on	sd1_stby_on	
3ah	Reg_standby_mod2	ldo8_stby_on	ldo7_stby_on	ldo6_stby_on	ldo5_stby_on	ldo4_stby_on	ldo3_stby_on	ldo2_stby_on	ldo1_stby_on	
40h	curr_control	curr3_ctrl<7:4>				curr2_ctrl<3:2>		curr1_ctrl<1:0>		
41h	pwm_control_l	pwm_l_time<7:0>								
42h	pwm_control_h	pwm_h_time<7:0>								
43h	curr1_value	curr1_current<7:0>								
44h	curr2_value	curr2_current<7:0>								
45h	curr3_value	curr3_current<7:0>								
46h	Watchdog_min_timer	wtdg_min_timer<7:0>								
47h	Watchdog_max_timer	wtdg_max_timer<7:0>								
48h	WatchdogSoftwareSignal	pwm_div<7:6>		-					wtdg_sw_sig	
50h	Stepup_control1	stepup1_v<7:3>					stepup1_res	stepup1_freq	stepup1_on	
51h	Stepup_control2	stepup2_v<7:3>					stepup2_res	stepup2_freq	stepup2_on	
53h	Stepup_control4	stpup1_det	stpup1_oc	stpup1_oc_timeout	stpup1_shortprot	stpup2_pwm_lowf	stepup2_prot_dis	stepup2_fb<1:0>		
54h	Stepup_control5	-					stepup2_pwm_mod e	stepup12_clkinv	stepup2_fbprot<1:0>	

Table 30. Register Overview

Addr	Name	<D7>	<D6>	<D5>	<D4>	<D3>	<D2>	<D1>	<D0>	
60h	RTCcontrol	-			rtc_irq_mode<4:3>		rtc_on	rtc_alarm_wakeup_en	rtc_rep_wakeup_en	
61h	RTCSecond	second<7:0>								
62h	RTCMinute1	minute0<7:0>								
63h	RTCMinute2	minute1<7:0>								
64h	RTCMinute3	minute2<7:0>								
65h	RTCAlarmSecond	alarmsecond<7:0>								
66h	RTCAlarmMinute1	alarmminute0<7:0>								
67h	RTCAlarmMinute2	alarmminute1<7:0>								
68h	RTCAlarmMinute3	alarmminute2<7:0>								
69h	SRAM	SRAM<7:0>								
70h	ADC_control	start_conversion	adc_on	adc_slow	gpio_lv	adc_select<3:0>				
71h	ADC_MSB_result	result_not_ready	D9_3<6:0>							
72h	ADC_LSB_result	-					D2_0<2:0>			
73h	RegStatus	curr3_lv	curr2_lv	curr1_lv	-	sd4_lv	sd3_lv	sd2_lv	sd1_lv	
74h	InterruptMask1	LowBat_int_m	ovtmp_int_m	onkey_int_m	chdet_int_m	eoc_int_m	resume_int_m	nobat_int_m	trickle_int_m	
75h	InterruptMask2	rtc_rep_int_m	stpup1_det_m	stpup1_oc_m	bat_temp_m	sd4_lv_int_m	sd3_lv_int_m	sd2_lv_int_m	sd1_lv_int_m	
76h	InterruptMask3	-					gpio_restart_int_m	gpio_int_m	rtc_alarm_int_m	
77h	InterruptStatus1	LowBat_int_i	ovtmp_int_i	onkey_int_i	chdet_int_i	eoc_int_i	resume_int_i	nobat_int_i	trickle_int_i	
78h	InterruptStatus2	rtc_rep_int_i	stpup1_det_i	stpup1_oc_i	bat_temp_i	sd4_lv_int_i	sd3_lv_int_i	sd2_lv_int_i	sd1_lv_int_i	
79h	InterruptStatus3	-					gpio_restart_int_i	gpio_int_i	rtc_alarm_int_i	
8eh	LockRegister	-							reg_lock<1:0>	
90h	ASIC_ID1	ID1<7:0>								
91h	ASIC_ID2	-					revision<3:0>			

**SD1Voltage Register (Address 00h).**

Addr: 00h		SD1Voltage		
Bit	Bit Name	Default	Access	Bit Description
7	sd1_frequ	0	RW	Selects between high and low frequency dependent on sd1_fsel <b>0</b> : 2MHz if <b>sd1_fsel=0</b> , 3MHz if <b>sd1_fsel=1</b> <b>1</b> : 3MHz if <b>sd1_fsel=0</b> , 4MHz if <b>sd1_fsel=1</b>
6:0	sd1_vsel	'b0000000	RW	The voltage select bits set the DC/DC output voltage level and power the DC/DC converter down. <b>00h</b> : DC/DC powered down <b>01h-40h</b> : $V_{SD1}=0.6V+sd1\_vsel*12.5mV$ <b>41h-70h</b> : $V_{SD1}=1.4V+(sd1\_vsel-40h)*25mV$ <b>71h-7Fh</b> : $V_{SD1}=2.6V+(sd1\_vsel-70h)*50mV$

**SD2Voltage Register (Address 01h).**

Addr: 01h		SD2Voltage		
Bit	Bit Name	Default	Access	Bit Description
7	sd2_frequ	0	RW	Selects between high and low frequency dependent on sd2_fsel <b>0</b> : 2MHz if <b>sd2_fsel=0</b> , 3MHz if <b>sd2_fsel=1</b> <b>1</b> : 3MHz if <b>sd2_fsel=0</b> , 4MHz if <b>sd2_fsel=1</b>
6:0	sd2_vsel	'b000 0000	RW	The voltage select bits set the DC/DC output voltage level and power the DC/DC converter down. <b>00h</b> : DC/DC powered down <b>01h-40h</b> : $V_{SD2}=0.6V+sd2\_vsel*12.5mV$ <b>41h-70h</b> : $V_{SD2}=1.4V+(sd2\_vsel-40h)*25mV$ <b>71h-7Fh</b> : $V_{SD2}=2.6V+(sd2\_vsel-70h)*50mV$

**SD3Voltage Register (Address 02h).**

Addr: 02h		SD3Voltage		
Bit	Bit Name	Default	Access	Bit Description
7	sd3_frequ	0	RW	Selects between high and low frequency dependent on sd3_fsel <b>0</b> : 2MHz if <b>sd3_fsel=0</b> , 3MHz if <b>sd3_fsel=1</b> <b>1</b> : 3MHz if <b>sd3_fsel=0</b> , 4MHz if <b>sd3_fsel=1</b>
6:0	sd3_vsel	'b000 0000	RW	The voltage select bits set the DC/DC output voltage level and power the DC/DC converter down. <b>00h</b> : DC/DC powered down <b>01h-40h</b> : $V_{SD3}=0.6V+sd3\_vsel*12.5mV$ <b>41h-70h</b> : $V_{SD3}=1.4V+(sd3\_vsel-40h)*25mV$ <b>71h-7Fh</b> : $V_{SD3}=2.6V+(sd3\_vsel-70h)*50mV$

**SD4Voltage Register (Address 03h).**

Addr: 03h		SD4Voltage		
Bit	Bit Name	Default	Access	Bit Description
7	-	0	RW	-
6:0	sd4_vsel	'b000 0000	RW	The voltage select bits set the DC/DC output voltage level and power the DC/DC converter down. <b>00h</b> : DC/DC powered down <b>01h-40h</b> : $V_{SD4}=0.6V+sd4\_vsel*12.5mV$ <b>41h-70h</b> : $V_{SD4}=1.4V+(sd4\_vsel-40h)*25mV$ <b>71h-7Fh</b> : $V_{SD4}=2.6V+(sd4\_vsel-70h)*50mV$

**LDO1Voltage Register (Address 04h).**

Addr: 04h		LDO1Voltage		
Bit	Bit Name	Default	Access	Bit Description
7	ldo1_on	0	RW	Switch on of LDO1 <b>0</b> : LDO off <b>1</b> : LDO on
6	ldo1_ilimit	0	RW	Sets limit of LDO1 <b>0</b> : 150mA limit <b>1</b> : 250mA limit
4:0	ldo1_vsel	'b0 0000	RW	The voltage select bits set the LDO output voltage <b>0h-0Fh</b> : $1.2V + ldo1\_vsel*50mV$ <b>10h-1Fh</b> : $1.8V + (ldo1\_vsel-16)*100mV$

**LDO2Voltage Register (Address 05h).**

Addr: 05h		LDO2Voltage		
Bit	Bit Name	Default	Access	Bit Description
7	ldo2_on	0	RW	Switch on of LDO2 <b>0</b> : LDO off <b>1</b> : LDO on
6	ldo2_ilimit	0	RW	Sets limit of LDO2 <b>0</b> : 150mA limit <b>1</b> : 250mA limit
4:0	ldo2_vsel	'b0 0000	RW	The voltage select bits set the LDO output voltage <b>0h-0Fh</b> : $1.2V + ldo2\_vsel*50mV$ <b>10h-1Fh</b> : $1.8V + (ldo2\_vsel-16)*100mV$

**LDO3Voltage Register (Address 06h).**

Addr: 06h		LDO3Voltage		
Bit	Bit Name	Default	Access	Bit Description
7	ldo3_on	0	RW	Switch on of LDO3 0 : LDO off 1 : LDO on
6	ldo3_ilimit	0	RW	Sets limit of LDO3 0 : 150mA operating range 1 : 300mA operating range
5:0	ldo3_vsel	'b00 0000	RW	The voltage select bits set the LDO output voltage 00h-10h : $V\_LDO3=0.9V+ldo3\_vsel*50mV$ 11h-1fh : do not use 20h-3Fh : $V\_LDO3=1.75V+(ldo3\_vsel-20h)*50mV$

**LDO4Voltage Register (Address 07h).**

Addr: 07h		LDO4Voltage		
Bit	Bit Name	Default	Access	Bit Description
7	ldo4_on	0	RW	Switch on of LDO4 0 : LDO off 1 : LDO on
6	ldo4_ilimit	0	RW	Sets limit of LDO4 0 : 150mA operating range 1 : 300mA operating range
5:0	ldo4_vsel	'b00 0000	RW	The voltage select bits set the LDO output voltage 00h-10h : $V\_LDO4=0.9V+ldo4\_vsel*50mV$ 11h-1fh : Do not use 20h-3Fh : $V\_LDO4=1.75V+(ldo4\_vsel-20h)*50mV$

**LDO5Voltage Register (Address 08h).**

Addr: 08h		LDO5Voltage		
Bit	Bit Name	Default	Access	Bit Description
7	ldo5_on	0	RW	Switch on of LDO5 0 : LDO off 1 : LDO on
6	ldo5_ilimit	0	RW	Sets limit of LDO5 0 : 150mA operating range 1 : 300mA operating range
5:0	ldo5_vsel	'b00 0000	RW	The voltage select bits set the LDO output voltage 00h-10h : $V\_LDO5=0.9V+ldo5\_vsel*50mV$ 11h-1fh : Do not use 20h-3Fh : $V\_LDO5=1.75V+(ldo5\_vsel-20h)*50mV$

**LDO6Voltage Register (Address 09h).**

Addr: 09h		LDO6Voltage		
Bit	Bit Name	Default	Access	Bit Description
7	ldo6_on	0	RW	Switch on of LDO6 0 : LDO off 1 : LDO on
6	ldo6_ilimit	0	RW	Sets limit of LDO6 0 : 150mA operating range 1 : 300mA operating range
5:0	ldo6_vsel	'b00 0000	RW	The voltage select bits set the LDO output voltage 00h-10h : $V\_LDO6=0.9V+ldo6\_vsel*50mV$ 11h-1fh : Do not use 20h-3Fh : $V\_LDO6=1.75V+(ldo6\_vsel-20h)*50mV$

**LDO7Voltage Register (Address 0ah).**

Addr: 0ah		LDO7Voltage		
Bit	Bit Name	Default	Access	Bit Description
7	ldo7_on	0	RW	Switch on of LDO7 0 : LDO off 1 : LDO on
6	ldo7_ilimit	0	RW	Sets limit of LDO7 0 : 150mA operating range 1 : 300mA operating range
5:0	ldo7_vsel	'b00 0000	RW	The voltage select bits set the LDO output voltage 00h-10h : $V\_LDO7=0.9V+ldo7\_vsel*50mV$ 11h-1fh : Do not use 20h-3Fh : $V\_LDO7=1.75V+(ldo7\_vsel-20h)*50mV$

**LDO8Voltage Register (Address 0bh).**

Addr: 0bh		LDO8Voltage		
Bit	Bit Name	Default	Access	Bit Description
7	ldo8_on	0	RW	Switch on of LDO8 0 : LDO off 1 : LDO on
6	ldo8_ilimit	0	RW	Sets limit of LDO8 0 : 150mA operating range 1 : 300mA operating range
5:0	ldo8_vsel	'b00 0000	RW	The voltage select bits set the LDO output voltage 00h-10h : $V\_LDO8=0.9V+ldo8\_vsel*50mV$ 11h-1fh : Do not use 20h-3Fh : $V\_LDO8=1.75V+(ldo8\_vsel-20h)*50mV$

**GPIO1control Register (Address 0ch).**

Addr: 0ch		GPIO1control		
Bit	Bit Name	Default	Access	Bit Description
7	gpio1_invert	0	RW	Invert GPIO input/output <b>0</b> : Normal mode <b>1</b> : Invert input or output
6:3	gpio1_iosf	'b0000	RW	Select the GPIO special function <b>0</b> : Normal I/O operation <b>1</b> : Interrupt output <b>2</b> : VSUP_low output <b>3</b> : GPIO interrupt input <b>4</b> : Current sink PWM input <b>5</b> : Vselect input, (apply on <b>reg1_select</b> , <b>reg2_select</b> and <b>reg3_select</b> , if <b>gpio2_iosf</b> =5 then apply on <b>reg1_select</b> only) <b>6</b> : standby + Vselect + restart interrupt input <b>7</b> : pwr_good output <b>8</b> : Q32k output (if osc_pd=1 then internal RC oscillator with 32kHz divider is used) <b>9</b> : Watchdog input <b>14</b> : PWM output
2:0	gpio1_mode	'b011	RW	Selects the GPIO mode (I, I/O, Tri, Pulls) <b>0</b> : Input <b>1</b> : Output (push and pull) <b>2</b> : IO (open drain, only NMOS is active) <b>3</b> : Tristate <b>4</b> : Input with pullup <b>5</b> : Input with pulldown <b>6</b> : IO (open drain (NMOS) with pullup) <b>7</b> : n/a



**GPIO2control Register (Address 0dh).**

Addr: 0dh		GPIO2control		
Bit	Bit Name	Default	Access	Bit Description
7	gpio2_invert	0	RW	Invert GPIO input/output <b>0</b> : Normal mode <b>1</b> : Invert input or output
6:3	gpio2_iosf	'b0000	RW	Select the GPIO special function <b>0</b> : Normal i/o operation <b>1</b> : Interrupt output <b>2</b> : VSUP_low output <b>3</b> : GPIO interrupt input <b>4</b> : Current sink PWM input <b>5</b> : Vselect input, (apply on <b>reg1_select</b> , <b>reg2_select</b> and <b>reg3_select</b> , if <b>gpio1_iosf</b> =5 then apply on <b>reg2_select</b> and <b>reg3_select</b> only) <b>6</b> : standby + Vselect + restart interrupt input <b>7</b> : pwr_good output <b>8</b> : Q32k output (if <b>osc_pd</b> =1 then internal RC oscillator with 32kHz divider is used) <b>9</b> : Stepup1 over-current output <b>14</b> : PWM output
2:0	gpio2_mode	'b011	RW	Selects the GPIO mode (I, I/O, Tri, Pulls) <b>0</b> : Input <b>1</b> : Output (push and pull) <b>2</b> : IO (open drain, only NMOS is active) <b>3</b> : ADC input (tristate) <b>4</b> : Input with pullup <b>5</b> : Input with pulldown <b>6</b> : IO (open drain (NMOS) with pullup) <b>7</b> : ADC input with pulldown

**GPIO3control Register (Address 0eh).**

Addr: 0eh		GPIO3control		
Bit	Bit Name	Default	Access	Bit Description
7	gpio3_invert	0	RW	Invert GPIO input/output <b>0</b> : Normal mode <b>1</b> : Invert input or output
6:3	gpio3_iosf	'b0000	RW	Select the GPIO special function <b>0</b> : Normal i/o operation <b>1</b> : Interrupt output <b>2</b> : VSUP_low output <b>3</b> : GPIO interrupt input <b>4</b> : Currentsink PWM input <b>5</b> : Vselect input, (apply on <b>reg1_select</b> , <b>reg2_select</b> and <b>reg3_select</b> ) <b>6</b> : standby + Vselect + restart interrupt input <b>7</b> : pwr_good output <b>8</b> : Q32k output (if osc_pd=1 then internal RC oscillator with 32kHz divider is used) <b>9</b> : Stepup1 over-current output <b>14</b> : PWM output
2:0	gpio3_mode	'b011	RW	Selects the GPIO mode (I, I/O, Tri, Pulls) <b>0</b> : Input <b>1</b> : Output (push and pull) <b>2</b> : IO (open drain, only NMOS is active) <b>3</b> : ADC input (tristate) <b>4</b> : Input with pullup <b>5</b> : Input with pulldown <b>6</b> : IO (open drain (NMOS) with pullup) <b>7</b> : ADC input with pulldown

**GPIO4control Register (Address 0fh).**

Addr: 0fh		GPIO4control		
Bit	Bit Name	Default	Access	Bit Description
7	gpio4_invert	0	RW	Invert GPIO input/output 0 : Normal mode 1 : Invert input or output
6:3	gpio4_iosf	'b0000	RW	Select the GPIO special function 0 : Normal i/o operation 1 : Interrupt output 2 : VSUP_low output 3 : GPIO interrupt input 4 : Currentsink PWM input 5 : Vselect input, (apply on <b>reg1_select</b> , <b>reg2_select</b> and <b>reg3_select</b> ) 6 : standby + Vselect + restart interrupt input 7 : pwr_good output 8 : Q32k output (if osc_pd=1 then internal RC oscillator with 32kHz divider is used) 9 : Watchdog input 14 : PWM output
2:0	gpio4_mode	'b011	RW	Selects the GPIO mode (I, I/O, Tri, Pulls) 0 : Input 1 : Output (push and pull) 2 : IO (open drain, only NMOS is active) 3 : ADC input (tristate) 4 : Input with pullup 5 : Input with pulldown 6 : IO (open drain (NMOS) with pullup) 7 : ADC input with pulldown

**SD\_control Register (Address 10h).**

Addr: 10h		SD_control		
Bit	Bit Name	Default	Access	Bit Description
7:4	-	'b0000	n/a	do not use
3	sd4_enable	'b1	RW	Global stepdown4 enable 0 : SD4 off 1 : SD4 on
2	sd3_enable	'b1	RW	Global stepdown3 enable 0 : SD3 off 1 : SD3 on
1	sd2_enable	'b1	RW	Global stepdown2 enable 0 : SD2 off 1 : SD2 on
0	sd1_enable	'b1	RW	Global stepdown1 enable 0 : SD1 off 1 : SD1 on

**GPIOsignal\_out Register (Address 20h).**

Addr: 20h		GPIOsignal_out		
Bit	Bit Name	Default	Access	Bit Description
7:4	-	'b0000	n/a	do not use
3	gpio4_out	0	RW	This bit determines the output signal of the GPIO4 pin when selected as output source.
2	gpio3_out	0	RW	This bit determines the output signal of the GPIO3 pin when selected as output source.
1	gpio2_out	0	RW	This bit determines the output signal of the GPIO2 pin when selected as output source.
0	gpio1_out	0	RW	This bit determines the output signal of the GPIO1 pin when selected as output source.

**GPIOsignal\_in Register (Address 21h).**

Addr: 21h		GPIOsignal_in		
Bit	Bit Name	Default	Access	Bit Description
7:4	-	'b0000	n/a	do not use
3	gpio4_in	0	RO	This bit reflects the logic level of the GPIO4 pin when configured as digital input pin.
2	gpio3_in	0	RO	This bit reflects the logic level of the GPIO3 pin when configured as digital input pin.
1	gpio2_in	0	RO	This bit reflects the logic level of the GPIO2 pin when configured as digital input pin.
0	gpio1_in	0	RO	This bit reflects the logic level of the GPIO1 pin when configured as digital input pin.

**Reg1\_Voltage Register (Address 22h).**

Addr: 22h		Reg1_Voltage		
Bit	Bit Name	Default	Access	Bit Description
7:0	reg1_voltage	'b0000 0000	RW	This register is mapped to the register address 0h+Reg1_select , if gioX_iosf = 5 or 6 (Vselect input), and the GPIOx input = 1. This feature allows voltage switching of a predefined regulator with just one GPIO input. <b>0 ..FFh</b> : Selects voltage, ilimit, on or frequency bits of LDO or DCDC

**Reg2\_Voltage Register (Address 23h).**

Addr: 23h		Reg2_Voltage		
Bit	Bit Name	Default	Access	Bit Description
7:0	reg2_voltage	'b0000 0000	RW	This register is mapped to the register address 0h+Reg3_select , if gioX_iosf=5 or 6 (Vselect input), and GPIOx input = 1, This feature allows voltage switching of a predefined regulator with just one GPIO input <b>0 ..FFh</b> : Selects voltage, ilimit, on or frequency bits of LDO or DCDC

**Reg\_control Register (Address 24h).**

Addr: 24h		Reg_control		
Bit	Bit Name	Default	Access	Bit Description
7:4	reg2_select	'b1111	RW	Selects regulator for mapping feature; if reg_select2 ≥ 0Ch, then feature is disabled.
3:0	reg1_select	'b1111	RW	Selects regulator for mapping feature; if reg_select1 ≥ 0Ch, then feature is disabled.

**GPIOctrl\_sd Register (Address 25h).**

Addr: 25h		GPIOctrl_sd		
Bit	Bit Name	Default	Access	Bit Description
7:6	gpio_ctrl_sd4	'b00	RW	Enable GPIO control of DCDC SD4. GPIO ctrl only enabled, if <b>sd4_vsel</b> > 0 <b>0</b> : No GPIO control <b>1</b> : Controlled by GPIO1 <b>2</b> : Controlled by GPIO2 <b>3</b> : Controlled by GPIO3
5:4	gpio_ctrl_sd3	'b00	RW	Enable GPIO control of DCDC SD3. GPIO ctrl only enabled, if <b>sd3_vsel</b> > 0 <b>0</b> : No GPIO control <b>1</b> : Controlled by GPIO1 <b>2</b> : Controlled by GPIO2 <b>3</b> : Controlled by GPIO3
3:2	gpio_ctrl_sd2	'b00	RW	Enable GPIO control of DCDC SD2. GPIO ctrl only enabled, if <b>sd2_vsel</b> > 0 <b>0</b> : No GPIO control <b>1</b> : Controlled by GPIO1 <b>2</b> : Controlled by GPIO2 <b>3</b> : Controlled by GPIO3
1:0	gpio_ctrl_sd1	'b00	RW	Enable GPIO control of DCDC SD1. GPIO ctrl only enabled, if <b>sd1_vsel</b> > 0 <b>0</b> : No GPIO control <b>1</b> : Controlled by GPIO1 <b>2</b> : Controlled by GPIO2 <b>3</b> : Controlled by GPIO3

**GPIOctrl\_Ido1 Register (Address 26h).**

Addr: 26h		GPIOctrl_Ido1		
Bit	Bit Name	Default	Access	Bit Description
7:6	gpio_ctrl_ido4	'b00	RW	Enable GPIO control of LDO4. GPIO ctrl only enabled, if <b>Ido4_on</b> = 1 <b>0</b> : No GPIO control <b>1</b> : Controlled by GPIO1 <b>2</b> : Controlled by GPIO2 <b>3</b> : Controlled by GPIO3
5:4	gpio_ctrl_ido3	'b00	RW	Enable GPIO control of LDO3. GPIO ctrl only enabled, if <b>Ido3_on</b> = 1 <b>0</b> : No GPIO control <b>1</b> : Controlled by GPIO1 <b>2</b> : Controlled by GPIO2 <b>3</b> : Controlled by GPIO3
3:2	gpio_ctrl_ido2	'b00	RW	Enable GPIO control of LDO2. GPIO ctrl only enabled, if <b>Ido2_on</b> = 1 <b>0</b> : No GPIO control <b>1</b> : Controlled by GPIO1 <b>2</b> : Controlled by GPIO2 <b>3</b> : Controlled by GPIO3
1:0	gpio_ctrl_ido1	'b00	RW	Enable GPIO control of LDO1. GPIO ctrl only enabled, if <b>Ido1_on</b> = 1 <b>0</b> : No GPIO control <b>1</b> : Controlled by GPIO1 <b>2</b> : Controlled by GPIO2 <b>3</b> : Controlled by GPIO3

**GPIOctrl\_Ido2 Register (Address 27h).**

Addr: 27h		GPIOctrl_Ido2		
Bit	Bit Name	Default	Access	Bit Description
7:6	gpio_ctrl_ido8	'b00	RW	Enable GPIO control of LDO8. GPIO ctrl only enabled, if <b>Ido8_on</b> = 1 <b>0</b> : No GPIO control <b>1</b> : Controlled by GPIO1 <b>2</b> : Controlled by GPIO2 <b>3</b> : Controlled by GPIO3
5:4	gpio_ctrl_ido7	'b00	RW	Enable GPIO control of LDO7. GPIO ctrl only enabled, if <b>Ido7_on</b> = 1 <b>0</b> : No GPIO control <b>1</b> : Controlled by GPIO1 <b>2</b> : Controlled by GPIO2 <b>3</b> : Controlled by GPIO3
3:2	gpio_ctrl_ido6	'b00	RW	Enable GPIO control of LDO6. GPIO ctrl only enabled, if <b>Ido6_on</b> = 1 <b>0</b> : No GPIO control <b>1</b> : Controlled by GPIO1 <b>2</b> : Controlled by GPIO2 <b>3</b> : Controlled by GPIO3
1:0	gpio_ctrl_ido5	'b00	RW	Enable GPIO control of LDO5. GPIO ctrl only enabled, if <b>Ido5_on</b> = 1 <b>0</b> : No GPIO control <b>1</b> : Controlled by GPIO1 <b>2</b> : Controlled by GPIO2 <b>3</b> : Controlled by GPIO3

**Reg3\_Voltage Register (Address 2bh).**

Addr: 2bh		Reg3_Voltage		
Bit	Bit Name	Default	Access	Bit Description
7:0	reg3_voltage	'b0000 0000	RW	This register is mapped to the register address 0h+Reg3_select , if gioX_josf=5 or 6 (Vselect input), and GPIOx input = 1, This feature allows voltage switching of a predefined regulator with just one GPIO input <b>0 ..FFh</b> : Selects voltage, ilimit, on or frequency bits of LDO or DCDC

**Reg\_control3 Register (Address 2ch).**

Addr: 2ch		Reg_control3		
Bit	Bit Name	Default	Access	Bit Description
7:4	-	'b0000	n/a	do not use
3:0	reg3_select	'b1111	RW	Selects regulator for mapping feature; if reg_select3 ≥ 0Ch, then feature is disabled.

**SD\_control1 Register (Address 30h).**

Addr: 30h		SD_control1		
Bit	Bit Name	Default	Access	Bit Description
7	sd4_low_noise	0	RW	Enables low noise mode of SD4. If enabled, smaller current pulses and output ripple is activated. <b>0</b> : Normal mode. Minimum current pulses of >100mA applied in skip mode. <b>1</b> : Low noise mode. Only minimum on time applied in skip mode.
6	sd3_low_noise	0	RW	Enables low noise mode of SD3. If enabled, smaller current pulses and output ripple is activated. <b>0</b> : Normal mode. Minimum current pulses of >100mA applied in skip mode. <b>1</b> : Low noise mode. Only minimum on time applied in skip mode.
5	sd2_low_noise	0	RW	Enables low noise mode of SD2. If enabled, smaller current pulses and output ripple is activated. <b>0</b> : Normal mode. Minimum current pulses of >100mA applied in skip mode. <b>1</b> : Low noise mode. Only minimum on time applied in skip mode.
4	sd1_low_noise	0	RW	Enables low noise mode of SD1. If enabled, smaller current pulses and output ripple is activated. <b>0</b> : Normal mode. Minimum current pulses of >100mA applied in skip mode. <b>1</b> : Low noise mode. Only minimum on time applied in skip mode.
3	sd4_fast	0	RW	Selects a faster regulation mode for SD4 suitable for larger load changes. <b>0</b> : normal mode <b>1</b> : fast mode, double Cext required (see external components)
2	sd3_fast	0	RW	Selects a faster regulation mode for SD3 suitable for larger load changes. <b>0</b> : normal mode <b>1</b> : fast mode, double Cext required (see external components)
1	sd2_fast	0	RW	Selects a faster regulation mode for SD2 suitable for larger load changes. <b>0</b> : normal mode <b>1</b> : fast mode, double Cext required (see external components)
0	sd1_fast	0	RW	Selects a faster regulation mode for SD1 suitable for larger load changes. <b>0</b> : normal mode <b>1</b> : fast mode, double Cext required (see external components)



**SD\_control2 Register (Address 31h).**

Addr: 31h		SD_control2		
Bit	Bit Name	Default	Access	Bit Description
7:6	sd_dvm_select	'b00	RW	Apply DVM counter to the following DCDC converter: <b>0</b> : Select SD1 for DVM <b>1</b> : Select SD2 for DVM <b>2</b> : Select SD3 for DVM <b>3</b> : Select SD4 for DVM
5:4	dvm_time	'b00	RW	Time steps of DVM voltage change of selected step down, if voltage of step Down is changed during operation (sd <sub>x</sub> _vsel) voltage is decreased/increased by single steps 12.5mV <b>0</b> : 0 µsec, immediate change (no DVM) <b>1</b> : 4 µsec time delay between steps <b>2</b> : 8 µsec time delay between steps <b>3</b> : 16 µsec time delay between steps
3	sd3_slave	0	RW	Enables slave mode of SD3 <b>0</b> : Normal mode of SD3 <b>1</b> : SD3 is slave of SD2
2	sd3_fsel	0	RW	Selects between high and low frequency range <b>0</b> : 2 or 3MHz frequency (selectable by <b>sd3_frequ</b> ) <b>1</b> : 3 or 4MHz frequency (selectable by <b>sd3_frequ</b> )
1	sd2_fsel	0	RW	Selects between high and low frequency range <b>0</b> : 2 or 3MHz frequency (selectable by <b>sd2_frequ</b> ) <b>1</b> : 3 or 4MHz frequency (selectable by <b>sd2_frequ</b> )
0	sd1_fsel	0	RW	Selects between high and low frequency range <b>0</b> : 2 or 3MHz frequency (selectable by <b>sd1_frequ</b> ) <b>1</b> : 3 or 4MHz frequency (selectable by <b>sd1_frequ</b> )

**Battery\_voltage\_monitor Register (Address 32h).**

Addr: 32h		Battery_voltage_monitor		
Bit	Bit Name	Default	Access	Bit Description
7	FastResEn	0	RW	<b>0</b> : ResVoltFall debounce time = 3msec <b>1</b> : ResVoltFall debounce time = 4μsec
6	SupResEn	0	RW	<b>0</b> : A reset is generated if VSUP falls below 2.7V ** <b>1</b> : A reset is generated if VSUP falls below ResVoltFall ** If VBAT falls below ResVoltFall only an interrupt is generated (if enabled) and the μProcessor can shut down the system)
5:3	ResVoltFall	'b000	RW	This value determines the reset level ResVoltFall for falling VBAT. It is recommended to set this value at least 200mV lower than ResVoltRise <b>0</b> : 2.7V <b>1</b> : 2.9V <b>2</b> : 3.1V <b>3</b> : 3.2V <b>4</b> : 3.3V <b>5</b> : 3.4V <b>6</b> : 3.5V <b>7</b> : 3.6V
2:0	ResVoltRise	'b000	RO (OTP)	This value determines the reset level ResVoltRise for rising VBAT. It is recommended to set this value at least 200mV higher than ResVoltFall <b>0</b> : 2.7V <b>1</b> : 2.9V <b>2</b> : 3.1V <b>3</b> : 3.2V <b>4</b> : 3.3V <b>5</b> : 3.4V <b>6</b> : 3.5V <b>7</b> : 3.6V

**Startup\_Control Register (Address 33h).**

Addr: 33h		Startup_Control		
Bit	Bit Name	Default	Access	Bit Description
7:2	-	'b00 0000	n/a	do not use
0	power_off_at_vsuplow	0	RW	Switch on Power off mode if low VSUP is detected during active or standby mode (Pin ON= low and bit auto_off=0) <b>0</b> : If low battery is detected, battery voltage is continuously monitored and chip startup initiated if battery voltage is above ResVoltRise <b>1</b> : If low battery is detected, enter power off mode

**ResetTimer Register (Address 34h).**

Addr: 34h		ResetTimer		
Bit	Bit Name	Default	Access	Bit Description
7	-	'b0	n/a	do not use
6	stby_reset_disable	0	RW	Disable Reset output signal (pin XRES) in standby mode. 0 : Normal mode, reset is active in standby mode 1 : No reset in standby mode and during exit of standby mode
5	auto_off	0	RO	Defines startup behavior at first battery insertion 0 : Startup of chip if VBAT>ResVoltRise 1 : Enter power off mode (Startup with ON key or charger insertion)
4:3	off_delay	'b01	RW	Set Delay between I2C command, GPIO or Reset signal for power_off, standby mode or reset and execution of that command. 0 : No delay 1 : 8 msec 2 : 16 msec 3 : 32 msec
2	-	'b0	n/a	do not use
1:0	res_timer	'b00	RW	Set RESTime, after the last regulator has started 0 : RESTIME = 10ms 1 : RESTIME = 50ms 2 : RESTIME = 100ms 3 : RESTIME = 150ms

**ReferenceControl Register (Address 35h).**

Addr: 35h		ReferenceControl		
Bit	Bit Name	Default	Access	Bit Description
7	on_reset_delay	0	RW	Sets the on reset delay time <b>0</b> : 8 sec (if <b>onkey_reset=1</b> ) <b>1</b> : 4 sec (if <b>onkey_reset=1</b> )
6	reg_low_bias_mode	0	RW	Sets the on reset delay time <b>0</b> : normal operation <b>1</b> : reduces the bias for the analog LDO1 and LDO2
5	clk_div2	0	RW	Divide internal clock oscillator by 2 to reduce quiescent current for low power operation <b>0</b> : Normal mode <b>1</b> : Internal clock frequency divided by two. All timings are increased by two. Switching frequency of all DCDC converters are divided by two. Reduced transient performance of DCDC converters.
4	standby_mode_on	0	RW	Setting to 1 sets the PMU into standby mode. All regulators are disabled except those regulators enabled by register Reg standby mode. XRES will be pulled to low. A normal startup of all regulators will be done with any interrupt (has to be enabled before entering standby mode). During this startup, regulators defined by Reg standby mode register are continuously on.
3:1	clk_int	'b000	RW	Sets the internal CLK frequency $f_{CLK}$ used for DCDCs, PWM, ... <b>0</b> : 4 MHz (default) <b>1</b> : 3.8 MHz <b>2</b> : 3.6 MHz <b>3</b> : 3.4 MHz <b>4</b> : 3.2 MHz <b>5</b> : 3.0 MHz <b>6</b> : 2.8 MHz <b>7</b> : 2.6 MHz All frequencies, timings and delays in this datasheet are based on 4MHz <b>clk_int</b>
0	low_power_on	0	RW	Enable low power mode of internal reference. <b>0</b> : Standard mode <b>1</b> : Low power mode - all specification except noise parameters are still valid. Iq reduced by approx. 30 $\mu$ A

**ResetControl Register (Address 36h).**

Addr: 36h		ResetControl		
Bit	Bit Name	Default	Access	Bit Description
7	onkey_reset	0	RW	0 : Reset after 4/8 seconds ON pressed disabled 1 : Reset after 4/8 seconds ON pressed enabled
6:3	reset_reason	'b0000	RW	Flags to indicate to the software the reason for the last reset 0 : V <sub>POR</sub> has been reached (battery or charger insertion from scratch) 1 : <b>ResVoltFall</b> was reached (battery voltage drop below 2.75V) 2 : Software forced by <b>force_reset</b> 3 : Software forced by <b>power_off</b> and ON was pulled high 4 : 5 : External triggered through the pin XRES 6 : Reset caused by overtemperature T140 7 : Reset caused by watchdog 8 : Reset caused by 4/8 seconds ON press 9 : NA 10 : Reset caused by RTC repeated wakeup or alarm wakeup 11 : Reset caused by interrupt in standby mode 12 : Reset caused by ON pulled high in standby mode
2	on_input	0	R_PUSH	<b>Read:</b> This flag represents the state of the ON pad directly <b>Write:</b> Setting to 1 resets the 4/8 sec. <b>onkey_reset</b> timer
1	power_off	0	RW	Setting to 1 starts a reset cycle, but waits after the Reg_off state for a rising edge on the pin ON or until the charger is detected.
0	force_reset	0	RW	Setting to 1 starts a complete reset cycle

**OvertemperatureControl Register (Address 37h).**

Addr: 37h		OvertemperatureControl		
Bit	Bit Name	Default	Access	Bit Description
7:4	-	'b0000	n/a	do not use
3	rst_ov_temp_140	0	RW	If the over-temperature threshold 2 has been reached, the flag <b>ov_temp_140</b> is set and a reset cycle is started. <b>ov_temp_140</b> should be reset by writing 1 and afterward 0 to <b>rst_ov_temp_140</b> .
2	ov_temp_140	0	RO	Flag that the over-temperature threshold 2 (T140) has been reached - this flag is not reset by a over-temperature caused reset and has to be reset by <b>rst_ov_temp_140</b> .
1	ov_temp_110	0	RO	Flag that the over-temperature threshold 1 (T110) has been reached
0	temp_pmc_on	1	RO	Switch on / off of temperature supervision; default: on - all other bits are only valid if set to 1. Leave at 1, do not disable

**WatchdogControl Register (Address 38h).**

Addr: 38h		WatchdogControl		
Bit	Bit Name	Default	Access	Bit Description
7:2	-	'b00 0000	n/a	do not use
1	wtdg_res_on	0	RW	If the watchdog expires and wtdg_res_on = 1 a reset cycle will be started
0	wtdg_on	0	RW	Switches on the complete watchdog 0 : Watchdog off 1 : Watchdog enabled

**Reg\_standby\_mod1 Register (Address 39h).**

Addr: 39h		Reg_standby_mod1		
Bit	Bit Name	Default	Access	Bit Description
7	disable_regpd	0	RW	This bit disables the pulldown of all regulators 0 : Normal operation approx. 1k $\Omega$ pulldown of all regulators 1 : Pulldown disabled >100k $\Omega$ of all regulators
6:4	-	b000	n/a	do not use
3	sd4_stby_on	0	RW	Enable Step down 4 in standby mode
2	sd3_stby_on	0	RW	Enable Step down 3 in standby mode
1	sd2_stby_on	0	RW	Enable Step down 2 in standby mode
0	sd1_stby_on	0	RW	Enable Step down 1 in standby mode

**Reg\_standby\_mod2 Register (Address 3ah).**

Addr: 3ah		Reg_standby_mod2		
Bit	Bit Name	Default	Access	Bit Description
7	ldo8_stby_on	0	RW	Enable LDO8 in standby mode
6	ldo7_stby_on	0	RW	Enable LDO7 in standby mode
5	ldo6_stby_on	0	RW	Enable LDO6 in standby mode
4	ldo5_stby_on	0	RW	Enable LDO5 in standby mode
3	ldo4_stby_on	0	RW	Enable LDO4 in standby mode
2	ldo3_stby_on	0	RW	Enable LDO3 in standby mode
1	ldo2_stby_on	0	RW	Enable LDO2 in standby mode
0	ldo1_stby_on	0	RW	Enable LDO1 in standby mode

**curr\_control Register (Address 40h).**

Addr: 40h		curr_control		
Bit	Bit Name	Default	Access	Bit Description
7:4	curr3_ctrl	'b0000	RW	On/Off control of the pad CURRE3 <b>0</b> : Current sink is turned off <b>1</b> : Current sink is active <b>2</b> : Current sink is active and LED string connected to SU2. Required for automatic feedback selection. <b>3</b> : Controlled by internal PWM generator, or external, if gpioX_iosf=4 <b>4</b> : XINT output (active low interrupt output) <b>5</b> : VSUP_low output <b>6</b> : Charger active output <b>7</b> : EOC output <b>8</b> : Inverted signal of ON pin as output <b>9</b> : Signal of ON pin as output <b>10</b> : Q32k output (if osc_pd=1 then internal RC oscillator with 32kHz divider is used) <b>11</b> : PWM output <b>12</b> : PWRGOOD output <b>13-15</b> : NA
3:2	curr2_ctrl	'b00	RW	On/Off control of the pad CURRE2 <b>0</b> : Current sink is turned off <b>1</b> : Current sink is active <b>2</b> : Current sink is active and LED string connected to SU2. Required for automatic feedback selection. <b>3</b> : Controlled by internal PWM generator, or external, if gpioX_iosf=4
1:0	curr1_ctrl	'b00	RW	On/Off control of the pad CURRE1 <b>0</b> : Current sink is turned off <b>1</b> : Current sink is active <b>2</b> : Current sink is active and LED string connected to SU2. Required for automatic feedback selection. <b>3</b> : Controlled by internal PWM generator, or external, if gpioX_iosf=4

**pwm\_control\_l Register (Address 41h).**

Addr: 41h		pwm_control_l		
Bit	Bit Name	Default	Access	Bit Description
7:0	pwm_l_time	'b00000000	RW	This bit defines the low time of the PWM generator in 1MHz units. <b>0</b> : $\text{pwm\_div} * 1\mu\text{sec}$ <b>1</b> : $\text{pwm\_div} * 2\mu\text{sec}$ <b>2</b> : $\text{pwm\_div} * 3\mu\text{sec}$ ... : ... <b>255</b> : $\text{pwm\_div} * 256\mu\text{sec}$

**pwm\_control\_h Register (Address 42h).**

Addr: 42h		pwm_control_h		
Bit	Bit Name	Default	Access	Bit Description
7:0	pwm_h_time	'b00000000	RW	This bit defines the high time of the PWM generator in 1MHz units. <b>0</b> : pwm_div * 1µsec <b>1</b> : pwm_div * 2µsec <b>2</b> : pwm_div * 3µsec ... : ... <b>255</b> : pwm_div * 256µsec

**curr1\_value Register (Address 43h).**

Addr: 43h		curr1_value		
Bit	Bit Name	Default	Access	Bit Description
7:0	curr1_current	'b00000000	RW	Defines the current into CURR1, if enabled by curr1_ctrl <b>0</b> : Power down (default state) <b>1</b> : 0.15mA (LSB) ... : ... <b>255</b> : 38.25mA

**curr2\_value Register (Address 44h).**

Addr: 44h		curr2_value		
Bit	Bit Name	Default	Access	Bit Description
7:0	curr2_current	'b00000000	RW	Defines the current into CURR2, if enabled by curr2_ctrl <b>0</b> : Power down (default state) <b>1</b> : 0.15mA (LSB) ... : ... <b>255</b> : 38.25mA

**curr3\_value Register (Address 45h).**

Addr: 45h		curr3_value		
Bit	Bit Name	Default	Access	Bit Description
7:0	curr3_current	'b00000000	RW	Defines the current into CURR3, if enabled by curr3_ctrl <b>0</b> : Power down (default state) <b>1</b> : 0.15mA (LSB) ... : ... <b>255</b> : 38.25mA



**Watchdog\_min\_timer Register (Address 46h).**

Addr: 46h		Watchdog_min_timer		
Bit	Bit Name	Default	Access	Bit Description
7:0	wtdg_min_timer	'b00000000	RW	Defines the minimum watchdog trigger time (LSB=7.5ms, range: 0 - 1.9s)

**Watchdog\_max\_timer Register (Address 47h).**

Addr: 47h		Watchdog_max_timer		
Bit	Bit Name	Default	Access	Bit Description
7:0	wtdg_max_timer	'b11111111	RW	Defines the maximum watchdog trigger time (LSB=7.5ms, range: 7.5ms - 1.9s), do not set to (00)h

**WatchdogSoftwareSignal Register (Address 48h).**

Addr: 48h		WatchdogSoftwareSignal		
Bit	Bit Name	Default	Access	Bit Description
7:6	pwm_div	'b00	RW	This bit defines the divider ratio of the prescaler for the PWM generator. 0 : Divide by 1 1 : Divide by 2 2 : Divide by 4 3 : Divide by 16
0	wtdg_sw_sig	0	PUSH	Trigger input by the serial interface if gpioX_iosf<>9

**Stepup\_control1 Register (Address 50h).**

Addr: 50h		Stepup_control1		
Bit	Bit Name	Default	Access	Bit Description
7:3	stepup1_v	'b0000	RW	Defines the tuning current at FB_SU1 pin; 0 : 0 $\mu$ A 1 : 1 $\mu$ A ... : ... 31 : 31 $\mu$ A
2	stepup1_res	0	RW	Gain selection for DCDC SU1 0 : If FB_SU1 is used with current feedback only (Only R1,C1 connected) 1 : If FB_SU1 is used with external resistor divider (2 resistors)
1	stepup1_freq	0	RW	Selects SU1 frequency 0 : 1 MHz 1 : 0.5 MHz
0	stepup1_on	0	RW	On/Off control of SU1 0 : SU1 off 1 : SU1 on

**Stepup\_control2 Register (Address 51h).**

Addr: 51h		Stepup_control2		
Bit	Bit Name	Default	Access	Bit Description
7:3	stepup2_v	'b00000	RW	Defines the tuning current at FB_SU2 pin <b>0</b> : 0 $\mu$ A <b>1</b> : 1 $\mu$ A ... : ... <b>31</b> : 31 $\mu$ A
2	stepup2_res	0	RW	Gain selection for DCDC SU2 <b>0</b> : If DCDC is used with current feedback (CURR1,CURR2,CURR3) or if FB_SU2 is used with current feedback only (Only R1,C1 connected) <b>1</b> : If FB_SU2 is used with external resistor divider (2 resistors)
1	stepup2_freq	0	RW	Selects SU3 frequency <b>0</b> : 1 MHz <b>1</b> : 0.5 MHz
0	stepup2_on	0	RW	On/Off control of SU2 <b>0</b> : SU2 off <b>1</b> : SU2 on

**Stepup\_control4 Register (Address 53h).**

Addr: 53h		Stepup_control4		
Bit	Bit Name	Default	Access	Bit Description
7	stpup1_det	0	RO	SU1 detection status register <b>0</b> : VRsense < V <sub>DETECT</sub> for more than 1ms, and DCDC SU1 converter is in pulseskip for more than 1ms. <b>1</b> : VRsense > V <sub>DETECT</sub> for more than 1ms, or the DCDC SU1 converter is not in pulseskip for more than 1ms.
6	stpup1_oc	0	RO	SU1 overcurrent status bit <b>0</b> : VRsense < V <sub>OVCURRENT</sub> <b>1</b> : VRsense > V <sub>OVCURRENT</sub> for more than 5ms (latched state)
5	stpup1_oc_timeout	0	RW	Controls GPIOx switch-off, after overcurrent timeout (5ms) for DCDC SU1 <b>0</b> : Disabled <b>1</b> : Enabled
4	stpup1_shortprot	0	RW	Enables Protection and Detection circuit for DCDC SU1 <b>0</b> : No protection and load detection <b>1</b> : Short protection and load detection enabled
3	stpup2_pwm_lowf	0	RW	Selects PWM operation of SU2 <b>0</b> : High frequency operation PWM>20kHz** <b>1</b> : Low frequency PWM operation: <b>stepup2_on</b> and curr1...3_on (if PWM enabled) switched off during PWM low time ** Step_up switched on all the time. (current sinks are not switched off (currX_on=1 all the time), but currX_current masked to 00h during PWM low time.). During PWM off-time then feedback voltage is sampled.
2	stepup2_prot_dis	0	RW	DCDC SU2 overvoltage protection to prevent damage of external NFET, if CURR1, CURR2 or CURR3 feedback selected, and no LED string connected. <b>0</b> : Switch off DCDC SU2 if the voltage on FB_SU2 exceeds 1.25V <b>1</b> : Overvoltage protection disabled
1:0	stepup2_fb	'b00	RW	Controls the feedback source <b>0</b> : voltage feedback (external resistor divider) selected by <b>stepup2_fbprot</b> <b>1</b> : CURR1 feedback enabled (feedback through white LEDs) <b>2</b> : CURR2 feedback enabled (feedback through white LEDs) <b>3</b> : CURR3 feedback enabled (feedback through white LEDs)

**Stepup\_control5 Register (Address 54h).**

Addr: 54h		Stepup_control5		
Bit	Bit Name	Default	Access	Bit Description
7:4	-	'b0000	n/a	do not use
3	stepup2_pwm_mode	0	RW	Enable PWM mode 0 : Normal operation 1 : PWM mode operation. Feedback is sampled during PWM off-time, if stpup2_lowf=0.
2	stepup12_clkinv	0	RW	Invert input clock of SU1 and SU2 converter 0 : Use positive edge of internal clk 1 : Use negative edge of internal clk
1:0	stepup2_fbprot	'b00	RW	Controls the feedback protection of SU2 with external resistor divider (regulated to 0.8V). 0 : LX_SD4 enabled as input 1 : GPIO2 enabled as input 2 : GPIO3 enabled as input 3 : GPIO4 enabled as input

**RTCcontrol Register (Address 60h).**

Addr: 60h		RTCcontrol		
Bit	Bit Name	Default	Access	Bit Description
7:5	-	'b000	n/a	do not use
4:3	rtc_irq_mode	'b00	RW	0 : Generates an interrupt every second 1 : Generates an interrupt every minute 2 : Generates an interrupt every 2 minute 3 : Generates an interrupt every 8 minute
2	rtc_on	0	RW	Switch on the 32kHz RTC oscillator 0 : 32kHz oscillator disabled 1 : 32kHz oscillator enabled
1	rtc_alarm_wakeup_en	0	RW	0 : Disables RTC alarm wake-up in power off mode 1 : Enable RTC alarm wake-up in power off mode
0	rtc_rep_wakeup_en	0	RW	0 : Disables RTC repeated wake-up in power off mode 1 : Enable RTC repeated wake-up in power off mode

**RTCSecond Register (Address 61h).**

Addr: 61h		RTCSecond		
Bit	Bit Name	Default	Access	Bit Description
7:0	second	00h	RW	-

**RTCMinute1 Register (Address 62h).**

Addr: 62h		RTCMinute1		
Bit	Bit Name	Default	Access	Bit Description
7:0	minute0	00h	RW	-

**RTCMinute2 Register (Address 63h).**

Addr: 63h		RTCMinute2		
Bit	Bit Name	Default	Access	Bit Description
7:0	minute1	00h	RW	-

**RTCMinute3 Register (Address 64h).**

Addr: 64h		RTCMinute3		
Bit	Bit Name	Default	Access	Bit Description
7:0	minute2	00h	RW	-

**RTCAlarmSecond Register (Address 65h).**

Addr: 65h		RTCAlarmSecond		
Bit	Bit Name	Default	Access	Bit Description
7:0	alarmsecond	3Fh	RW	AlarmMinute2 has to be written to latch the whole alarm register

**RTCAlarmMinute Register (Address 66h).**

Addr: 66h		RTCAlarmMinute		
Bit	Bit Name	Default	Access	Bit Description
7:0	alarmminute0	FFh	RW	AlarmMinute2 has to be written to latch the whole alarm register

**RTCAlarmMinute2 Register (Address 67h).**

Addr: 67h		RTCAlarmMinute2		
Bit	Bit Name	Default	Access	Bit Description
7:0	alarmminute1	FFh	RW	AlarmMinute2 has to be written to latch the whole alarm register

**RTCAlarmMinute3 Register (Address 68h).**

Addr: 68h		RTCAlarmMinute3		
Bit	Bit Name	Default	Access	Bit Description
7:0	alarmminute2	FFh	RW	-

**SRAM Register (Address 69h).**

Addr: 69h		SRAM		
Bit	Bit Name	Default	Access	Bit Description
7:0	SRAM	00h	RW	-

**ADC\_control Register (Address 70h).**

Addr: 70h		ADC_control		
Bit	Bit Name	Default	Access	Bit Description
7	start_conversion	0	RW	Writing a 1 into this bit starts one ADC conversion
6	adc_on	0	RW	Writing a 1 into this bit continuously activates the ADC S/H and the input multiplexer. The ADC and the MUX are also activated for a conversion period when <b>start_conversion</b> is set to 1. Useful for high impedance input sources on ADC inputs
5	adc_slow	0	RW	Select ADC sampling frequency <b>0</b> : 250kHz (conversion time: approx. 60µs) <b>1</b> : 62.5kHz (conversion time: approx. 240µs)
4	gpio_lv	0	RW	<b>0</b> : High voltage range of GPIO1...4/SENSEN_SU1 (4:1 divider active) <b>1</b> : Low voltage range of GPIO1...4/SENSEN_SU1 (1:1 divider, 1.8V max)
3:0	adc_select	'b0000	RW	Selects an ADC channel <b>0</b> : ADCIN (1:1) <b>1</b> : Temperature sensor: DIE temperature [C] = adc_result * 0.866 - 274 (1:1) <b>2</b> : XOUT32K (1:1, 1.8Vmax) <b>3</b> : CURR1 (1:1, 1V max) <b>4</b> : CURR2 (1:1, 1V max) <b>5</b> : CURR3 (1:1, 1V max) <b>9</b> : VSUP (4:1) <b>10</b> : SENSEN_SU1 (4:1 or 1:1) <b>11</b> : LX_SD4 (4:1 or 1:1) <b>12</b> : GPIO2 (4:1 or 1:1) <b>13</b> : GPIO3 (4:1 or 1:1) <b>14</b> : GPIO4 (4:1 or 1:1) <b>15</b> : NA

**ADC\_MSB\_result Register (Address 71h).**

Addr: 71h		ADC_MSB_result		
Bit	Bit Name	Default	Access	Bit Description
7	result_not_ready	0	RO	Indicates end of conversion 0 result is ready 1 conversion is running
6:0	D9_3	'b000 0000	RO	ADC result register Bit9..Bit3

**ADC\_LSB\_result Register (Address 72h).**

Addr: 72h		ADC_LSB_result		
Bit	Bit Name	Default	Access	Bit Description
7:3	-	'b0000 0	n/a	do not use
2:0	D2_0	'b000	RO	ADC result register Bit2...Bit0

**RegStatus Register (Address 73h).**

Addr: 73h		RegStatus		
Bit	Bit Name	Default	Access	Bit Description
7	curr3_lv	0	RO	Bit is set when voltage of current sink CURR3 drops below low voltage threshold (1ms debounce time default)
6	curr2_lv	0	RO	Bit is set when voltage of current sink CURR2 drops below low voltage threshold (1ms debounce time default)
5	curr1_lv	0	RO	Bit is set when voltage of current sink CURR1 drops below low voltage threshold (1ms debounce time default)
4	-	0	n/a	do not use
3	sd4_lv	0	RO	Bit is set when voltage of SD4 drops below low voltage threshold (-5%) (1ms debounce time default)
2	sd3_lv	0	RO	Bit is set when voltage of SD3 drops below low voltage threshold (-5%) (1ms debounce time default)
1	sd2_lv	0	RO	Bit is set when voltage of SD2 drops below low voltage threshold (-5%) (1ms debounce time default)
0	sd1_lv	0	RO	Bit is set when voltage of SD1 drops below low voltage threshold (-5%) (1ms debounce time default)

**InterruptMask1 Register (Address 74h).**

Addr: 74h		InterruptMask1		
Bit	Bit Name	Default	Access	Bit Description
7	LowBat_int_m	1	RW	0 : interrupt enabled 1 : interrupt masked (disabled)
6	ovtmp_int_m	1	RW	0 : interrupt enabled 1 : interrupt masked (disabled)
5	onkey_int_m	1	RW	0 : interrupt enabled 1 : interrupt masked (disabled)
4	chdet_int_m	1	RW	0 : interrupt enabled 1 : interrupt masked (disabled)
3	eoc_int_m	1	RW	0 : interrupt enabled 1 : interrupt masked (disabled)
2	resume_int_m	1	RW	0 : interrupt enabled 1 : interrupt masked (disabled)
1	nobat_int_m	1	RW	0 : interrupt enabled 1 : interrupt masked (disabled)
0	trickle_int_m	1	RW	0 : interrupt enabled 1 : interrupt masked (disabled)

**InterruptMask2 Register (Address 75h).**

Addr: 75h		InterruptMask2		
Bit	Bit Name	Default	Access	Bit Description
7	rtc_rep_int_m	1	RW	0 : interrupt enabled 1 : interrupt masked (disabled)
6	stpup1_det_m	1	RW	0 : interrupt enabled 1 : interrupt masked (disabled)
5	stpup1_oc_m	1	RW	0 : interrupt enabled 1 : interrupt masked (disabled)
4	bat_temp_m	1	RW	0 : interrupt enabled 1 : interrupt masked (disabled)
3	sd4_lv_int_m	1	RW	0 : interrupt enabled 1 : interrupt masked (disabled)
2	sd3_lv_int_m	1	RW	0 : interrupt enabled 1 : interrupt masked (disabled)
1	sd2_lv_int_m	1	RW	0 : interrupt enabled 1 : interrupt masked (disabled)
0	sd1_lv_int_m	1	RW	0 : interrupt enabled 1 : interrupt masked (disabled)

**InterruptMask3 Register (Address 76h).**

Addr: 76h		InterruptMask3		
Bit	Bit Name	Default	Access	Bit Description
7:3	-	'b0000 0	n/a	do not use
2	gpio_restart_int_m	1	RW	0 : interrupt enabled 1 : interrupt masked (disabled)
1	gpio_int_m	1	RW	0 : interrupt enabled 1 : interrupt masked (disabled)
0	rtc_alarm_int_m	1	RW	0 : interrupt enabled 1 : interrupt masked (disabled)

**InterruptStatus1 Register (Address 77h).**

Addr: 77h		InterruptStatus1		
Bit	Bit Name	Default	Access	Bit Description
7	LowBat_int_i	0	POP	Bit is set when VsUP drops below <b>ResVoltFall</b>
6	ovtmp_int_i	0	POP	Bit is set when 110deg is exceeded
5	onkey_int_i	0	POP	Rising and falling edge
4	chdet_int_i	0	POP	Rising and falling edge
3	eoc_int_i	0	POP	Rising and falling edge
2	resume_int_i	0	POP	Rising and falling edge
1	nobat_int_i	0	POP	Rising and falling edge
0	trickle_int_i	0	POP	Rising and falling edge



**InterruptStatus2 Register (Address 78h).**

Addr: 78h		InterruptStatus2		
Bit	Bit Name	Default	Access	Bit Description
7	rtc_rep_int_i	0	POP	Rising edge only
6	stpup1_det_i	0	POP	Rising edge only
5	stpup1_oc_i	0	POP	Rising edge only
4	bat_temp_i	0	POP	Rising and falling edge
3	sd4_lv_int_i	0	POP	Rising edge only
2	sd3_lv_int_i	0	POP	Rising edge only
1	sd2_lv_int_i	0	POP	Rising edge only
0	sd1_lv_int_i	0	POP	Rising edge only

**InterruptStatus3 Register (Address 79h).**

Addr: 79h		InterruptStatus3		
Bit	Bit Name	Default	Access	Bit Description
7:3	-	'b0000 0	n/a	do not use
2	gpio_restart_int_i	0	POP	Falling edge
1	gpio_int_i	0	POP	Rising and falling edge
0	rtc_alarm_int_i	0	POP	Rising edge only

**Lock Register (Address 8eh).**

Addr: 8eh		Lock		
Bit	Bit Name	Default	Access	Bit Description
7:3	-	'b0000 0	n/a	do not use
2	-	0	n/a	do not use
1:0	reg_lock	'b00	RW	<p>Enables lock of Regulator voltages Bits can only be set. Reset only with full reset cycle</p> <p><b>0</b> : No lock  <b>1</b> : Lock of voltage of LDOs (LDO1..8_vsel) (all bits) and voltage of StepDownBits(sd1..4_vsel) [5:6] only  <b>2</b> : Lock voltage of StepDownbits 5:6 only (no LDOs)  <b>3</b> : Lock voltage of StepDowns (all bits) and LDOs (all bits).</p> <p><b>Note:</b> Setting sdx_vsel to 0 is possible all the time to allow switching off the regulator. Writing a non-zero value after that will restore the old value.</p>

**ASIC\_ID1 Register (Address 90h).**

Addr: 90h		ASIC_ID1		
Bit	Bit Name	Default	Access	Bit Description
7:0	ID1	8Bh	RO	-

**ASIC\_ID2 Register (Address 91h).**

Addr: 91h		ASIC_ID2		
Bit	Bit Name	Default	Access	Bit Description
3:0	revision	'b0000	RO	<b>Note:</b> Metal fuse!!!

# 11 Application Information

Figure 30. AS3713 Application Schematic

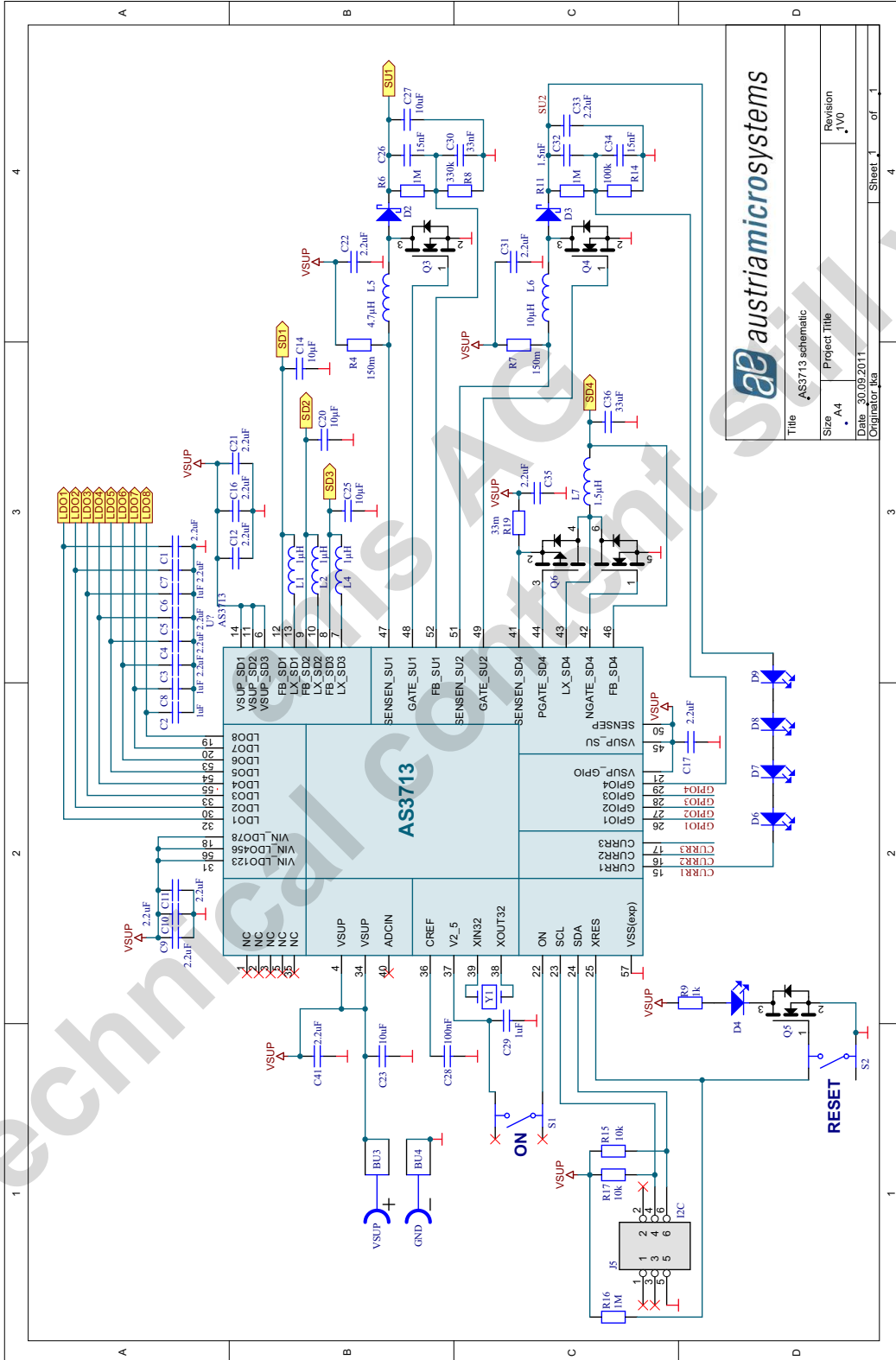

Figure 31. PCB Layout Recommendation for SD1, SD2, SD3 and Switched Mode Charger

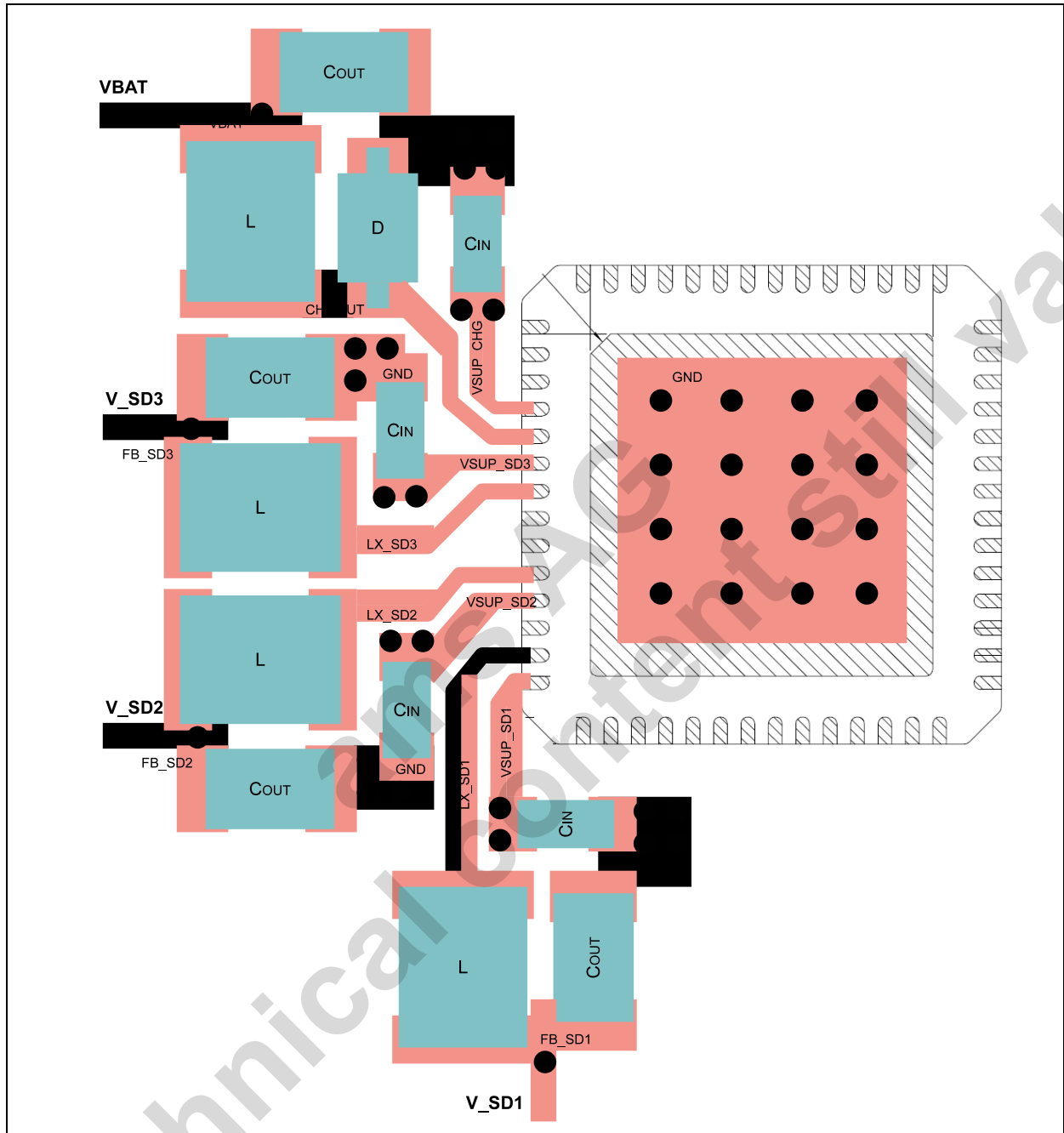
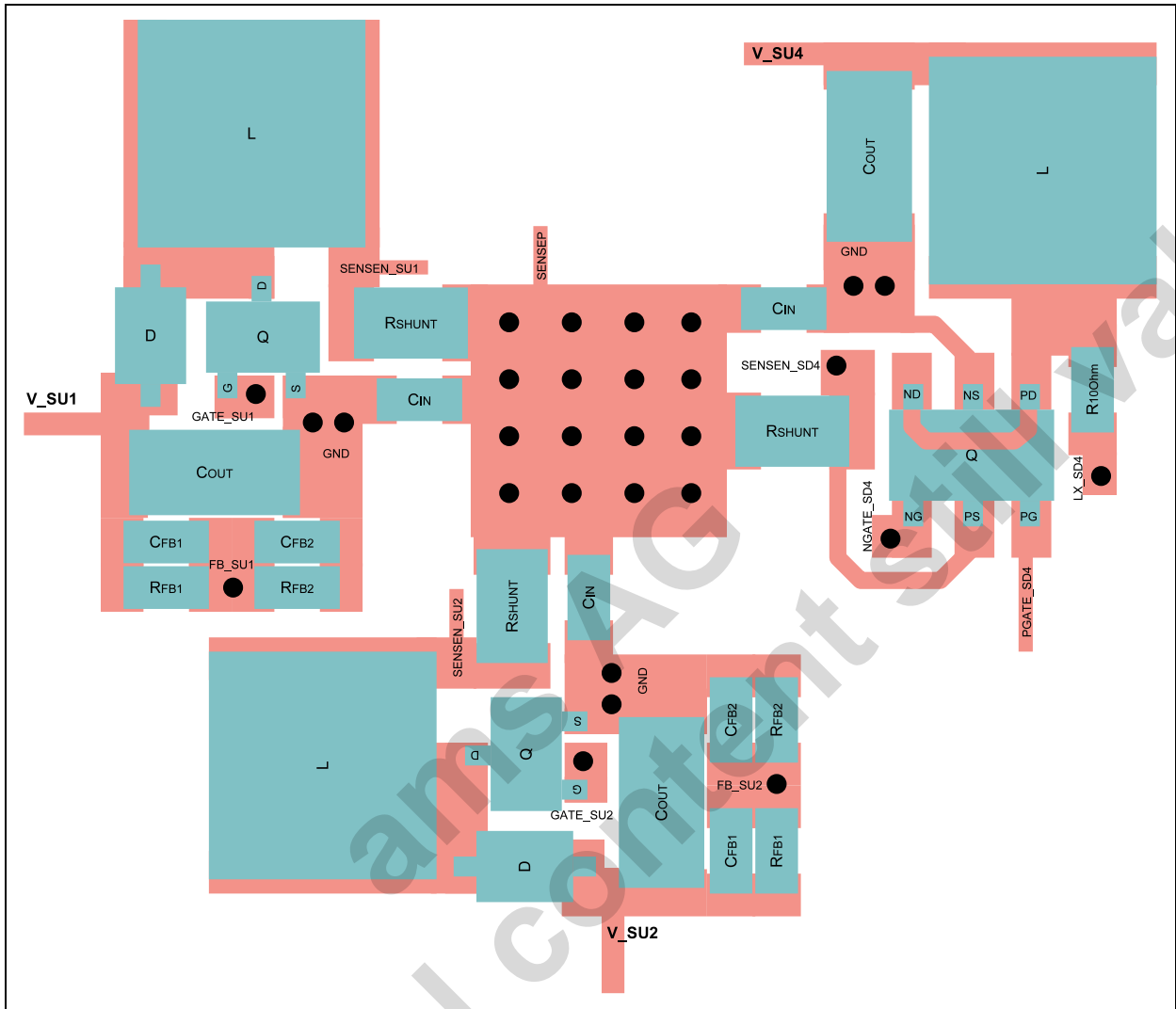
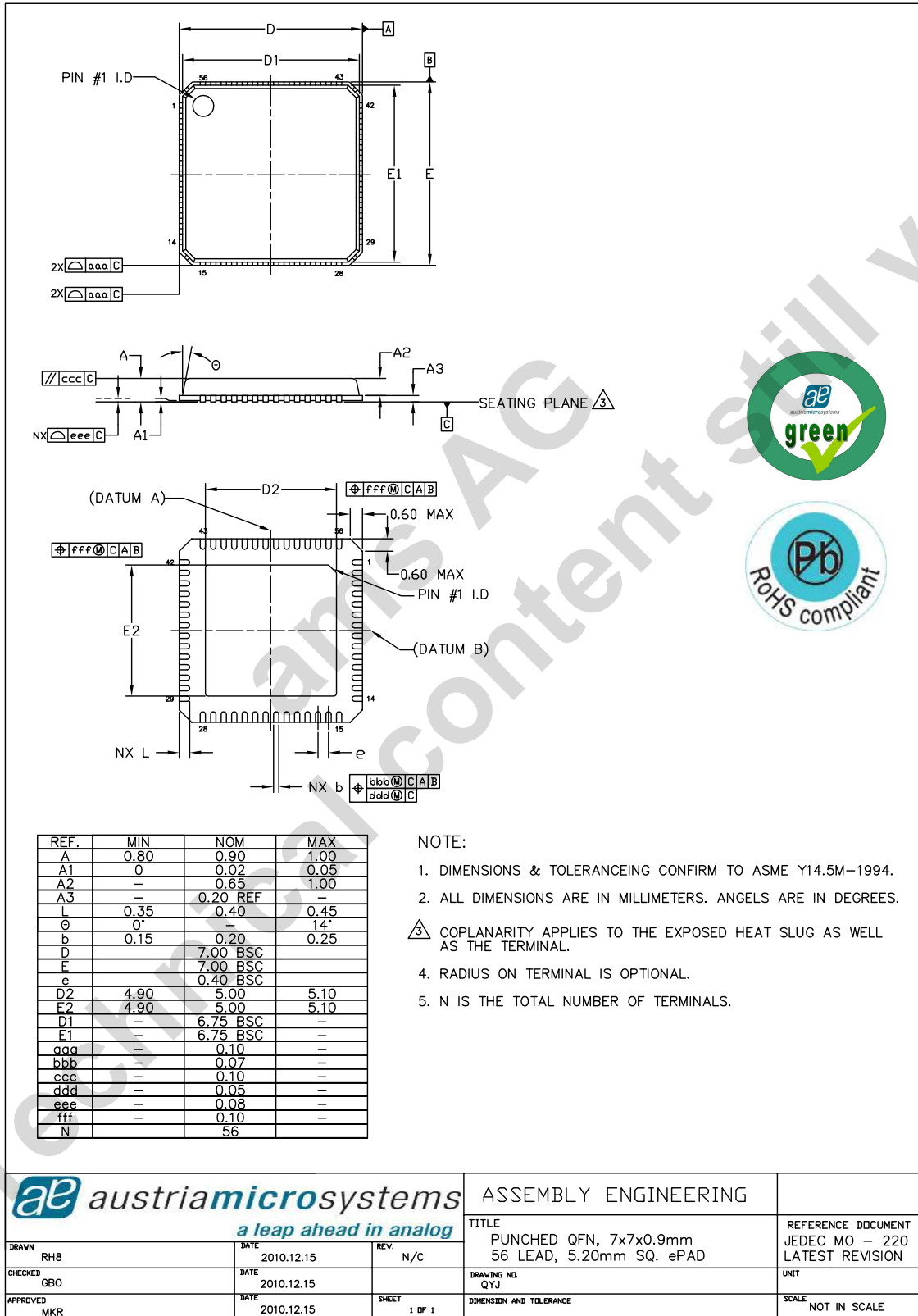

Figure 32. PCB Layout Recommendation for SU1, SU2, SD4



# 12 Package Drawings and Markings

Figure 33. Package Drawings and Dimensions



			ASSEMBLY ENGINEERING	
<i>a leap ahead in analog</i>			TITLE PUNCHED QFN, 7x7x0.9mm 56 LEAD, 5.20mm SQ. ePAD	
DRAWN RHB	DATE 2010.12.15	REV. N/C	REFERENCE DOCUMENT JEDEC MO - 220 LATEST REVISION	
CHECKED GBO	DATE 2010.12.15		DRAWING NO. QYJ	UNIT
APPROVED MKR	DATE 2010.12.15	SHEET 1 OF 1	DIMENSION AND TOLERANCE	SCALE NOT IN SCALE

Figure 34. QFN Marking

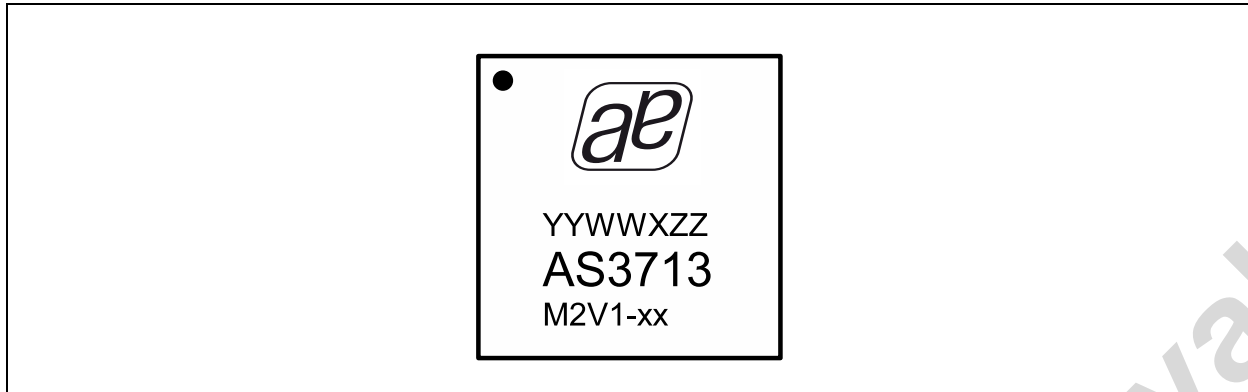

Table 31. Package Code YWWZZZ

YY	WW	X	ZZ
year	working week assembly / packaging	plant identifier	free choice

Table 32. Start-up Revision Code

xx	Sequence
FF	engineering samples, no sequence programmed or sequence programmed on request
00	default sequence (no sequence programmed)
xx	customer specified sequence programmed during production test

## Revision History

Revision	Date	Owner	Description
0.10	3.2011	pkm	Initial draft
0.20	10.2011	pkm, cwo	typo corrections; updated block diagrams, PCB layout recommendations, charger mode diagrams, application schematics, DCDC performance characteristics added register 2bh and 2ch for chip version 2v1.
1.0	10.2011	pkm	first official release
1.1	12.2011	pkm	corrected ntc_on bit description, adjusted max die temperature, updated dc/dc mode description
1.2	5.2012	pkm	corrected "enter standby mode", GPIO1 input mode description, GPIO block diagram, GPIO IOSF, interrupt signal polarity added switching charger graphs, added step-up external components, ASIC ID

**Note:** Typos may not be explicitly mentioned under revision history.



## 13 Ordering Information

The devices are available as the standard products shown below.

Table 33. Ordering Information

Ordering Code	Marking	Sequence	Description	Delivery Form	Package
AS3713-BQFR-FF	M2V1-FF	sequence programmable on request	Quad Buck High Current PMIC without Charger	Tray	QFN56 7x7 0.4mm pitch
AS3713-BQFP-00	M2V1-00	default sequence	Quad Buck High Current PMIC without Charger	Tape & Reel dry pack	QFN56 7x7 0.4mm pitch
AS3713-BQFP-xx	M2V1-xx	customer specified	Quad Buck High Current PMIC without Charger	Tape & Reel dry pack	QFN56 7x7 0.4mm pitch

**Note:** All products are RoHS compliant and austriamicrosystems green.

Buy our products or get free samples online at ICdirect: <http://www.austriamicrosystems.com/ICdirect>

Technical Support is available at <http://www.austriamicrosystems.com/Technical-Support>

For further information and requests, please contact us [mailto: sales@austriamicrosystems.com](mailto:sales@austriamicrosystems.com) or find your local distributor at <http://www.austriamicrosystems.com/distributor>

## Copyrights

Copyright © 1997-2012, austriamicrosystems AG, Tobelbaderstrasse 30, 8141 Unterpremstaetten, Austria-Europe. Trademarks Registered ®. All rights reserved. The material herein may not be reproduced, adapted, merged, translated, stored, or used without the prior written consent of the copyright owner.

All products and companies mentioned are trademarks or registered trademarks of their respective companies.

## Disclaimer

Devices sold by austriamicrosystems AG are covered by the warranty and patent indemnification provisions appearing in its Term of Sale. austriamicrosystems AG makes no warranty, express, statutory, implied, or by description regarding the information set forth herein or regarding the freedom of the described devices from patent infringement. austriamicrosystems AG reserves the right to change specifications and prices at any time and without notice. Therefore, prior to designing this product into a system, it is necessary to check with austriamicrosystems AG for current information. This product is intended for use in normal commercial applications. Applications requiring extended temperature range, unusual environmental requirements, or high reliability applications, such as military, medical life-support or life-sustaining equipment are specifically not recommended without additional processing by austriamicrosystems AG for each application. For shipments of less than 100 parts the manufacturing flow might show deviations from the standard production flow, such as test flow or test location.

The information furnished here by austriamicrosystems AG is believed to be correct and accurate. However, austriamicrosystems AG shall not be liable to recipient or any third party for any damages, including but not limited to personal injury, property damage, loss of profits, loss of use, interruption of business or indirect, special, incidental or consequential damages, of any kind, in connection with or arising out of the furnishing, performance or use of the technical data herein. No obligation or liability to recipient or any third party shall arise or flow out of austriamicrosystems AG rendering of technical or other services.



## Contact Information

### Headquarters

austriamicrosystems AG  
Tobelbaderstrasse 30  
A-8141 Unterpremstaetten, Austria

Tel: +43 (0) 3136 500 0  
Fax: +43 (0) 3136 525 01

For Sales Offices, Distributors and Representatives, please visit:

<http://www.austriamicrosystems.com/contact>