

PART NUMBER	REV	FIRST USED
680120-1	A	854400-1
680120-2	A	565435-5
680120-3	A	354500-1

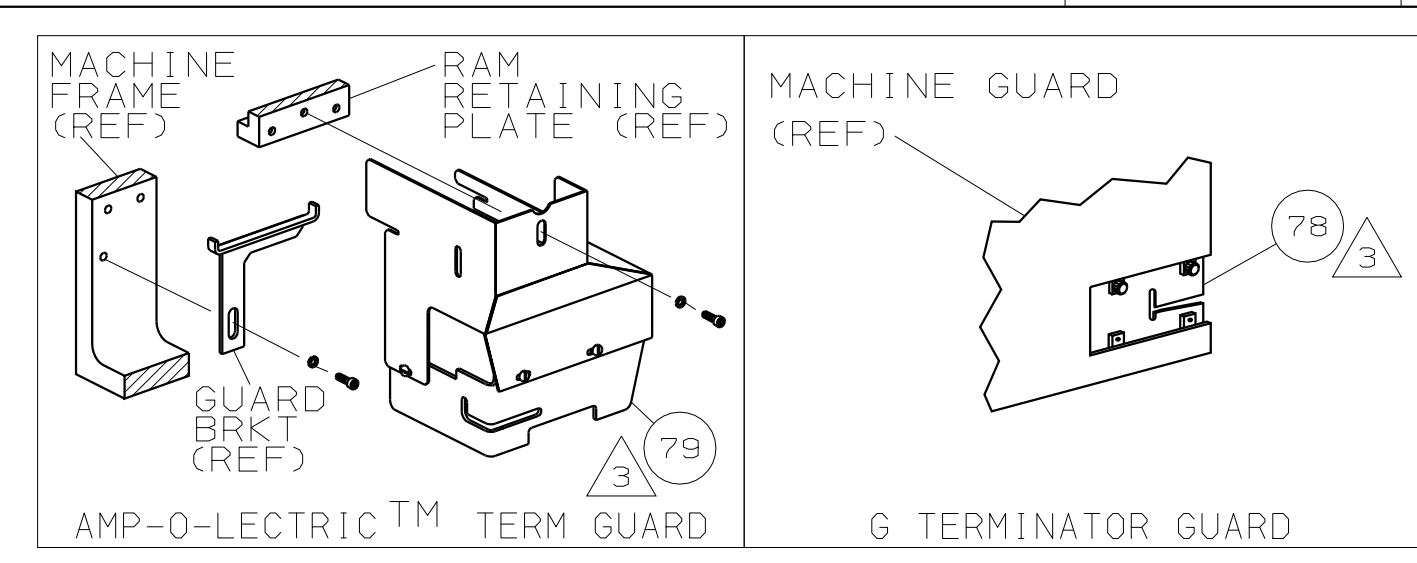

TERMINAL NAME:		CRIMPING DATA	
TAB MIC MK II			
	281937-1	PAD LTR	CRIMP HEIGHT
		A	.058 ±.002
		B	.053 ±.002 (2)0.5 OR (1) 1mm <sup>2</sup>
		C	.046 ±.002
		D	NOT USED
		CRIMP	SIZE TYPE RANGE
		WIRE	.090 F 0.5 - 1.5 mm <sup>2</sup>
		INSUL	.120 F ø1.5-2.4 MM
		FEED	APPL INST SET UP GAGE LAYOUT
		1.181	408-8039 458638-1 L1592
		TERM APPL SPEC 114-2004B	WIRE STRIP LENGTH -

-1	LEADMAKER	AIRFEED							
-2	BENCH MODEL K	AIRFEED							
-3	BENCH MODEL G	AIRFEED							
-	1	-	-	C	692655-5	AIR FEED VALVE ASSY			70
-	REF	-	-	A	24042-2	VALVE, SHUT OFF			67
-	REF	-	-	C	692655-6	AIR FEED VALVE ASSY			66
1	1	1	-	B	1-460277-5	AIR FEED ASSY			65
2	2	2	-	A	3-21000-9	SCR,SHC(10-32x1.00)AIR ASSY			64
1	-	1	-	A	22294-6	ELBOW, TUBING 1/8NPT - 1/4 T			63
1	-	1	-	A	23238-1	QUICK DISCONNECT			62
12.00	12.00	12.00	IN	A	27319-4	TUBING, POLY-FLO ø.25			61
									60
1	1	1	-	C	454220-1	CAP, RAM			59
1	1	1	-	D	453736-1	HOUSING			58
									57
									56
									55
									54
1	1	1	-	B	460680-1	FEED FINGER ASSY			53
									52
									51
									50
									49
									48
									47
									46
1	1	1	-	A	690191-1	PLUG, NYLON			45
1	1	1	-	C	455674-1	RAM			44
1	1	1	-	A	690125-1	WASHER, LAMINATED			43
1	1	1	-	A	690124-1	WASHER, RAM			42
1	1	1	-	A	7-21002-9	BOLT, CRIMPER(5/16-24x1.00)			41
1	1	1	-	A	23241-6	BALL, STEEL			40
1	1	1	-	A	690170-1	SPRING, COMPRESSION			39
1	1	1	-	C	690142-1	DISC, INSULATION			38
1	1	1	-	D	354777-1	WIRE DISC, PLASTIC			37
1	1	1	-	A	22480-5	WASHER, SPRING			36
1	1	1	-	B	690212-1	POST, RAM			35
									34
									33
									32
									31
									30
									29
1	1	1	-	B	1-690451-8	SPACER, STRIPPER			28
1	1	1	-	A	240639-3	STRIPPER			27
1	1	1	-	D	455676-1	PLATE, BASE			26
2	2	2	-	A	22354-8	DRAG, STUD			25
1	1	1	-	B	458803-9	PLATE, STRIP GUIDE			24
1	1	1	-	C	240825-2	PLATE, STRIP HOLD DOWN			23
2	2	2	-	A	4-22281-1	SPRING, DRAG			22
									21
1	1	1	-	A	454177-1	DRAG, STOCK			20
									19
2	2	2	-	C	454204-6	GUIDE, STRIP (FRONT)			18
									17
									16
									15
1	1	1	-	C	690481-3	SPACER, HOLD DOWN			14
1	1	1	-	C	1-690481-0	SPACER, HOLD DOWN			13
1	1	1	-	A	23846-1	SPRING, HOLD DOWN			12
1	1	1	-	B	240833-7	PLATE, REAR SHEAR			11
2	2	2	-	C	1-240645-6	SPACER, SHEAR PLATE			10
1	1	1	-	B	240642-1	PLATE, FRONT SHEAR			9
1	1	1	-	D	8-683452-3	ANVIL			8
1	1	1	-	B	240651-7	BLADE, SLUG			7
1	1	1	-	D	1-455892-8	HOLD DOWN, TERMINAL			6
1	1	1	-	C	7-240641-0	SPACER, SLUG BLADE			5
1	1	1	-	B	1-238009-2	SPACER, BLOCK CRIMPER			4
1	1	1	-	C	5-456134-1	CRIMPER, INSULATION			3
1	1	1	-	C	1-455888-0	SPACER, CRIMPER			2
1	1	1	-	C	1-456420-0	CRIMPER, WIRE			1

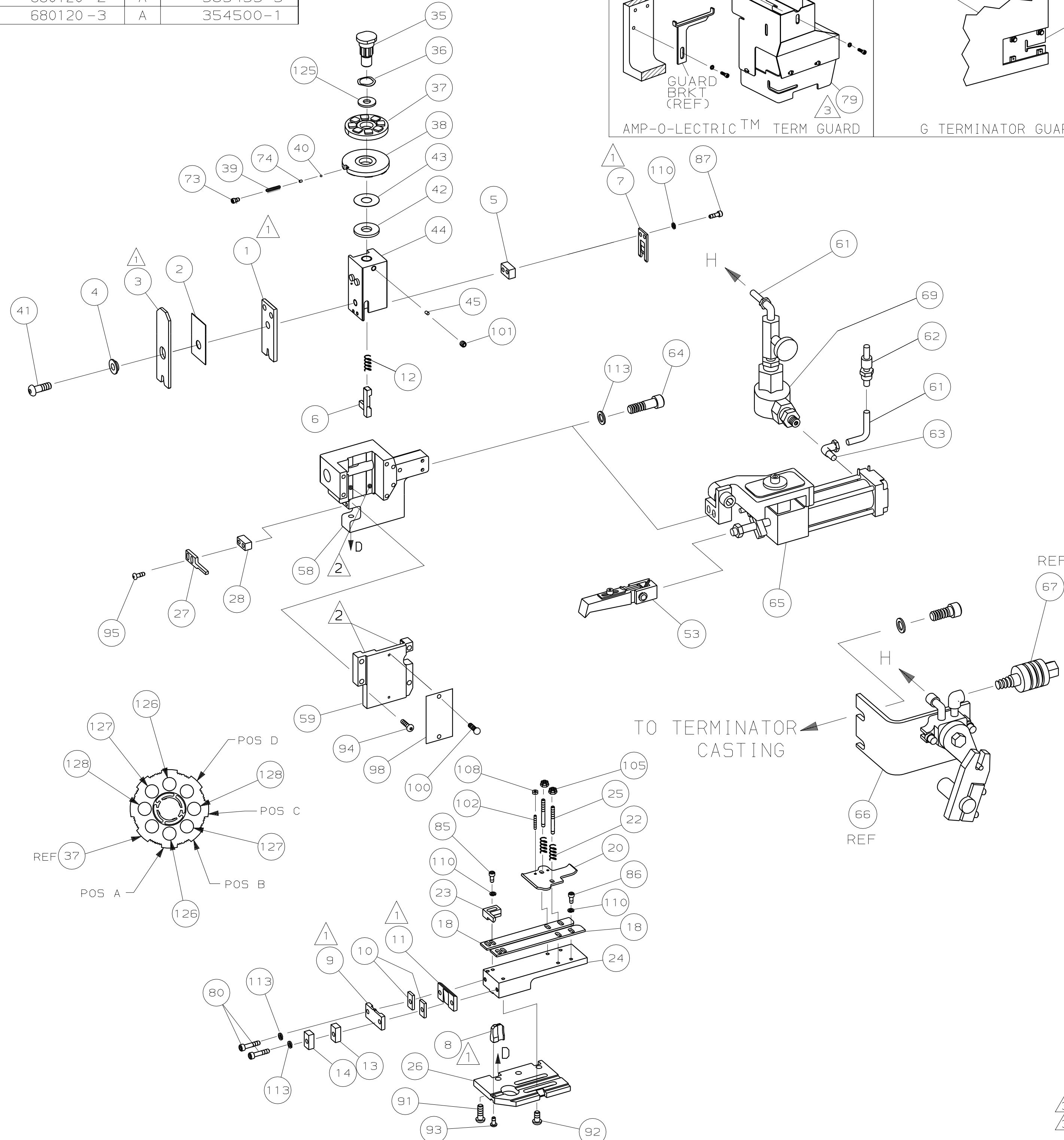

- ① RECOMMENDED SPARE PARTS.
- ② GREASE LIGHTLY.
- ③ GUARD MUST BE IN PLACE WHEN OPERATING APPLICATOR IN A BENCH MACHINE.
- ④ SEE DRAWING FOR COMPONENTS

2	2	2	-	C	3-354779-0	PIN, WIRE DISC (.3140)C	129
2	2	2	-	C	1-354779-6	PIN, WIRE DISC (.3070)B	128
2	2	2	-	C	354779-6	PIN, WIRE DISC (.3020)A	126
1	1	1	-	A	986950-1	WASHER, FLAT PRECISION	125
							124
							123
							122
							121
							120
							119
							118
							117
							116
							115
							114
4	4	4	-	A	21024-5	WASHER, LOCK (NO.10) SHEAR PL	113
							112
							111
7	7	7	-	A	21024-4	WASHER, LOCK (NO.8) SHEAR BL	110
							109
2	2	2	-	A	21018-4	NUT, HEX (4-40) DRAG	108
							107
							106
2	2	2	-	A	21022-2	NUT, HEX SL (8-32) DRAG STUD	105
							104
							103
2	2	2	-	A	4-21078-8	SKT SKT SET (4-40x.75) DRAG	102
1	1	1	-	A	21009-2	SCR, SKT SET (1/4-20x.25) RAM	101
2	2	2	-	A	21017-2	SCR, DRIVE (#2x.19) ID PLATE	100
							99
1	1	1	-	B	461264-1	PLATE, IDENTIFICATION	98
							97
							96
2	2	2	-	A	2-21002-2	SCR, BHC (8-32x.50) STRIPPER	95
4	4	4	-	A	2-21002-9	SCR, BHC (10-32x.75) CAP	94
1	1	1	-	A	22733-8	SCR, BHC (8-32x.38 LW) ANVIL	93
4	4	4	-	A	3-21002-3	SCR, BHC (1/4-20x.50) ST GD PL	92
3	3	3	-	A	2-22733-8	SCR, BHC (1/4-20x.62) H5G	91
							90
							89
							88
2	2	2	-	A	3-21000-0	SCR, SHC (8-32x.88) SLUG BLADE	87
3	3	3	-	A	2-21000-5	SCR, SHC (8-32x.25) STRIP GUIDE	86
2	2	2	-	A	2-21000-8	SCR, SHC (8-32x.62) R STRIP GUIDE	85
							84
							83
							82
							81
2	2	2	-	A	3-21000-8	SCR, SKT CAP (10-32x.88) SH PL	80
-	1	-	-	A	455750-8	GUARD ASSY	79
REF	-	-	-	A	679532-1	INSERT, GUARD	78
							77
							76
							75
1	1	1	-	A	690603-1	SPRING, ASSIST	74
1	1	1	-	A	23030-1	SCR, SKT CAP (6-32x.25) CP DSC	73
							72
							71

QTY	REQD	PER	ASSY	U/M	DWG	SIZE	PART NO	DESCRIPTION	ITEM
									NO
REVISION OF EACH ASSY NO (WHEN BLANK, USE DWG REVISION)									
PARTS LIST									

QTY	REQD	PER	ASSY	U/M	DWG	SIZE	PART NO	DESCRIPTION	ITEM
									NO
REVISION OF EACH ASSY NO (WHEN BLANK, USE DWG REVISION)									
PARTS LIST									

LOC A  
DIST 66

DIMENSIONS IN INCHES. DO NOT SCALE PRINT. TOLERANCES UNLESS OTHERWISE SPECIFIED:  
 2 PLC DEC ±.25  
 3 PLC DEC ±.125  
 4 PLC DEC ±.0625  
 ANGLES ± -  
 SURF TEXTURE: ✓  
 REMOVE BURRS, BREAK SHARP EDGES R.015 MAX

MATL - HT TR - FIN -

DR 7/25/94 APP 7-25-94  
 P.MATHIAS T.ELBIN  
 CHK 7-25-94 REL 11/3/94  
 C.ERISMAN B. MORGAN

**AMP** AMP Incorporated Harrisburg, PA 17105-3608

NAME END FEED HDM APPLICATOR MACHINE REF MINI APPL  
 SCALE - DWG NO 680120 SHEET 1 OF 1 REV A

THIS DRAWING IS A CONTROLLED DOCUMENT FOR AMP INCORPORATED. IT IS SUBJECT TO CHANGE AND THE CONTROLLING ENGINEERING ORGANIZATION SHOULD BE CONTACTED FOR THE LATEST REVISION.

THIS INFORMATION IS CONFIDENTIAL AND IS DISCLOSED TO YOU ON CONDITION THAT NO FURTHER DISCLOSURE IS MADE BY YOU TO OTHER THAN AMP PERSONNEL WITHOUT WRITTEN AUTHORIZATION FROM AMP INCORPORATED, HARRISBURG, PA.

680120

D

C

B

A